

# Motion Sensor II

## CI-6742A

Included Equipment	Part Number
Motion Sensor II	CI-6742A
Additional Equipment Required	
<i>ScienceWorkshop</i> Interface	CI-7650, CI-6400, or similar

## Introduction

The Motion Sensor II works with your *ScienceWorkshop* interface and DataStudio software to measure and record motion data. It produces a series of ultrasonic pulses and detects the sound reflecting back from an object in front of it. The interface measures the times between outgoing pulses and returning echoes. From these measurements, DataStudio determines the position, velocity, and acceleration of the object.

This instruction sheet includes procedures for:

- setting up the hardware and software (page 2),
- collecting data (page 2),
- changing the sample rate (page 2),
- calibrating the sensor (page 2),
- mounting the sensor on equipment (page 3), and
- troubleshooting (page 3).

Theory of operation is described on page 3, and specifications are listed on page 4.

*Note: Essential DataStudio tasks are described briefly in this instruction sheet. For more instructions on using DataStudio, press F1 to open DataStudio's on-line help.*

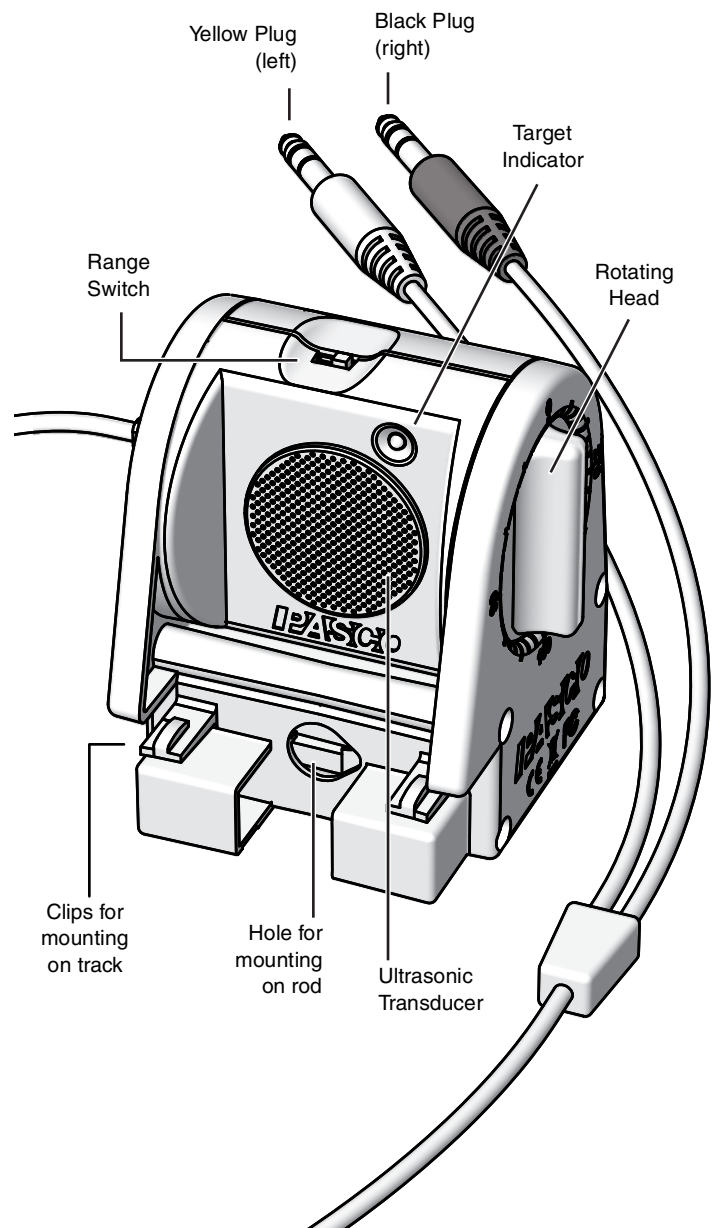

## Set-up

### To Connect to a *ScienceWorkshop* Interface





Connect the Motion Sensor's yellow plug to Digital Channel 1 of your *ScienceWorkshop* interface. Connect the black plug to Digital Channel 2.

If you are using a 700 or 750 interface, you can also connect the yellow and black plugs to channels 2 and 3, or channels 3 and 4. The plugs must be adjacent to each other with the yellow plug on the left. To use two Motion Sensors simultaneously, connect one sensor to channels 1 and 2 and connect the other to channels 3 and 4.

### To Configure DataStudio

1. Launch DataStudio and start a new activity.
2. On the picture of the interface in the Experiment Setup window, click the digital channel that the Motion Sensor's yellow plug is connect to. A sensor list opens.
3. In the sensors list, click **Motion Sensor** and click **OK**.
4. Double-click the **Graph** icon (or other display icon) to create a data display for position, velocity, or acceleration.

### To Aim the Motion Sensor at an Object

1. Set the range switch to short range (  ) or long range (  ) setting.
  - Select  for measuring a cart on a track.
  - Select  for measuring most other objects.
2. Arrange the Motion Sensor and object so that the Motion Sensor's transducer faces the object.
  - The object should be at least 15 cm from the transducer.
  - If the object will move, it should move directly toward or away from the Motion Sensor.
  - Aim the motion sensor slightly up to avoid detecting the tabletop.

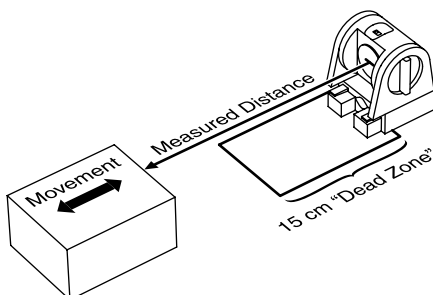

3. Remove objects that may interfere with the measurement. These include objects between the sensor and target object, either directly in front of the sensor or to the sides.

## Data Collection

### To Record Data

1. In DataStudio, click **Start**.

The Motion Sensor starts clicking. If a target is in range, the target indicator flashes with each click. DataStudio starts collecting and displaying data.

2. Click **Stop** to stop data collection.
3. Click **Start** again to start recording data in a new data run.

### To Display Data without Recording

From the Experiment menu, select **Monitor**. The Motion Sensor starts clicking and DataStudio displays live data.

## Sensor Configuration

### To Change the Sample Rate

In the Experiment Setup window, click the up or down button next to the **Sample Rate** setting.

The normal range of sampling rates is between 1 Hz and 50 Hz. At the default rate of 10 Hz, the Motion Sensor can measure distance up to 8 m. The maximum distance decreases with increasing sample rate. At very high sample rates (between 50 Hz and 250 Hz), the maximum distance is less than 2 m.

### To Calibrate the Motion Sensor

1. In the Experiment Setup window, click the Motion Sensor tab.
2. Place a target object at a standard distance in front of the Motion Sensor (typically about 1 m).
3. Precisely measure the distance from the Motion Sensor's transducer to the nearest point of the target object.
4. Enter this distance (in meters) in the **Standard Distance** field.
5. Click the **Set Sensor Distance = Standard Distance** button.

DataStudio adjusts the speed-of-sound constant that it uses to calculate distance.

## Equipment Mounting

Mount the Motion Sensor as illustrated on a vertical rod (a) or a horizontal rod (b).

Integrated clips allow it to be attached to the end of a dynamics track (c).

A threaded hole in the bottom of the unit (d) is provided for attachment to the PS-2546 Magnetic Bracket (e), the ME-6743 Cart Adapter (f), and other 1/4-20 threaded mounting devices such as a camera tripod.

To protect the Motion Sensor from being hit by an object, use a device such as the SE-7256 Motion Sensor Guard (g) or ME-9806 bracket with a rubber band (h). The Motion Sensor can “see through” a wire screen or rubber band placed close to the transducer.

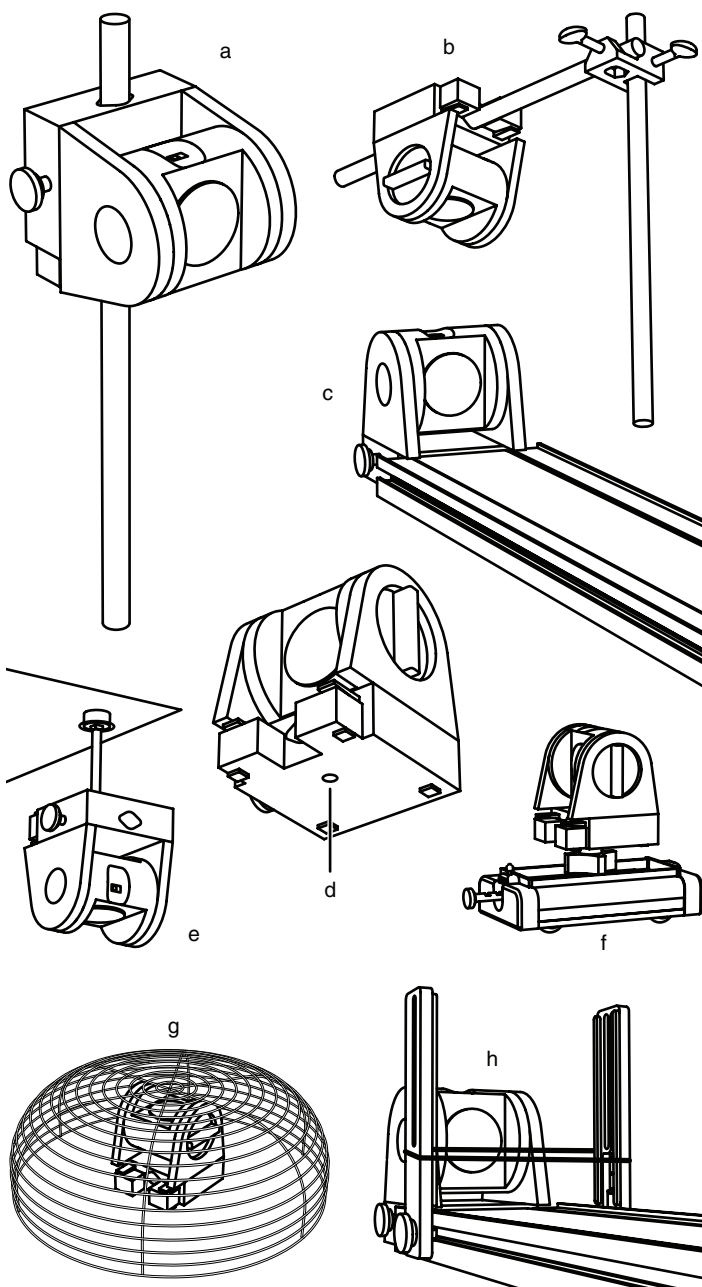

## Troubleshooting

If the Motion Sensor fails to perform satisfactorily, try these steps:

- Ensure that the target object is no closer than 15 cm.
- Switch the range switch to the other setting.
- Adjust the aim left, right, up, or down. In some cases the Motion Sensor works best when it is aimed slightly to the side or above the target in order to exclude interfering objects.
- Improve the target by adding a larger or harder surface to reflect ultrasound. A small object can be a better reflector than large object if it has a harder surface.
- Remove interfering objects near the target object or sensor.
- Increase or decrease the sample rate.

## Theory of Operation

The Motion Sensor uses an electrostatic transducer as both a speaker and a microphone. When triggered by the *ScienceWorkshop* interface, the transducer transmits a burst of 16 ultrasonic pulses with a frequency of about 49 kHz. This burst of pulses can be heard as a single click. The ultrasonic pulses reflect off an object and return to the sensor. The target indicator on the sensor flashes when transducer detects an echo.

Sound intensity decreases with distance; to compensate, the sensor increases the gain of the receiver amplifier as it waits for the echo. The increased gain allows the sensor to detect an object up to 8 m away. The lower gain at the beginning of the cycle reduces the circuit's sensitivity to echoes from false targets.

The *ScienceWorkshop* interface measures the time between trigger rising edge and the echo rising edge. DataStudio uses this time and the speed of sound to calculate the distance to the object. To determine velocity, DataStudio uses consecutive position measurements to calculate the rate of change of position. Similarly, it determines acceleration using consecutive velocity measurements.

## Specifications

<b>Minimum Range</b>	15 cm
<b>Maximum Range</b>	8 m
<b>Transducer Rotation</b>	360°
<b>Range Settings</b>	<p><b>Short Range:</b> for distance measurement up to 2 m with improved rejection of false target signals and air-track noise</p> <p><b>Long Range:</b> for distance measurement up to 8 m</p>
<b>Mounting Options</b>	<ul style="list-style-type: none"> <li>• On rod up to 12.7 mm diameter</li> <li>• Directly to PASCO dynamics tracks</li> <li>• On table top</li> </ul>
<b>Connector</b>	Dual stereo phone plug for <i>ScienceWorkshop</i> interfaces

## Technical Support

For assistance with any PASCO product, contact PASCO at:

Address: PASCO scientific  
10101 Foothills Blvd.  
Roseville, CA 95747-7100

Phone: 916-786-3800 (worldwide)  
800-772-8700 (U.S.)

Fax: (916) 786-7565

Web: [www.pasco.com](http://www.pasco.com)

Email: [support@pasco.com](mailto:support@pasco.com)

**Limited Warranty** For a description of the product warranty, see the PASCO catalog.

**Copyright** The PASCO scientific 012-09624A *Motion Sensor II Instruction Sheet* is copyrighted with all rights reserved. Permission is granted to non-profit educational institutions for reproduction of any part of this manual, providing the reproductions are used only in their laboratories and classrooms, and are not sold for profit. Reproduction under any other circumstances, without the written consent of PASCO scientific, is prohibited.

**Trademarks** PASCO, PASCO scientific, DataStudio, and ScienceWorkshop are trademarks or registered trademarks of PASCO scientific, in the United States and/or in other countries. All other brands, products, or service names are or may be trademarks or service marks of, and are used to identify, products or services of, their respective owners. For more information visit [www.pasco.com/legal](http://www.pasco.com/legal).