

Science Workshop[®]

Earth Science Labs with Computers

Teacher's Guide

Earth Science experiments using the *Science Workshop*[®] or *DataStudio*[™] program and interfaces from PASCO scientific[®]

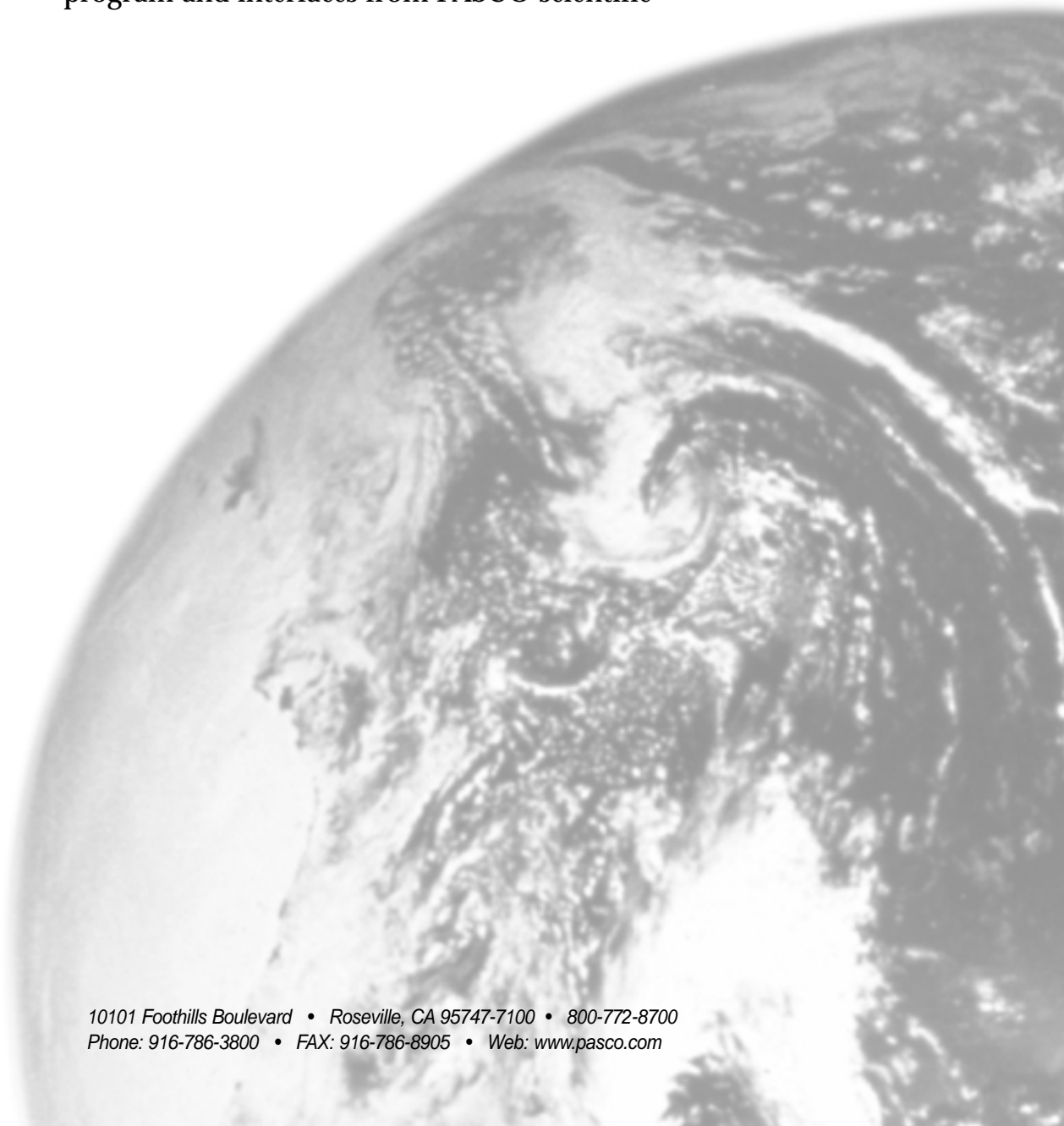

Copyright Information

Earth Science Labs with Computers: Teacher's Guide is copyrighted 1999 by **PASCO scientific** and all rights reserved. Permission is granted to non-profit educational institutions for reproduction of any part of this book providing the reproductions are used only for their laboratories and are not sold for profit. Reproductions under any other circumstances without the written consent of **PASCO scientific** is prohibited except in the case of brief quotations embodied in critical articles or reviews.

Macintosh® is a registered trademark of Apple Computers Incorporated. Windows™ is a trademark of Microsoft Corporation. *DataStudio*™ and *ScienceWorkshop*® are trademarks of **PASCO scientific**.

Published by

PASCO scientific

10101 Foothills Boulevard

Roseville, CA 95747-7100

Phone: (916) 786-3800

FAX (916) 786-8905

Earth Science Labs with Computers: Teacher's Guide

PASCO Catalog Number CI-7060A.

PASCO Part Number 012-06651B.

Printed in the United States of America.

ISBN 1-886998-12-4

Cover designed by Dayna Wergedal.

Authors: David Griffith and Diana Marshall

Table of Contents

Activities List	iii
Preface	v
Correlation with <u>National Science Education Standards</u> (1996)	ix
Equipment List by Activity	xiii
Preparation Information Summary	xxix
 Instructions – Using the Interface and <i>DataStudio</i>	
Quick Reference Guide for <i>DataStudio</i>	A – 1
<i>Section 1: ScienceWorkshop 500 Interface</i>	A – 3
<i>Section 2: Experiment Setup - DataStudio</i>	A – 4
<i>Section 3: Data Analysis – DataStudio</i>	A – 7
 Instructions – Using <i>ScienceWorkshop</i>	
Quick Reference Guide for <i>ScienceWorkshop</i>	A – 9
<i>Section 1: Experiment Setup</i>	A – 11
<i>Section 2: Data Analysis</i>	A – 14
 Tutorial Activities – Exploration of the Sensors	
Light Sensor	A – 17
Motion Sensor	A – 19
pH Sensor	A – 22
Pressure Sensor	A – 24
Temperature Sensor	A – 26

Teacher's Guide Activities List — Part 1

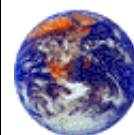

Stewardship:
The Water Planet

Memorandum — About Stewardship: The Water Planet	1
S01 Streams and Rivers	5
Lab Report	9
Teacher's Notes	15
S02 Measure Stream Flow (<i>Flow Rate Sensor</i>)	17
Lab Report	21
Teacher's Notes	23
S03 Temperature of Flowing Water (<i>Temperature Sensor</i>)	25
Lab Report	29
Teacher's Notes	31
S04 Clarity and Turbidity in Water (<i>Light Sensor</i>)	33
Lab Report	39
Teacher's Notes	41
S05 Reducing Turbidity in Water (<i>Light Sensor</i>)	43
Lab Report	47
Teacher's Notes	49
S06 pH of a Natural Water System (<i>pH Sensor</i>)	51
Lab Report	55
Teacher's Notes	57
S07 Acid Rain: Detection and Causes (<i>pH Sensor</i>)	59
Lab Report	65
Teacher's Notes	67
Appendix A — Procedure Details for Part 1: <i>Stewardship – The Water Planet</i>	69 – 92

Teacher's Guide Activities List — Part 2

Memorandum — Mission to Other Worlds	93
M01 Design and Construct a Model Rocket.....	97
Lab Report.....	101
Teacher's Notes.....	103
M02 Acceleration of a Model Rocket (Motion Sensor)	105
Lab Report.....	111
Teacher's Notes.....	113
M03 Determine a Space Craft Surface – Heat Transfer (Temperature Sensor)	117
Lab Report.....	121
Teacher's Notes.....	123
M04 Map a Planetary Surface (Motion Sensor).....	125
Lab Report.....	129
Teacher's Notes.....	131
M05 Acceleration of a Falling Object (Motion Sensor)	133
Lab Report.....	137
Teacher's Notes.....	139
M06 Design Landing Bags (Pressure Sensor - Absolute)	141
Lab Report.....	147
Teacher's Notes.....	149
M07 Temperature at Different Locations (Temperature Sensor).....	151
Lab Report.....	155
Teacher's Notes.....	157
M08 Relative Humidity (Temperature Sensors).....	159
Lab Report.....	165
Teacher's Notes.....	169
M09 pH of Samples from Other Worlds (pH Sensor)	171
Lab Report	175
Teacher's Notes.....	177
M10 Test for Life: Measure a Chemical Reaction (Pressure Sensor - Absolute).....	179
Lab Report.....	185
Teacher's Notes.....	187
Appendix B — Technical Manual for Part 2: <i>Mission to Other Worlds</i>	189 – 222

Appendix – Data LoggingAppendix C — Data Logging with the *ScienceWorkshop* 500 Interface

C01 Installing Batteries.....	223
C02 Disconnect for Logging.....	225
C03 Data Recording.....	227
C04 Reconnect to Download and Analyze Data	229

Preface

I. Overview of Earth Science Labs with Computers: Student Workbook (CI-7061A)

The Student Workbook for Earth Science Labs with Computers has seventeen activities in two independent parts. Each part is based on a theme related to popular concepts in earth science:

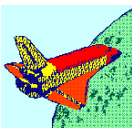
Part	Theme	Description
1	 <p>Stewardship: The Water Planet</p>	<p>This part has two components:</p> <ol style="list-style-type: none"> 1. On a field trip to a stream, river, pond, or other source of water, students will use <i>DataStudio</i> or <i>ScienceWorkshop</i> to make measurements of flow rate and temperature. They will also collect water samples that will be tested in the lab for turbidity, clarity, and pH using <i>ScienceWorkshop</i>. 2. In the lab, students will use <i>DataStudio</i> or <i>ScienceWorkshop</i> to explore the relationships between the quality of water and factors that affect it (e.g., organisms, pollutants, etc.). <p>Students will use their understanding of these relationships to do the following:</p> <ul style="list-style-type: none"> • Discuss some of the causes and possible consequences of poor water quality. • Propose ways to protect and/or improve water quality.
Part	Theme	Description
2	 <p>Mission to Other Worlds</p>	<p>This part is based on the following scenario:</p> <p>Students are members of a Space Agency science research team. They are given tasks related to a planned future mission to another planet.</p> <p>They will use <i>DataStudio</i> or <i>ScienceWorkshop</i> in activities designed to emulate the following:</p> <ul style="list-style-type: none"> • sending a spacecraft to another world • exploration of a planetary surface <p>Based on their results, students will make recommendations to the project manager (instructor) about such things as the best landing site, how much acceleration a spacecraft might experience on landing, etc.</p>

Teamwork

Each activity allows students to work as a team to creatively solve a problem or answer a question related to a concept from earth science. While solving the problem or finding the answer, students will be challenged to do the following: devise a plan, construct experimental setups, use *DataStudio* or *ScienceWorkshop* to record and analyze data, and report results

Extensions

All of the activities can lead to further exploration of the topics in earth science.

Student Workbook Components — Part 1

Each activity in Part 1 of the Student Workbook has two parts:

Procedure Outline

The Procedure Outline is a *basic outline* of how to get started and it has four sections:

- A. Set up the equipment
- B. Set up the experiment
- C. Do the experiment
- D. Analyze the data

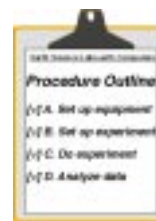

The Procedure Outline has general instructions about how to set up equipment and use *DataStudio* or *ScienceWorkshop* to record and analyze data.

Report

The report asks the students to do the following:

- Restate the purpose of the activity in their own words
- Record their results and write their conclusions
- Answer the questions and write definitions for the vocabulary words in the Procedure Outline

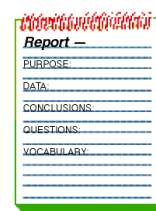

In addition, each activity in Part 1 has a matching section in Appendix A

Appendix A

Appendix A of the Student Workbook has ‘Procedure Details’ for each activity in Part 1. The ‘Procedure Details’ section gives *step-by-step* instructions of how to plug in sensors, set up equipment, and use *DataStudio* or *ScienceWorkshop* to record data and analyze results.



Student Workbook Components — Part 2

Each activity in Part 2 of the Student Workbook has three parts:

Memorandum

The first part of each activity in Part 2 is a “memo” from a fictional character who works at a Space Agency. In the memo, students are given a specific task (or job) and background about the task. They will also receive the following:

- General description of a procedure
- Recommended equipment
- List of expected outcomes

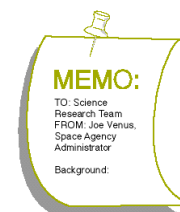

Procedure Outline and Report

The second and third parts of each activity in Part 2 are the same as the *Procedure Outline* and *Report* in Part 1.

In addition, each activity in Part 2 has a matching section in Appendix B.

Appendix B

Appendix B of the Student Workbook has a ‘Technical Manual’ section for each activity in Part 2. The Technical Manual gives *step-by-step* instructions.

II. Overview of Earth Science Labs with Computers: Teacher's Guide (CI-7060A)

The Teacher's Guide includes all of the pages of the **Student Workbook** (including the appendices) plus the following additions:

- **Correlation** of each activity with the National Science Education Content and Teaching Standards.
- **Equipment List** for each activity including quantities where appropriate.
- **Preparation Information Summary.**
- Full description of the components of the Student Workbook and the Earth Science Bundle.
- Completed **Lab Report** with typical data, answers to questions, and vocabulary definitions. If students are challenged to make conclusions, suggestions, or recommendations, typical answers are included.
- **Teacher's Notes** including time estimates for preparation and the lab, student objectives, safety reminders, tips and techniques, and suggested Extensions for the activities.



III. Overview of the Earth Science Bundle

Earth Science Bundle

The PASCO Earth Science Bundle includes the following:

- *ScienceWorkshop 500* Interface
- Sensors
- Earth Science Labs with Computers, Student Workbook
- Earth Science Labs with Computers, Teacher's Guide
- Storage container

Earth Science Bundle Sensors:

Sensor Name	Sensor Part Number
Light Sensor	CI-6504A
Temperature Sensor	CI-6505A
pH Sensor	CI-6507A
Motion Sensor	CI-6742
Pressure Sensor - Absolute	CI-6532A

IV. Safety Reminders

PASCO scientific assumes no responsibility or liability for use of the equipment, materials, or descriptions in this book.

- Take safety precautions to protect yourself during all activities in the lab, and especially during the lab activities in this manual.
- It is not possible to include every safety precaution or warning! Please use extra care when setting up and using the equipment.
- Be sure to wear protective gear such as goggles or safety glasses to protect your eyes and face.
- Be careful around open flames and when using a hot plate.
- Use tongs when handling anything hot. Before touching something that you think might be hot, place the back of your hand near the object to sensor its temperature.
- If you have a question, please ask for help.

A list of 'Safety Reminders' similar to the following is included in each activity in the Student Workbook.

SAFETY REMINDERS

- Wear protective gear while handling chemicals.
- Follow directions for using the equipment.
- Dispose of all chemicals and solutions properly.



For more information about usage, storage, and disposal of chemicals, refer to the Flinn Scientific Catalog. You can contact Flinn Scientific at:

P.O. Box 219
131 Flinn Street
Batavia, IL 60510

Phone: (708) 879-6962 or (800) 452-1261 toll-free in the U.S.A.
E-mail: flinnsci@aol.com

V. Acknowledgements

The editor thanks all of the people who helped in writing, revising or editing the activities in this manual.

November 1, 1999.

Standards Cross-Reference

The Standards Cross-Reference shows how the activities in Earth Science Labs with Computers address standards described in National Science Education Standards, National Academy Press, copyright 1996.

Description of the *Standards*

The *Standards* consist of six groups: Science Teacher, Science Content, Professional Development, Science Education Programs, Assessment, and Science Education System.

Each group contains several standards. Each standard is supported by a list of actions, underlying abilities, and concepts. A description of the actions, abilities, and concepts is part of each standard.

Description of *Earth Science Labs with Computers*

Earth Science Labs with Computers has seventeen activities presented in two parts: *Stewardship — The Water Planet*, and *Mission to Other Worlds*. Fifteen of the seventeen activities are designed so that students use sensors, an interface, and a computer to record and analyze data.

Each activity addresses one or more standards. For example, every one of the seventeen activities is an opportunity for students to collaborate (*Teaching Standard E: Develop Communities of Science Learners, Nurture Collaboration Among Students*). Specifically, the ten activities in *Mission to Other Worlds* are designed so that each student plays a role as a member of a science research team working for a space agency (*Science Content Standard E: Science and Technology, Understanding About Science and Technology*).

The *Standards* and *Earth Science Labs with Computers*

What parts of the *Standards* are addressed by the activities in Earth Science Labs with Computers? Here is one example.

The *Science Content Standards* are divided into eight categories: Unifying Concepts and Process, Science as Inquiry, Physical Science, Life Science, Earth and Space Science, Science and Technology, Science in Personal and Social Perspectives, and History and Nature of Science.

Each category in the *Science Content Standard* has its own list of standards supported by underlying abilities and concepts. The *Unifying Concepts and Processes* standard is presented for all grade levels and the other standards are clustered for grade levels K – 4, 5 – 8, and 9 – 12.

One example of a standard that is addressed by every activity is the *Unifying Concepts and Processes Standard*.

SCIENCE CONTENT STANDARD: Unifying Concepts and Processes

As a result of activities in grades K-12, all students should develop understanding and abilities aligned with the following concepts and processes:

- Systems, order, and organization
- Evidence, models, and explanation
- Constancy, change, and measurement
- Evolution and equilibrium
- Form and function

Fifteen of the seventeen activities are designed so that students use sensors, an interface, and a computer to record and analyze data. These activities address the following *Standard*:

SCIENCE CONTENT STANDARD A: Science as Inquiry

As a result of (their activities), all students should develop

- Abilities necessary to do scientific inquiry

The following table lists each cluster, an underlying ability for the first part of the standard, and part of the description of the underlying ability:

Cluster	Underlying ability	Description
K-4	Employ simple equipment and tools to gather data and extend the senses.	Children also develop skills in the use of computers and calculators for conducting investigations.
5-8	Use appropriate tools and techniques to gather, analyze, and interpret data.	The use of computers for the collection, summary, and display of evidence is part of this standard. Students should be able to access, gather, store, retrieve, and organize data, using hardware and software designed for these purposes.
9-12	Use technology and mathematics to improve investigations and communications.	The use of computers for the collection, analysis, and display of data is also a part of this standard.

SCIENCE CONTENT STANDARD A: Science as Inquiry

As a result of (their activities), all students should develop

- Abilities necessary to do scientific inquiry

The following table lists each cluster and a description:

Cluster	Description
K-4	Scientists develop explanations using observations (evidence) and what they already know about the world (scientific knowledge). Good explanations are based on evidence from observations.
5-8	Technology used to gather data enhances accuracy and allows scientists to analyze and quantify results of investigations.
9-12	Scientists rely on technology to enhance the gathering and manipulation of data. The accuracy and precision of the data, and therefore the quality of the exploration, depends on the technology used.

The next table lists standards from the National Science Education Standards and the titles of corresponding activities.

Table: Activity Titles and National Science Education Standards

No.	Title	Cluster	Standard and Description
All	All	All	<i>Teaching Standard A:</i> Teachers of science plan an inquiry-based science program for their students.
All	All	All	<i>Teaching Standard B:</i> Teachers of science guide and facilitate learning. In doing this, teachers focus and support inquiries while interacting with students.
All	All	All	<i>Teaching Standard D:</i> Teachers of science make the available science tools, materials, media, and technological resources available to students.
All	All	All	<i>Teaching Standard E:</i> Teachers of science develop communities of science learners that reflect the intellectual rigor of scientific inquiry and the attitudes and social values conducive to science learning. In doing this, teachers nurture collaboration among students.
All	All	All	<i>Content Standard K-12: Unifying Concepts & Processes,</i> <ul style="list-style-type: none"> Evidence, Models, and Investigations.
All	All	All	<i>Content Standard A: Science as Inquiry</i> <ul style="list-style-type: none"> Abilities necessary to do scientific inquiry Understanding about scientific inquiry
M03	Determine a Spacecraft Surface - Heat Transfer	5-8	<i>Concept Standard B: Physical Science, Transfer of Energy</i> <ul style="list-style-type: none"> Energy is transferred in many ways.
M10	Test for Life - Measure a Chemical Reaction	9-12	<i>Concept Standard B: Physical Science, Chemical Reactions</i> <ul style="list-style-type: none"> Chemical reactions in living systems are catalyzed by protein molecules called enzymes.
S04	Clarity and Turbidity in Water	5-8	<i>Concept Standard C: Life Science, Populations and Ecosystem</i> <ul style="list-style-type: none"> For ecosystems, the major source of energy is sunlight.
M10	Test for Life - Measure a Chemical Reaction	9-12	<i>Concept Standard C: Life Science, The Cell</i> <ul style="list-style-type: none"> Most cell functions involve chemical reactions.
S06	pH of a Natural Water System	5-8	<i>Content Standard D: Earth and Space Science, Structure of the Earth System</i> <ul style="list-style-type: none"> Water is a solvent. As it passes through the water cycle it dissolves minerals and gases and carries them to the oceans.
S07	Acid Rain: Causes and Detection	5-8	<i>Content Standard D: Earth and Space Science, Structure of the Earth System</i> <ul style="list-style-type: none"> Living organisms have played many roles in the earth system, including affecting the composition of the atmosphere.
M05	Acceleration of a Falling Object	5-8	<i>Content Standard D: Earth and Space Science, Earth in the Solar System</i> <ul style="list-style-type: none"> Gravity alone holds us to the earth's surface...

No.	Title	Cluster	Standard and Description
M07	Temperature at Remote Locations	9-12	<p><i>Content Standard D: Earth and Space Science, Energy in the Earth System</i></p> <ul style="list-style-type: none"> Global climate is determined by energy transfer from the sun at and near the earth's surface. This energy transfer is influenced by dynamic processes such as cloud cover and the earth's rotation, and static conditions such as the position of mountain ranges and oceans.
All	All	K-4, 5-8	<p><i>Content Standard E: Science and Technology, Understandings about Science and Technology</i></p> <ul style="list-style-type: none"> Scientists and engineers often work in teams with different individuals doing different things that contribute to the results. Science and technology are reciprocal
M01	Design and Construct a Model Rocket	K-4, 5-8	<p><i>Content Standard E: Science and Technology, Abilities of Technological Design</i></p> <ul style="list-style-type: none"> Propose a solution. Implement a proposed design.
M02	Acceleration of a Model Rocket	5-8, 9-12	<p><i>Content Standard E: Science and Technology, Abilities of Technological Design</i></p> <ul style="list-style-type: none"> Implement a proposed design.
S07	Acid Rain: Causes and Detection	K-4, 5-8, 9-12	<p><i>Content Standard F: Science in Personal and Social Perspectives, Changes in Environments, Environmental Quality</i></p> <ul style="list-style-type: none"> Changes in environments can be natural or influenced by humans. Human activities also can induce hazards through resource acquisition, urban growth, land-use decisions, and waste disposal. Humans are changing many...basic processes, and the changes may be detrimental to humans.
All	All	K-4, 5-8, 9-12	<p><i>Content Standard G: History and Nature of Science, Science as a Human Endeavor</i></p> <ul style="list-style-type: none"> Science and technology have been practiced by people for a long time. Science will never be finished. Many people derive great pleasure from doing science. Science requires different abilities, depending on such factors as the field of study and type of inquiry. Individuals and teams have contributed and will continue to contribute to the scientific enterprise.
All	All	5-8, 9-12	<p><i>Content Standard G: History and Nature of Science, Nature of Science, Nature of Scientific Knowledge</i></p> <ul style="list-style-type: none"> Scientists formulate and test their explanations of nature using observation, experiments, and theoretical and mathematical models. Scientific explanations must meet certain criteria. First and foremost, they must be consistent with experimental and observational evidence about nature...

Equipment List

Boldface type indicates items available from PASCO scientific. *Italics* type indicates optional items. "PS" means "per student".

<p>Earth Science Labs with Computers Equipment List, Part 1</p>	 <p>Stewardship: The Water Planet</p>
--	---

No.	Title	Equipment & Consumables	Qty.	Cat. #
S01	Streams and Rivers	bucket, ~8 liter	1	
		container, ~2 liter	1	
		funnel	1	
		meter stick	1	
		protractor	1	
		stream table	1	
		tubing, -----	30 cm	
		sand	10 kg	
		water -----	10 L	
		<i>clay</i> <i>grass clippings</i> <i>pebbles</i> <i>potting soil</i> <i>sticks</i>		
S02	Measure Stream Flow	Flow Rate Sensor	1	CI-6730 SE-8712A
		Metric Measuring Tape -----	1	
		waterproof tape -----	1 roll	
		personal flotation device (PS)	1	
		waders or rubber boots (PS)	1 pair	
S03	Temperature of Flowing Water	Temperature Sensor	1	CI-6505A SE-8712A
		Metric Measuring Tape	1	
		marker pen	1	
		pole (approximately 2 m)	1	
		rubber band	2	
		sensor cable (from CI-6504A) -----	1	
		personal flotation device (PS)	1	
		waders or rubber boots (PS)	1 pair	

Earth Science Labs with Computers Equipment List, Part 1 (continued)

No.	Title	Equipment & Consumables	Qty.	Cat. #
S04	Clarity and Turbidity in Flowing Water	Light Sensor	1	CI-6504A
		Base & Support Rod	1	ME-9355
		beaker, 1000 mL	2	
		bottle, square, clear, ~125 mL	1	
		Clamp, Buret	2	SE-9446
		Clamp, Multi	1	SE-9442
		container	1	
		graduated cylinder	2	
		light source, DC (e.g., pen light)	1	
		marker pen	1	
		Rod, Lab Stand	1	ME-8736
		Secchi disk symbol	1	

		personal flotation device (PS)	1	
		waders or rubber boots (PS)	1 pair	

		cardboard box, 15 by 15 by 12 cm	1	
<i>dirt (optional)</i>	100 g			
label	1			
tape	1 roll			
water	2 L			
S05	Reducing Turbidity in Water	Light Sensor	1	CI-6504A
		Balance, Triple Beam	1	SE-8723
		Base & Support Rod	1	ME-9355
		bottle, square, clear, ~500 mL	3	
		Clamp, Buret	2	SE-9446
		Clamp, Multi	1	SE-9442
		container, ~3 liter	1	
		graduated cylinder, 100 mL	1	
		light source, DC (e.g., pen light)	1	
		knife	1	
		marker pen	1	
		Rod, Lab Stand	1	ME-8736

		personal flotation device (PS)	1	
		waders or rubber boots (PS)	1 pair	

		aluminum sulfate (Al ₂ (SO ₄) ₃)	5 g	
calcium oxide (CaO),	2.5 g			
iron (II) chloride (FeCl ₂)	2.5 g			
cardboard box, 15 by 15 by 12 cm	1			
label	3			
muddy water	3 L			
weighing paper	3			

Earth Science Labs with Computers Equipment List, Part 1 (continued)

No.	Title	Equipment & Consumables	Qty.	Cat. #
S06	pH of Rivers and Streams	pH Sensor	1	CI-6507A
		beaker, 250 mL	3	
		bottle, ~500 mL	5	
		marker pen	1 ea	
		wash bottle	1 L	
		water sampling pole with container	1	

		personal flotation device (PS)	1	
		waders or rubber boots (PS)	1 pair	
		protective gear (PS)	1 set	

buffer solution: high pH	100 mL			
buffer solution: low pH	100 mL			
distilled water	1 L			
S07	Acid Rain: Detection and Causes	pH Sensor	1	CI-6507A
		Base & Support Rod	1	
		beaker, 250 mL	3	ME-9355
		beaker, 100 mL	4	
		Beral-type pipette, 15 cm stem	3	
		Beral-type pipette, 2 cm stem	3	
		Beral-type pipette with 1 molar HCl	1	
		Clamp, Buret	1	
		test tube, 20 by 150 mm	1	
		wash bottle	1	

		protective gear (PS)	1 set	

		buffer solution: high pH	100 mL	SE-9446
		buffer solution: low pH	100 mL	
		distilled water	1 L	
		sodium hydrogen carbonate (NaHCO ₃), solid	5 g	
sodium hydrogen sulfite (NaHSO ₃), solid	5 g			
sodium nitrite (NaNO ₂), solid	5 g			
tap water	12 mL			

Earth Science Labs with Computers Equipment List, Part 2

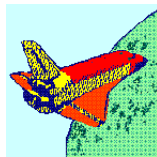

Mission to Other Worlds

No.	Title	Equipment & Consumables	Qty.	Cat. #
M01	Design and Construct a Rocket	cardboard sheets, 21 by 28 cm cardboard tube, approx. 60 cm glue newspaper, sheet plastic sheet, thin, ~30 by 30 cm plastic soda bottle, ~2 liter string tape ----- pencil or pen ruler or straight-edge scissors <i>hot glue gun</i> <i>paint</i> <i>paint brush or sprayer</i>	1 or 2 1 1 tube several 1 1 4 m 1 roll 1 1 1 pair	
M02	Acceleration of a Model Rocket	Per Class Motion Sensor air pump (e.g., bicycle tire pump) Base & Support Rod dowel or stick model rocket launcher tire pressure gauge Per Team container, 2 liter model rocket Per Student safety goggles ----- cardboard sheet tape water	1 1 1 3 1 1 1 1 1 pair 1 1 roll 3 L	CI-6742 ME-9355
M03	Determine a Space Craft Surface: Heat Transfer	Temperature Sensor Aluminum Can, Black Aluminum Can, Shiny graduated cylinder heat lamp ruler or metric tape thermal insulation pad ----- protective gear (PS) ----- water	2 1 1 1 1 1 1 2 1 set 1 L	CI-6505A TD-8570A TD-8570A
M04	Map a Planetary Surface	Motion Sensor object (e.g., chair, table, book) <i>tape measure (optional)</i>	1 4-5 1	CI-6742

Earth Science Labs with Computers Equipment List, Part 2 (continued)

No.	Title	Equipment & Consumables	Qty.	Cat. #
M05	Acceleration of a Falling Object (before, during, and after it bounces on a surface)	Motion Sensor	1	CI-6742
		ball (hard rubber)	1	
		Base & Support Rod	1	ME-9355
		meter stick	1	
		<i>level (optional)</i>	1	
M06	Design Landing Bags: Determine the Relationship between Pressure and Volume	Pressure Sensor - Absolute syringe (included with sensor)	1	CI-6532A
		-----	1	
		glycerin	1 mL	
		plastic tubing (inc. with sensor) quick-release connector (inc.)	2.5 cm 1	
M07	Temperature at Different Locations	Temperature Sensor	1	CI-6505A
		<i>remote control model vehicle (opt.)</i>	1	
M08	Relative Humidity	Temperature Sensor	2	CI-6505A
		container, 100 mL	1	

		cardboard fan, about 15 by 15 cm	1	
		cheesecloth, about 5 by 5 cm	1	
		rubber band	2	
water, room temperature	100 mL			
M09	pH of Samples from Other Worlds	pH Sensor	1	CI-6507A
		beaker, 250 mL	3	
		container, about 200 mL	4	
		wash bottle	1	

		protective gear (PS)	1 set	

		buffer solution: high pH	100 mL	
		buffer solution: low pH	100 mL	
		distilled water	1 L	
		samples (e.g., bleach, detergent, milk of magnesia, egg white, milk, soda pop, vinegar, lemon juice)	4	
tissues or paper towels	6			

Earth Science Labs with Computers Equipment List, Part 2 (continued)

No.	Title	Equipment & Consumables	Qty.	Cat. #
M10	Test for Life: Measure a Chemical Reaction	Pressure Sensor - Absolute	1	CI-6532
		bottle or flask, 250 mL	1	
		connector for rubber stopper	1	640-030
		graduated cylinder	1	
		plastic tubing*	20 cm	640-021*
		quck-release connector*	1	640-032*
		rubber stopper, 1-hole, to fit bottle	1	(*inc. with sensor)

		protective gear (PS)	1 set	

		glycerin	1 mL	
		hydrogen peroxide (3% solution)	50 mL	
		water	150 mL	

For making soil samples				
Balance, Triple Beam	1	SE-8723		
spoon	1			
weighing paper	1			
Per Group				
container	2			
sand, dry	9.5 g			
yeast, dry active	0.5 g			

Preparation Information Summary

The following is a summary of information about each activity.

Teacher's Guide Preparation Summary — Part 1

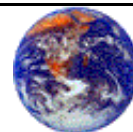

**Stewardship:
The Water Planet**

- Type: Type of activity, C = Collect, F = Field, L = Lab
- Pre-lab: Does the activity require preparation before the day of the activity?
- Cal.: Calibration of sensor(s)
- Prep. Time: Estimate of preparation time on the day of the activity
- Act. Time: Estimate of activity time
- Other: Miscellaneous reminders

No.	Title	Type	Pre-lab	Cal.	Prep. Time	Act. Time	Other
S01	Streams and Rivers	L	organize clean-up	no	30 min	45 min	
S02	Measure Stream Flow	F	safety, transportation, review data logging	no	30 min	30 min	
S03	Temperature of Flowing Water	F	safety, transportation, review data logging	no	30 min	30 min	
S04	Clarity and Turbidity in Water	C, L	safety, transportation	yes	30 min	30 min	
S05	Reducing Turbidity in Water	C, L	safety, transportation	yes	30 min	45 min	note 1
S06	pH of a Natural Water System	C, L	safety, transportation	yes	30 min	30 min	
S07	Acid Rain: Detection and Causes	L, C	safety	yes	2 hrs	30 min	

Notes

1. The water samples must be left undisturbed overnight.

Teacher's Guide Preparation Summary — Part 2



- Type: Type of activity, C = Collect, F = Field, L = Lab
- Pre-lab: Does the activity require preparation before the day of the activity?
- Cal.: Calibration of sensor(s)
- Prep. Time: Estimate of preparation time on the day of the activity
- Act. Time: Estimate of activity time
- Other: Miscellaneous reminders

No.	Title	Type	Pre-lab	Cal.	Prep. Time	Act. Time	Other
M01	Design and Construct a Model Rocket	L	gather materials	no	2 hrs	3 days	note 2
M02	Acceleration of a Model Rocket	F	safety, role playing, review data logging	no	15 min	45 min	
M03	Determine a Space Craft Surface	L	safety	no	15 min	30 min	note 3
M04	Map a Planetary Surface	L	safety, Motion Sensor tutorial	no	15 min	30 min	
M05	Acceleration of a Falling Object	L	review calibration	yes	15 min	30 min	
M06	Design Landing Bags	L	Keyboard Sampling	no	15 min	15 min	
M07	Temperature at Different Locations	F	review data logging	no	15 min	30 min	
M08	Relative Humidity	F	room temp. water	no	15 min	30 min	
M09	pH of Samples from Other Worlds	C	collect samples	yes	15 min	30 min	
M10	Test for Life: Measure a Chemical Reaction	L	prepare "soil" samples	no	1 hr	30 min	

Notes

2. Students can begin collecting materials weeks in advance.
3. Room temperature water is needed.

Quick Reference Guide for DataStudio

Create an Experiment

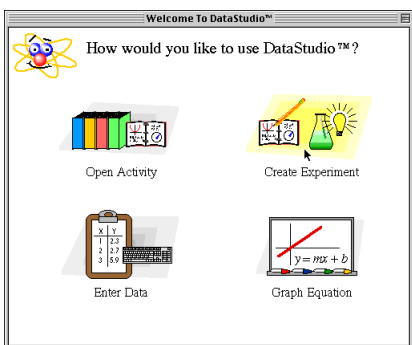

(1) Double-click a sensor.

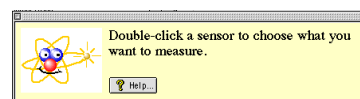

(2) Double-click a display.

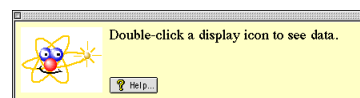

What You Want To Do	How You Do It	Button
Start recording data	Click the 'Start' button or select 'Start Data' on the Experiment menu (or on the keyboard press CTRL - R (Windows) or Command - R (Mac))	
Stop recording (or monitoring) data	Click the 'Stop' button or select 'Stop Data' on the Experiment menu (or on the keyboard press CTRL - . (period) (Win) or Command - . (Mac))	
Start monitoring data	Select 'Monitor Data' on the Experiment menu (or on the keyboard press CTRL - M (Win) or Command - M (Mac))	none

On the Graph Display	In the Graph Toolbar	Button
Re-scale the data so it fills the Graph display window	Click the 'Scale to Fit' button.	
Pinpoint the x- and y-coordinate values on the Graph display	Click the 'Smart Tool' button. The coordinates appear next to the 'Smart Tool'.	
'Zoom In' or 'Zoom Out'	Click the 'Zoom In' or 'Zoom Out' buttons.	
Magnify a selected portion of the plotted data	Click the 'Zoom Select' button and drag across the data section to be magnified.	
Create a Calculation	Click the 'Calculate' button	
Add a text note to the Graph	Click the 'Note' button.	
Select from the Statistics menu	Click the Statistics menu button	
Add or remove a data run	Click the 'Add/Remove Data' menu button	
Delete something	Click the 'Delete' button	
Select Graph settings	Click the 'Settings' menu button	

Experiment Setup Window

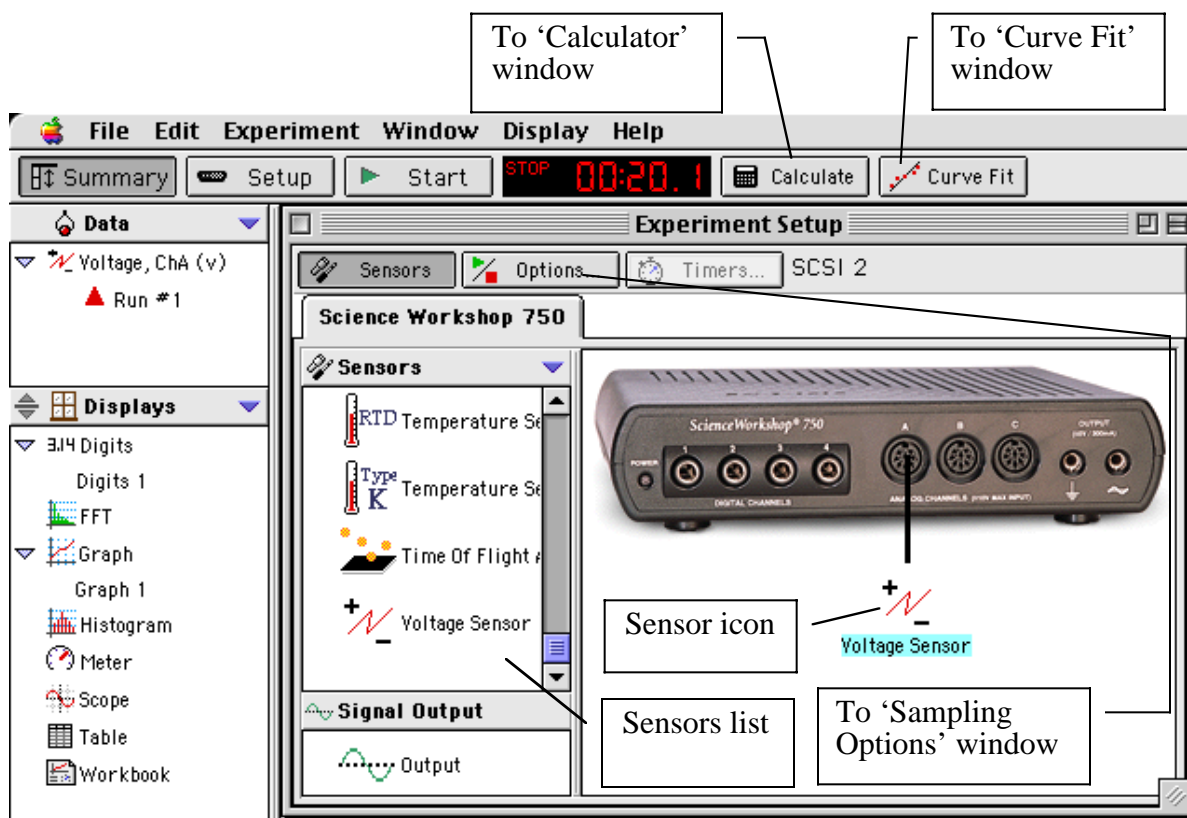

Graph Display

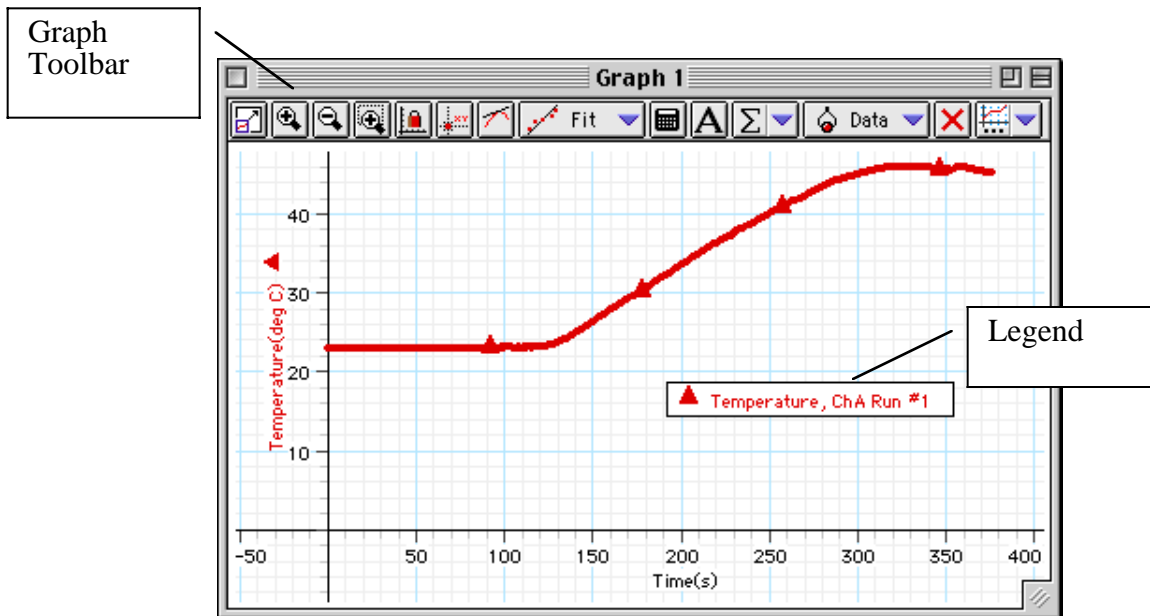

Instructions – Using the Interface and *DataStudio*

There are several features that make *DataStudio* a unique and powerful teaching tool for science and math. Section #1 covers the mechanics of the interface. Section #2 covers setting up an experiment with the software. Section #3 covers data analysis in more detail.

Hint: Working at a computer with *DataStudio* up and running while reading these instructions will bring a “hands-on” experience to the user and enhance the learning process.

Section # 1: *ScienceWorkshop 500* Interface

Data Logging with the *ScienceWorkshop 500* Interface Box

If you want to disconnect the interface box and use it for data logging, be sure to install four AA batteries in the bottom of the interface.

After you have set up an experiment in *DataStudio*, click the ‘Logging’ button in the Experiment Setup window in the software. Follow the instructions about saving your experiment. Disconnect the interface from the computer and the power supply. (Make sure that the switch on the back of the interface is in the ON position.)

After you have disconnected for logging, use the **LOG button** when you want to record data. Press the Log button once to begin data collection, and press it a second time to end that data run. Repeat this sequence to collect more sets of data points that will be called RUN #2, RUN #3, etc

Caution: In the remote data logging mode, the ON switch at the back of the box must remain on at all times. Loss of power will result in loss of data.

After you have collected data, reconnect the interface to the computer and the power supply.

Click the ‘Connect’ button in the Experiment Setup window in the software. Your data will download automatically.

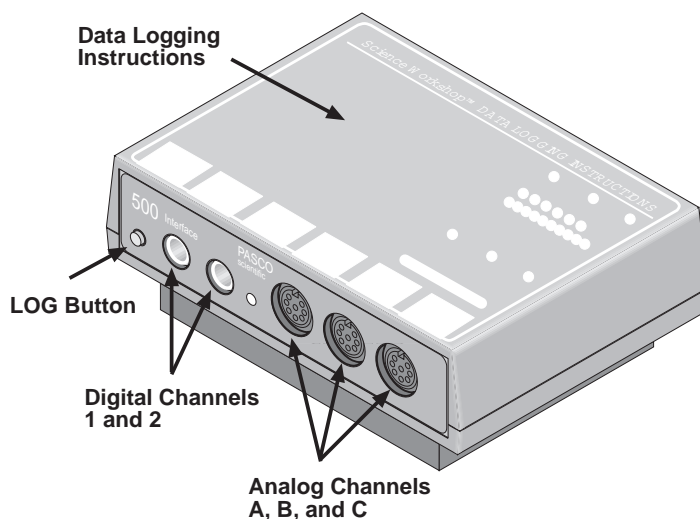

The **green LED (light-emitting diode)** on the front of the interface box indicates the mode of the interface box. A green light indicates that the power is ON. When you disconnect the interface for remote data logging the light will flash slowly when in the sleep mode and rapidly when you are collecting data. (Refer to the label on the top of the interface for details).

The **Analog Channels** allow up to three analog sensors to be plugged into the 500 interface. You can plug in an analog sensor’s DIN plug in only one way. The Temperature Sensor is an example of an analog sensor.

The **Digital Channels** allow one or two digital sensors to be plugged into the 500 interface. The Photogate and Motion Sensor are examples of digital sensors. For example, you can connect two Photogates or one Motion Sensor to a 500 interface.

Section #2: Setting Up Your Own Experiment in *DataStudio*

The Summary List and the Setup Window

Start *DataStudio*. In the 'Welcome to *DataStudio*TM' window, click 'Create Experiment'.

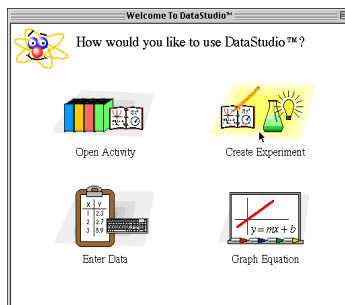

The first step to becoming proficient with *DataStudio* is to understand the Summary List and the Experiment Setup window. The Summary List shows runs of data (under 'Data') and the available displays (under 'Displays'). The Experiment Setup window shows the list of sensors (under 'Sensors') and the interface that is connected.

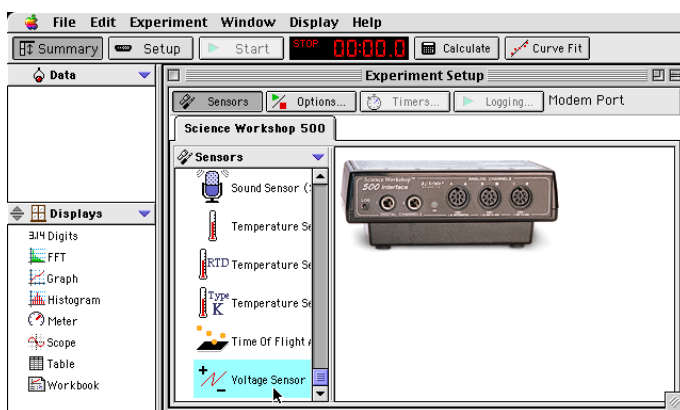

Select a sensor. The sensors are listed by name. Scroll through the list to find the 'Voltage Sensor', and then double-click the sensor to select it.

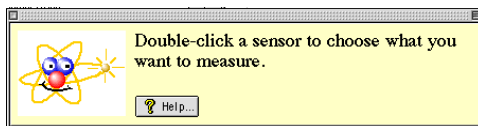

The Voltage Sensor icon appears below Channel A of the interface, and 'Voltage, ChA (v)' appears in the Data list.

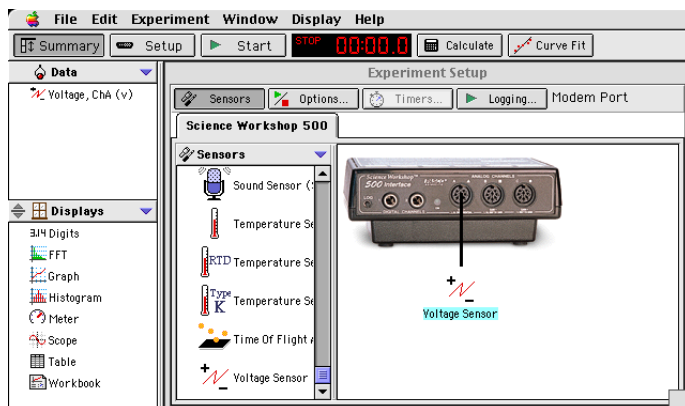

Now, select a display. Double-click 'Graph' in the Displays list.

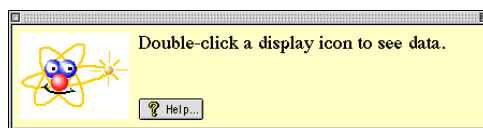

Graph 1 opens, and 'Graph 1' appears in the Displays list. Also, 'Voltage, ChA NO DATA' appears in the Graph's legend.

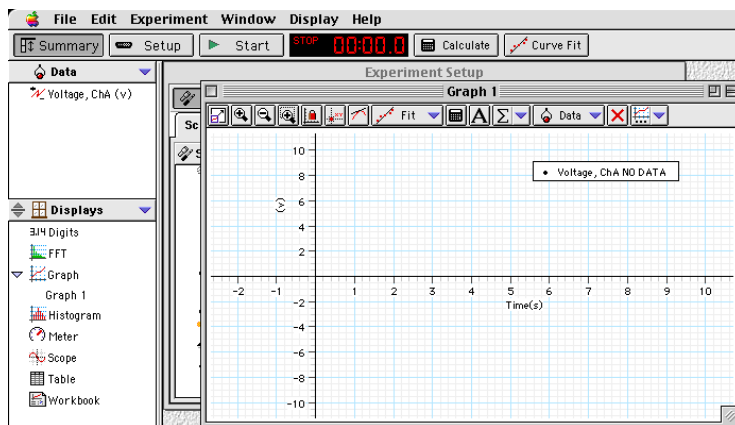

appears in the Graph's legend.

Finally, click the 'Start' button () to begin recording data. When you are finished, click 'Stop'.

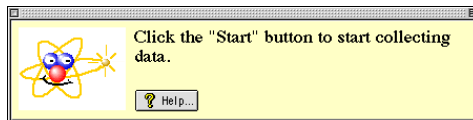



The Menu Bar **File Edit Experiment Window Display Help**

The **menu bar** at the top of the Experiment Setup window is very similar to menus bars found in Macintosh® and Windows® programs.

- Use the **File** menu to make a new activity, open an activity, save an activity, save an activity with a specific filename or in a specific location, import data, export data, select options (for saving *to* or opening *from* a particular directory), setup the page for printing, print, or quit.
- Use the **Edit** menu to undo, cut, copy, paste, delete, or select all.
- Use the **Experiment** menu to control the data collection, delete the last data run, disconnect for data logging or re-connect after data logging, set sampling options, open a new empty data table, or add a display.
- Use the **Window** menu to close, minimize, or maximize a window, to tile or cascade windows, or to select a window so it ‘pops-to-the-top’.
- Use the **Display** menu to export data or a picture of a display or to activate any of the buttons in a display’s toolbar.
- Use the **Help** menu to open the online help files, see the most recent help message, turn on or turn off the tips and confirmation windows, or change the license key.

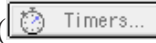
Features of the Experiment Setup Window

In addition to the Sensors list, the Experiment Setup window has a button to open the ‘Sampling Options’ window () , a button to open the ‘Timers’ window () (for use with Photogates), and a ‘Logging’ button () for use when you disconnect the interface for data logging.

Note: After you click the ‘Logging’ button, a ‘Connect’ button () appears. If you disconnect for data logging and then re-connect after collecting data, click the ‘Connect’ button after you re-connect the interface to the computer and power supply.



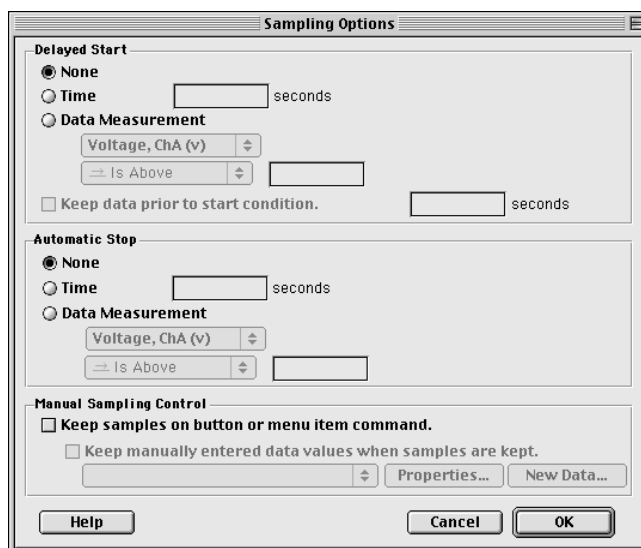

Use the ‘Sampling Options’ window to set a ‘Delayed Start’, an ‘Automatic Stop’ or to set the ‘Manual Sampling Control’.



Section #3: Data Analysis

DataStudio offers several ways to analyze data:

- Use the built-in analysis tools in the Graph display toolbar
- Use the 'Calculator' to create calculations based on your measured data or on a range of numbers that you select.
- Use the 'Curve Fit' to compare your data to mathematical models.

In the **Graph display toolbar**, the built-in analysis tools include the 'Smart Tool' button () , the 'Slope Tool' button () , the 'Fit' menu button () , the 'Calculate' button () , and the 'Statistics' menu button () .

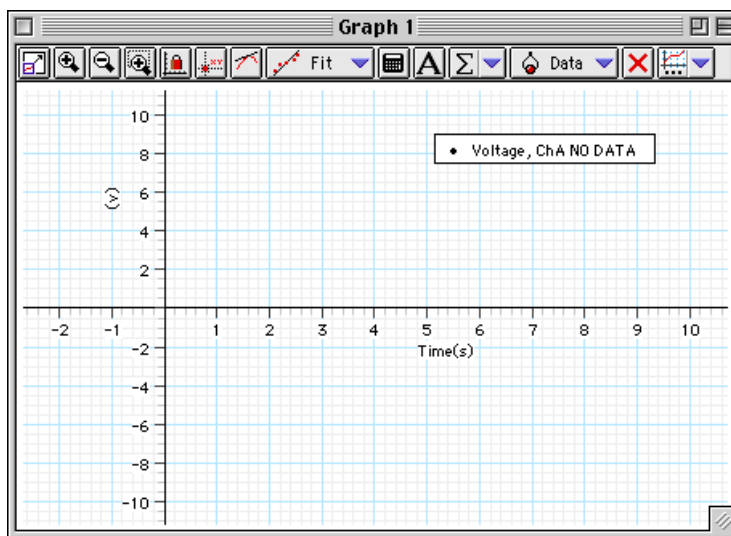

- Use the 'Smart Tool' to see the coordinates of any point.
- Use the 'Slope Tool' to see the slope of a line tangent to a point on a curve.
- Use the 'Fit' menu button to select a mathematical model.
- Use the 'Calculate' button to create a calculation on the data in your Graph.
- Use the 'Statistics' menu button to select basic statistics such as 'Minimum' or 'Maximum' or to find the area under a curve.

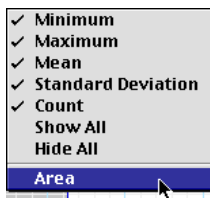
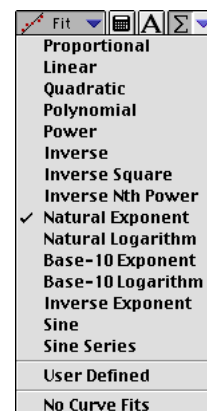

Click the 'Calculate' button in the main toolbar () to open the 'Calculator' window:

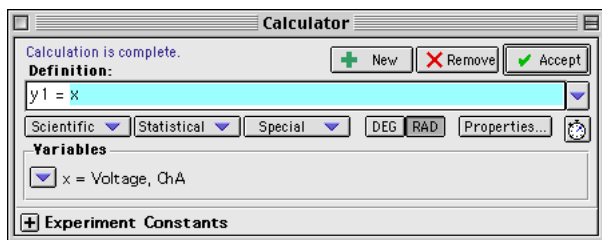

Use the 'Definition:' area to create your own calculation, or use the 'Scientific', 'Statistical', or 'Special' menus to select a specific calculation to apply to your data. After you have created the calculation, click 'Accept'. Your calculation will appear in the Data list. You can drag your calculation to a Graph display, for example

Click the 'Curve Fit' button in the main toolbar () to open the 'Curve Fit' window. Click the 'New' button.

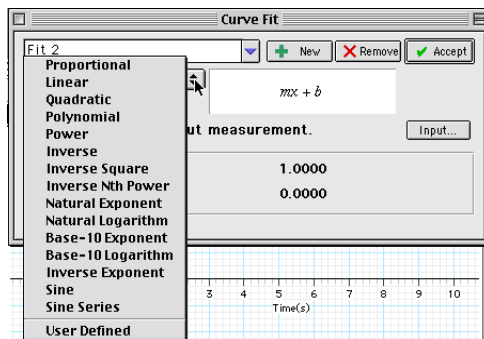

Select a mathematical model, or select 'User Defined' to create your own.

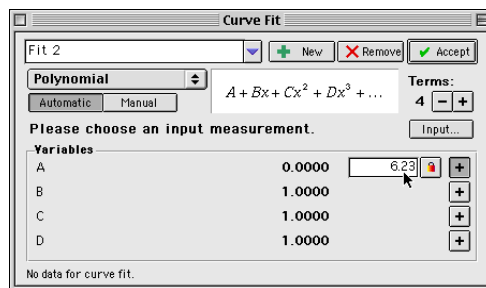



You can enter values for the coefficients or 'lock' a coefficient. After you have created the mathematical model, click 'Accept'. Your curve fit will appear in the Data list. You can drag your curve fit to a Graph display, for example.

Online Help









Click 'Contents' or 'Search...' in the Help menu to open the online help file. You can use the online help file to learn about any button, icon, menu, control, function or feature of the program.

Quick Reference Guide for *ScienceWorkshop*

In the Experiment Setup Window:

What You Want To Do To	How You Do It	What the Button Looks Like
Begin recording data	Click the Record (REC) button or select Record on the Experiment menu (or on the keyboard press CTRL - R (Windows) or Command - R (Mac))	
Stop recording (or monitoring) data	Click the Stop (STOP) button or select Stop on the Experiment menu (or on the keyboard press CTRL - . (period) (Win) or Command - . (Mac))	
Begin monitoring data	Click the Monitor (MON) button or select Monitor on the Experiment menu (or on the keyboard press CTRL - M (Win) or Command - M (Mac))	

On the Graph Display:

Re-scale the data so it fills the Graph display window	Click the Graph display and click the Autoscale button	
Pinpoint the x- and y-coordinate values on the Graph display	Click the Smart Cursor button and move the cross hairs onto the graph (the exact values for the coordinates will appear next to each axis label)	
Magnify a selected portion of the plotted data	Click the Magnify button, and drag across the data section be to magnified	
Activate the Statistics Menu	Click the Statistics button	
Open the Statistics Menu	Click the Statistics Menu button	
See a list of all your Data Runs	Click the Data button	
Select Data Runs for display	Click the Run # in the Data menu (Shift-click to select more than one run)	
Add another plot to your Graph display	Click the Add-A-Plot button and select the desired input from the pop-up menu	
Import match data and plot it on the Graph display	Copy the match data to the clipboard, click the Plot Data Options button, and click Paste, OK, OK	

Experiment Setup Window

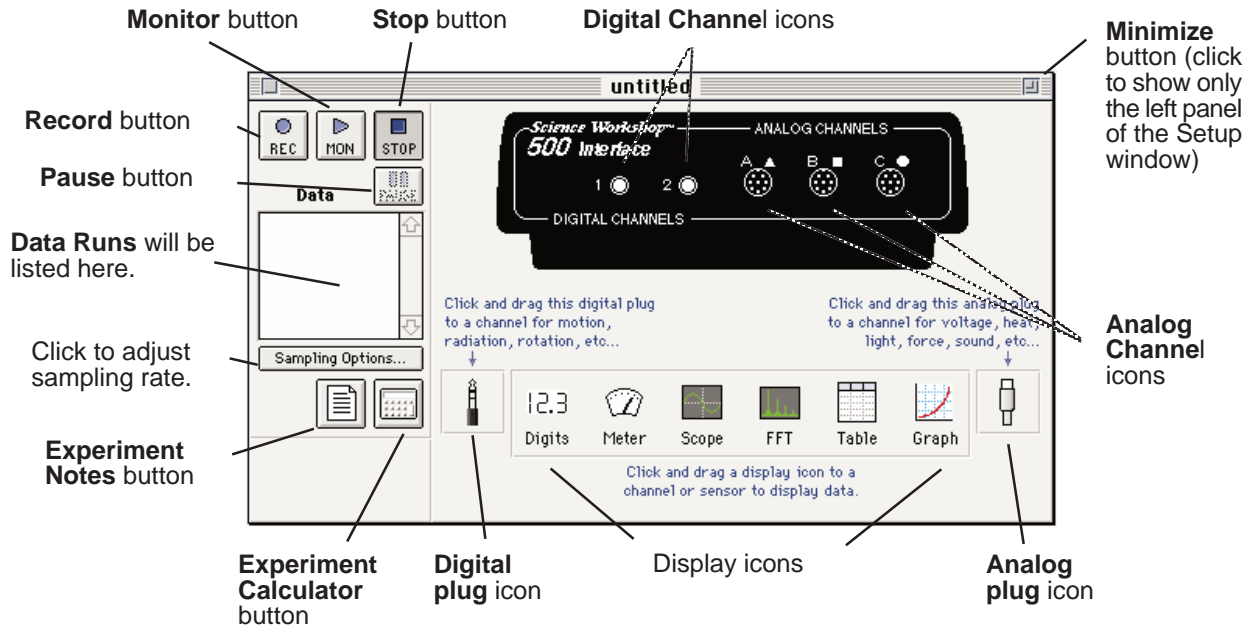

Graph Display

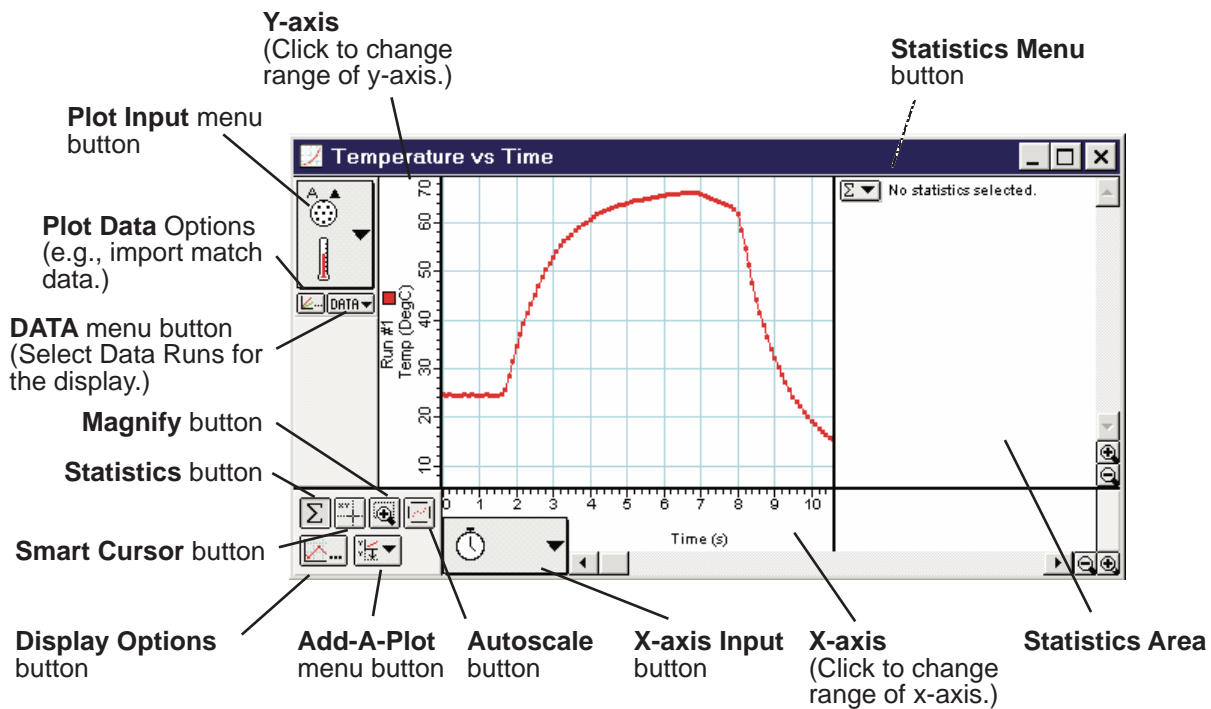

Instructions – Using *ScienceWorkshop*®

There are several features that make *ScienceWorkshop* a unique and powerful teaching tool for science and math. Section #1 covers the mechanics of the software and hardware. Section #2 covers the data analysis tools in more detail.

Hint: Working at a computer with *ScienceWorkshop* up and running while reading these instructions will bring a “hands-on” experience to the user and enhance the learning process. You should keep the *Quick Reference Guide for ScienceWorkshop* available as a reference.

Section # 1: Experiment Setup

The *ScienceWorkshop* 500 Interface Box

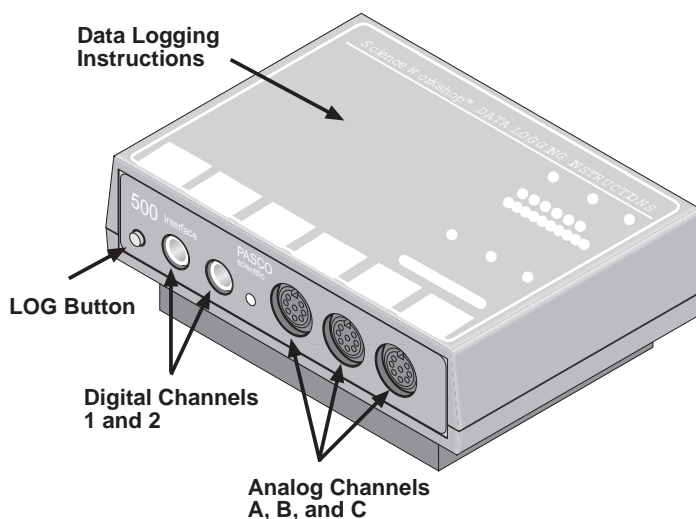

The **green LED (light-emitting diode)** on the front of the interface box indicates the mode of the interface box. A green light indicates that the power is ON. When you disconnect the interface for remote data logging the light will flash slowly when in the sleep mode and rapidly when you are collecting data. (Refer to the label on the top of the interface for details).

The **Analog Channels** allow up to three analog sensors to be plugged into the 500 interface. You can plug in an analog sensor's DIN plug in only one way. The Temperature Sensor is an example of an analog sensor.

The **Digital Channels** allow one or two digital sensors to be plugged into the 500 interface. The Photogate and Motion Sensor are examples of digital sensors. For example, you can connect two Photogates or one Motion Sensor to a 500 interface.

The Experiment Setup Window

The first step to becoming proficient with *ScienceWorkshop* is to understand the various icon and buttons in the **Experiment Setup** window. The window is automatically displayed whenever a new *ScienceWorkshop* file is opened. If you get a “Can’t find interface box” message, the interface is either missing or not properly connected. Be sure that the power to the interface box is ON and that the connector cables are secure.

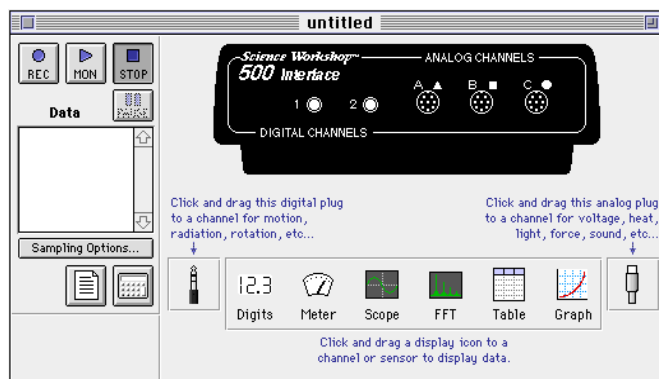

The Menu Bar **File Edit Experiment Display**

The **menu bar** at the top of the Experiment Setup window is very similar to menus bars found in Macintosh® and Windows® programs.

- Use the **File** menu to open, close, save, print, and import data.
- Use the **Edit** menu to copy, cut, clear, and paste data or runs of data.
- Use the **Experiment** menu to control the data collection.

You can also use the Experiment menu to **Record, Monitor, Pause, or Stop** data collection (as if you had used the buttons in the Experiment Setup window). You can use this menu to access the sampling options, disconnect/connect (for remote data logging), display the Experiment Setup window, or go to the Experiment Notes and Calculator windows.

- Use the **Display** menu to select any of the six display windows (either to set up a new display or toggle to a display already in use).

Features of the Experiment Setup Window



The **Record button** is in the top left corner of the Experiment Setup window. Press this button to collect data and store the data in memory. The flashing bar below the button shows when *ScienceWorkshop* is collecting data.



The **Monitor Data button** is next to the **Record** button. Press this button to collect and display data in a *view* mode only. None of the data are saved in memory. For example, use this feature when you want to check to see if a sensor is working properly, and also when viewing data in the Scope display.



Press the **Stop button** to stop data collection in both the record and monitor modes.



Press the **Pause button** to temporarily interrupt data collection. Press it again when you want to continue collecting data.

Sampling Options... Press the **Sampling Option button** to open a window where you can select the Periodic Samples rate, the Start and Stop Conditions, and Keyboard Sampling. The default Periodic Samples rate is 10 samples per second (10 Hz) for an analog sensor and 10,000 samples per second for a digital sensor. You can vary the Periodic Samples rate from 20,000 Hz (Fast) to 3600 seconds (Slow).

Suggested Periodic Sampling rates for common measurements:

Temperature Sensor	2 – 10 Hz
Light Sensor	10 Hz
Voltage Sensor	10 Hz



Press the **Experiment Calculator button** to open the Experiment Calculator window that allows you to do mathematical operations on collected data. You can also use it as a stand-alone calculator.



Drag the **digital plug icon** to Digital Channel 1 or 2 to add a digital sensor to the Experiment Setup window, and then select the correct digital sensor from the list of sensors that opens. Click **OK** to return to the Experiment Setup window.



Drag the **analog plug icon** to Analog Channel A, B, or C to add an analog sensor to the Experiment Setup window. Then select the correct analog sensor from the list of sensors that opens. Click **OK** to return to the Experiment Setup window.

Setting Up Your Own Experiment in *ScienceWorkshop*

1. Drag an **analog plug icon** or a **digital plug icon** to the icon that corresponds to the channel on the *500* Interface box that you plugged the sensor into.

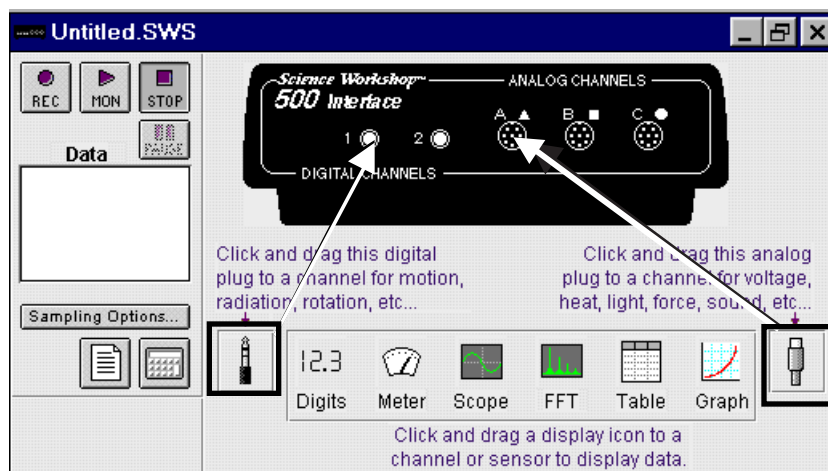

2. Choose the sensor from the sensor list that pops up. Click **OK** to return to the Experiment Setup window.

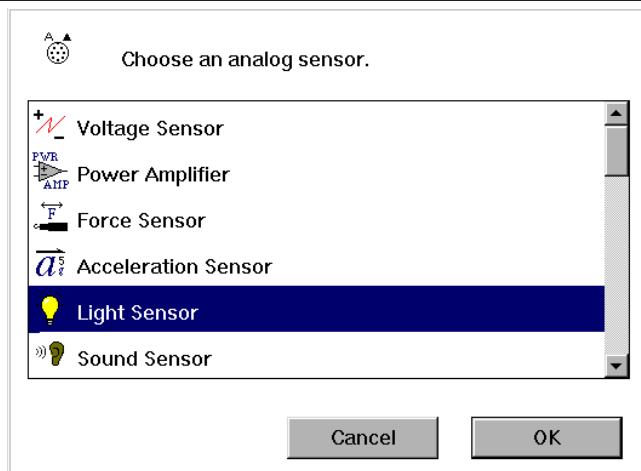

3. Drag a display icon to the Sensor icon.

You are ready to collect data!

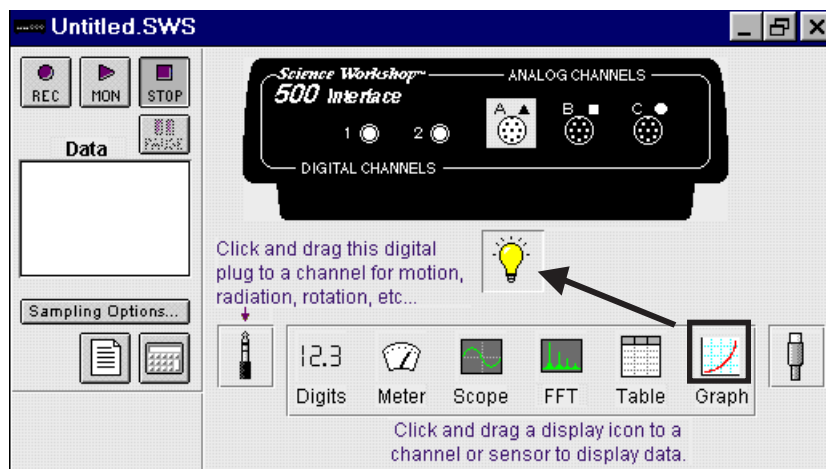

Note: *ScienceWorkshop* has many advanced features. Refer to the *ScienceWorkshop* User's Guide that came with the interface for more information.

Section #2: Data Analysis

Analysis: The Smart Cursor







The Smart Cursor allows you to investigate individual points on a graph.

Procedure: Click the **Smart Cursor** in any display that has the Smart Cursor icon (for example, the Graph display). The cursor changes to a cross hair and the y and x values for that individual position will be displayed on the y-axis and x-axis. If you desire to have the change in y or x coordinates displayed, click-and-drag the Smart Cursor over the desired area. The difference ($y_2 - y_1$ and $x_2 - x_1$) will be displayed on the y-axis and x-axis. (This ability to display the change in x and the change in y in a selected area is called the delta feature.)

The Statistics Tool 

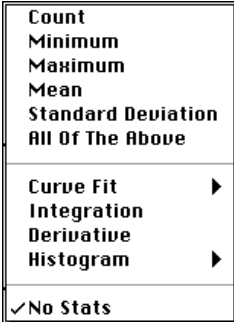
The Table and Graph displays have built-in statistics. Click the **Statistics button** to open the statistics area at the bottom of a Table or on the right side of a Graph.

<p>Statistics menu for a Table display</p>	
<p>In the Graph display, click the Statistics Menu button to see the statistics options.</p>	
<p>Statistics menu for a Graph display</p>	
<p>Curve Fit submenu</p>	
<p><i>Linear Fit</i> will generate a basic slope equation with the slope of the best-fit line being the a2 value in the display.</p>	

The Experiment Calculator

Use the **Experiment Calculator** feature of *ScienceWorkshop* to create a new calculation that is based on the input data. For example, if data is displayed in degrees Celsius, you can use the calculator to create a calculation to display the temperature data in degrees Fahrenheit or degrees Kelvin.

To set up a calculation, click the **Calculator button**  in the Experiment Setup window. You can also open the Experiment Calculator by selecting **Calculator Window** from the **Experiment** menu.

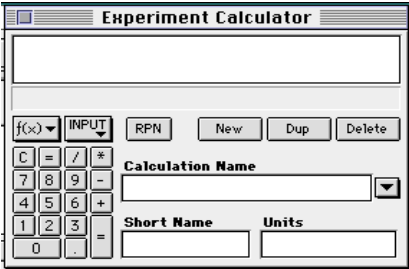
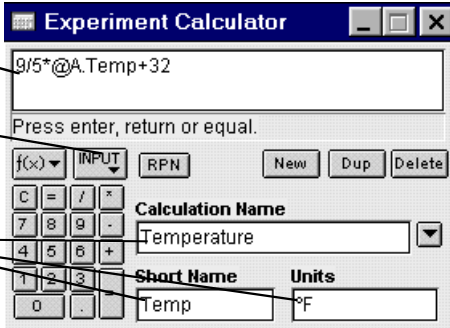
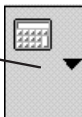
<p>Experiment Calculator window</p>	
<p>Example: Converting the temperature data from degrees Celsius to degrees Fahrenheit for plotting on the Graph display.</p>	<ol style="list-style-type: none"> 1. Type the formula here (Select the variable to be modified from the Input Menu) 2. Fill in these dialog boxes 3. Click = or press ENTER 
<p>Changing the plotting parameters of the Graph display</p>	<ol style="list-style-type: none"> 4. On the Graph display, click the Plot Input Menu button, and select Calculations, Temperature, (Temp °F)  <p>(Temperature will be plotted in °F)</p>

Note: The values for this calculation can also be displayed in any Table, Digits, or Meter display. To do this, select **Calculations, Temperature, (Temp °F)** from the **Input** menu of the display.

Light Sensor

The Light Sensor measures relative light intensity. The sensing element is a photodiode that produces a voltage proportional to the light intensity across a wide spectrum ranging from 320 nanometers to 1100 nanometers (nm).

The sensor includes a cable for connecting to the interface. The sensor has one built-in control.

Gain Select Switch: Use the gain select switch to set the maximum input light levels of the sensor. The three settings are as follows.

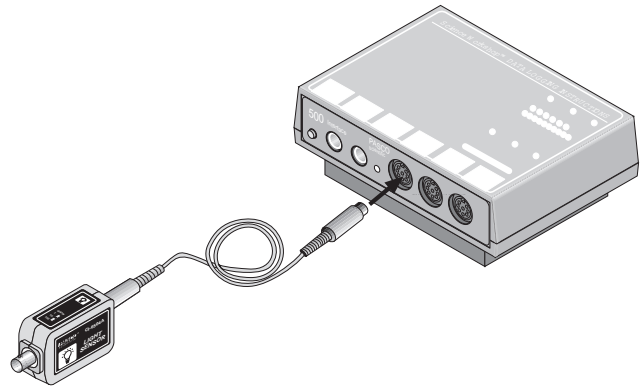

Gain Select setting	Maximum Input (lux)
1	500
10	50
100	5

Set up the sensor with the interface

- Plug one end of the DIN-to-DIN cable into the sensor and then connect the other end of the cable into **Analog Channel A** on the interface.
- Note: You can connect the sensor directly into the interface if needed.

Set up the sensor in the software

- In *DataStudio*, double-click the name of the sensor in the Sensors list in the Experiment Setup window. **Result:** The sensor icon appears below Channel A of the interface. The sensor's parameters appear in the Data list.
- In *ScienceWorkshop*, click-and-drag the 'analog sensor plug' icon to the Channel A icon in the Experiment Setup window, select the name of the sensor from the list of sensors and click 'OK' to return to the Experiment Setup window. **Result:** The sensor's icon appears below Channel A of the interface.

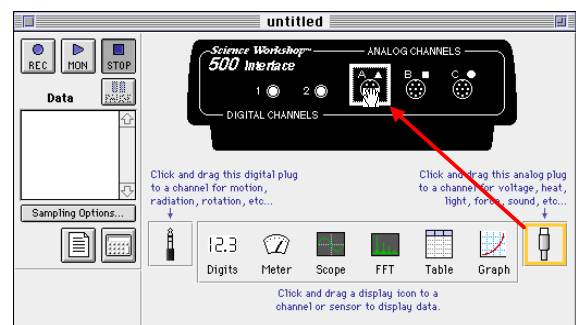
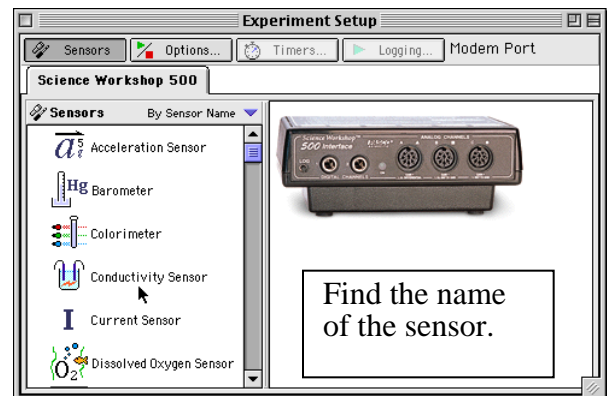

Set up a display

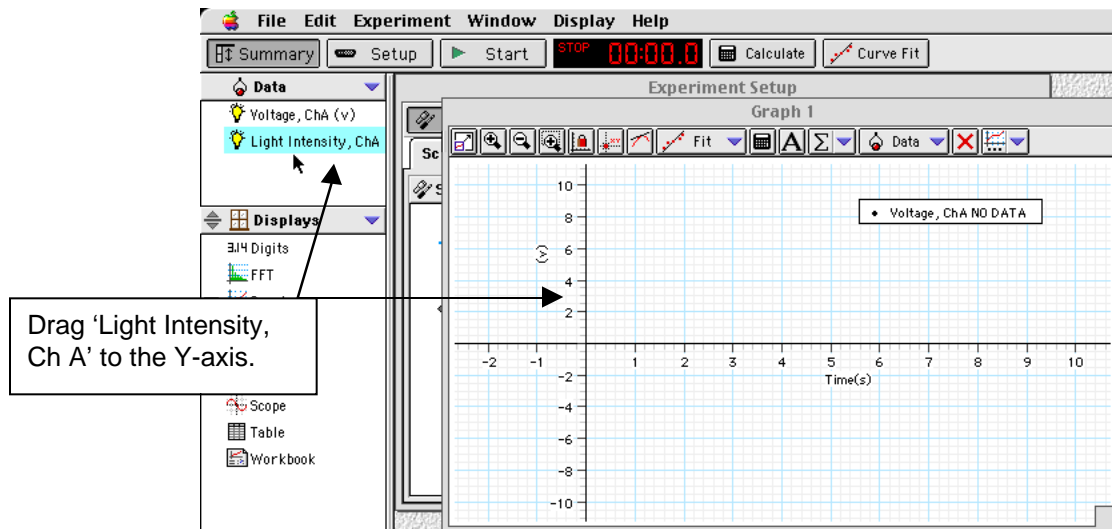

- In *DataStudio*, double-click the 'Graph' icon in the Displays list. **Result:** The display automatically shows voltage versus time. To make the Graph show light intensity instead of voltage, click-and-drag 'Light Intensity, ChA' from the Data list to the vertical axis of the Graph display.

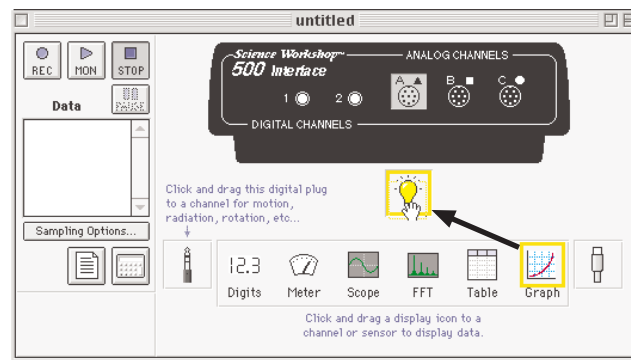

- In *ScienceWorkshop*, click-and-drag the 'Graph display' icon to the Light Sensor icon in the Experiment Setup window. **Result:** The Graph display shows 'Intensity (% max)' versus Time (s).



Start recording data

- Set the GAIN switch on the top of the Light Sensor to 1.
- In *DataStudio*, click the 'Start' button (). In *ScienceWorkshop*, click the 'REC' button ().
- Move your hand over the Light Sensor, point the sensor at different light sources, and watch the results on the Graph display.

Stop recording data.

- Click 'Stop' to end data recording.

Motion Sensor II

The Motion Sensor II is a sonar ranging device. It sends out ultrasonic pulses and detects echoes of these pulses that are reflected from an object. The sensor includes a cable for connecting to the interface. One end of the cable connects to the sensor. The other end has two stereo phone plugs that connect to the interface. The yellow plug carries the 'transmit pulse' signal from the interface. The other plug returns the echo to the interface.

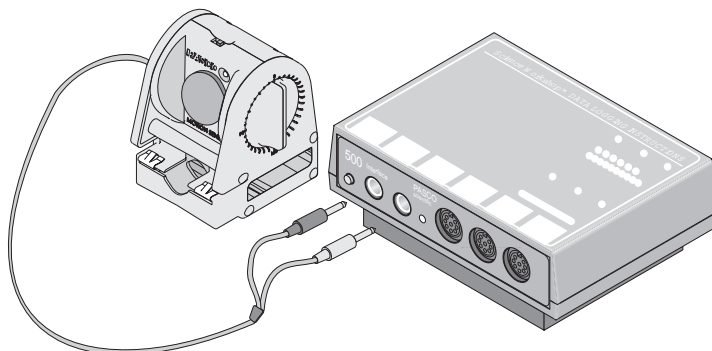

The sensor can measure objects as close as 15 cm (0.15 m) or as far as 8 m. You can use the software to set the number of pulses (the 'trigger rate') from as few as five per second to as many as 120 per second.

The sensor has one built-in control.

Narrow/Standard (Std.) Switch: Set the switch to *Narrow* for measuring highly reflective targets (such as a PASCO cart) at distances of 2 m or less. Set the switch to *Std* for measuring targets that are poor reflectors or for distances longer than 2 m.

Note: Use the 'Standard' setting if the *DataStudio* or *ScienceWorkshop* file has a 'Start Condition' for the Motion Sensor. On the Standard setting, you may need to tilt the sensor up by five or ten degrees to avoid reflections from the front of the sensor housing or from a surface underneath the sensor.

For this activity you will need a meter stick and a highly reflective target, such as a book.

Set up the sensor

- Plug the modular connector on one end of the interface cable into the side of the Motion Sensor. Connect the yellow phone plug into **Digital Channel 1** on the interface. Connect the other phone plug into **Digital Channel 2**.

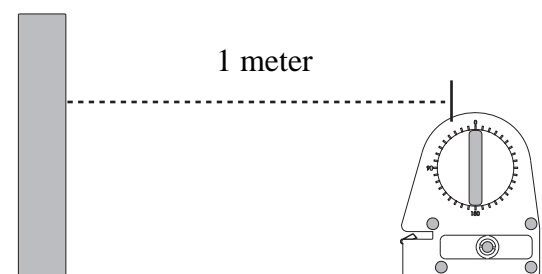

- Place the sensor exactly one meter away from a target. Arrange the sensor and target so the pulses from the sensor can reflect from the target and be detected by the sensor.

Set up the sensor in the software

- In *DataStudio*, double-click the name of the sensor in the Sensors list in the Experiment Setup window. **Result:** The sensor icon appears below the digital channels of the interface. The sensor's parameters (e.g., Position, etc.) appear in the Data list.

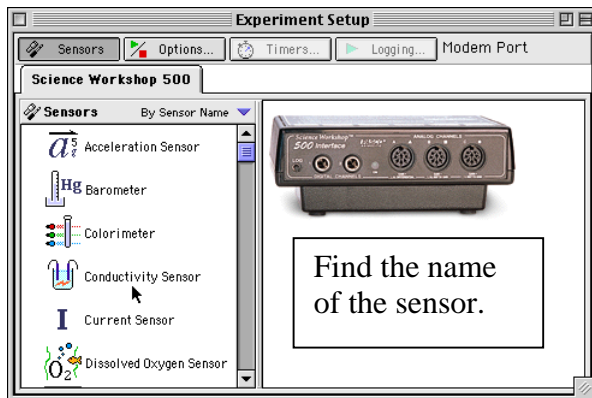

- In *ScienceWorkshop*, click-and-drag the 'digital sensor plug' icon to the Channel 1 icon in the Experiment Setup window, select the name of the sensor from the list of sensors and click 'OK' to return to the Experiment Setup window. **Result:** The sensor's calibration window opens and the sensor begins to click a few times per second.

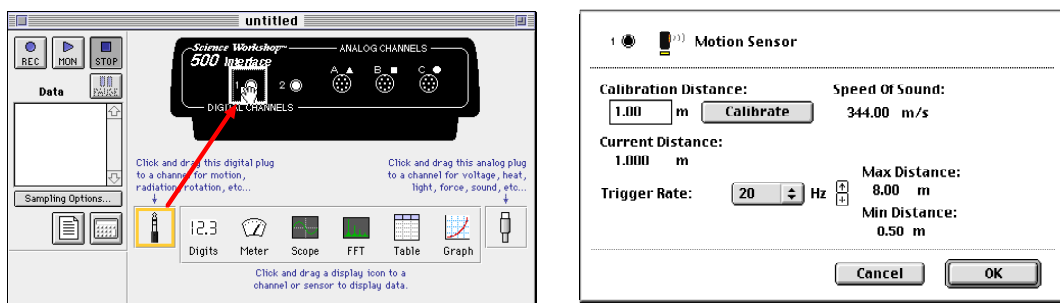

Calibrate the sensor

The general method for calibrating the motion sensor is as follows:

- In the *DataStudio* Experiment Setup window, double-click the sensor's icon. **Result:** The Sensor Properties window opens.

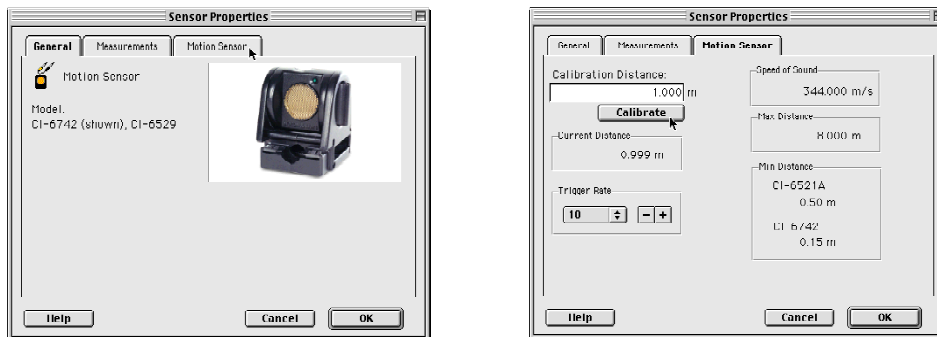

- Click the 'Motion Sensor' tab. **Result:** The calibration window opens and the sensor begins to click a few times per second.



3. Calibrate the software.

- **First**, make sure that the sensor is one meter from the target.
 - **Second**, click the 'Calibrate' button in the Motion Sensor window. **Result:** The software calculates the speed of sound based on the calibration distance (one meter) and the round trip time of the pulse and echo
4. Click 'OK' to return to the Experiment Setup window.

Set up a display

- In *DataStudio*, double-click the 'Graph' icon from the Displays list. **Result:** The Graph display shows position versus time.
- In *ScienceWorkshop*, click-and-drag the 'Graph' display icon to the sensor's icon in the Experiment Setup window. Select 'Position, x (m)' from the list of and click 'Display'. **Result:** The Graph display shows position versus time.

Start recording data

- In *DataStudio*, click the 'Start' button (). In *ScienceWorkshop*, click the 'REC' button ().
- Move a target (such as a book) back-and-forth in front of the sensor. Watch the results on the Graph display.

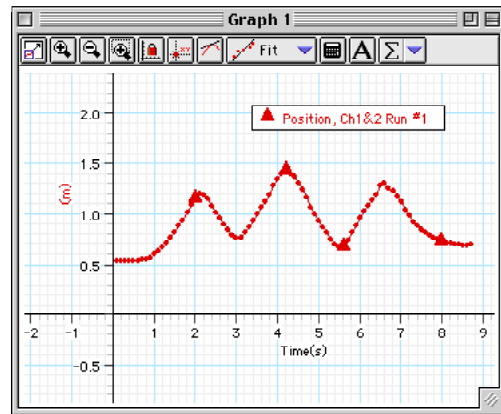
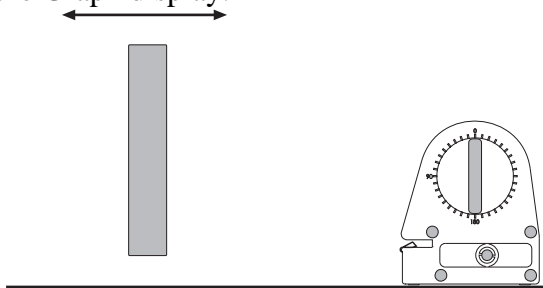
**Stop recording data**

- Click 'Stop' to end data recording.

pH Sensor

The pH Sensor has an amplifier and a pH electrode. The electrode produces a voltage that is proportional to the hydrogen ion concentration in a solution. (Store the electrode in its soaker bottle when you are not using it.) The amplifier converts the electrode voltages into the voltages required by the *ScienceWorkshop* interface.

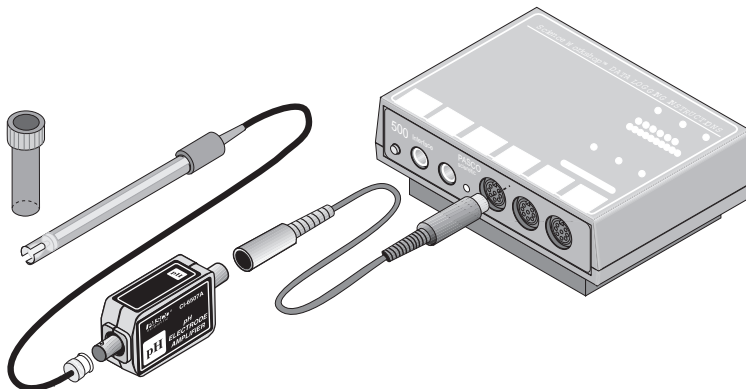

For this activity you will need a cup or beaker, some cranberry juice (or other fruit juice), and an antacid tablet (e.g., Alka-Seltzer®). Fill the cup about half full with juice. Break the antacid tablet in half.

1. Set up the sensor.

- Plug the DIN connector cable into the sensor's DIN plug and then connect the cable into **Analog Channel A** on the interface.
- Connect the pH electrode to the BNC port on the pH Sensor. Line up the connector on the end of the cable with the pin on the BNC port. Push the connector onto the port and then twist the connector clockwise about one-quarter turn until it clicks into place.
- Put the end of the pH electrode into the juice.

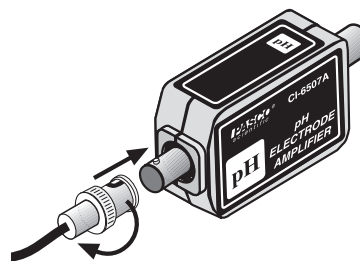

2. Set up the sensor in the software.

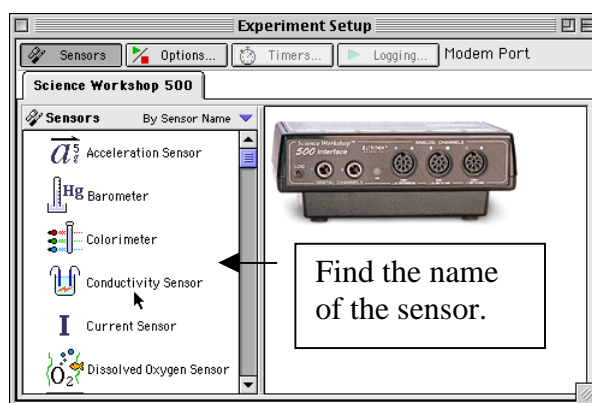

- In *DataStudio*, double-click the name of the sensor in the Sensors list in the Experiment Setup window.

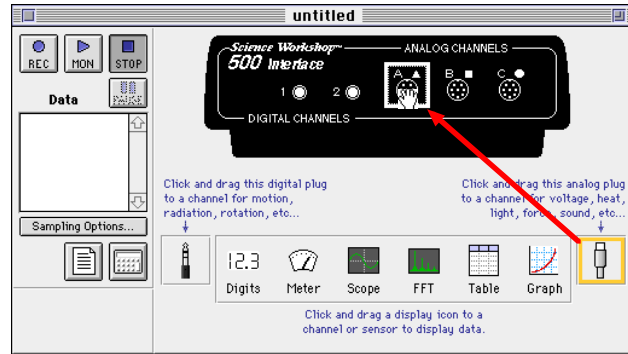

- The sensor icon will appear below Channel A of the interface. The sensor's parameters (e.g., pH, Voltage, etc.) will appear in the Data list.

- In *ScienceWorkshop*, click-and-drag the 'analog sensor plug' icon to the Channel A icon in the Experiment Setup window, select the name of the sensor from the list of sensors and click 'OK' to return to the Experiment Setup window. The sensor's icon will appear below Channel A of the interface.



- Set up a Graph display of pH versus Time.
 - In *DataStudio*, click-and-drag the 'Graph' icon from the Displays list and drop it on 'pH' in the Data list.
 - In *ScienceWorkshop*, click-and-drag the 'Graph' display icon to the sensor's icon in the Experiment Setup window. Select 'pH (pH)' and click 'Display'.
- Start recording data.
 - Put half of an antacid tablet into the fruit juice and stir with the end of the pH electrode.
 - In *DataStudio*, click the 'Start' button (). In *ScienceWorkshop*, click the 'REC' button ().
 - Note the change in pH in the Graph display.
- After two minutes, stop recording data. (Click 'Stop' to end data recording.)

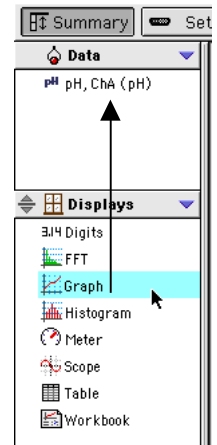

Pressure Sensor

The Pressure Sensor includes a cable, a syringe, tubing, and connectors for the tubing.

The sensor can measure pressures as high as 700 kilopascals, or about seven atmospheres. It is designed for non-corrosive gases. Do not put liquids into the sensor.

For this activity you will need two drops of glycerin, the syringe, a short piece of plastic tubing, and a quick-release connector. (Note: The syringe, tubing, and connector are included with the sensor.)

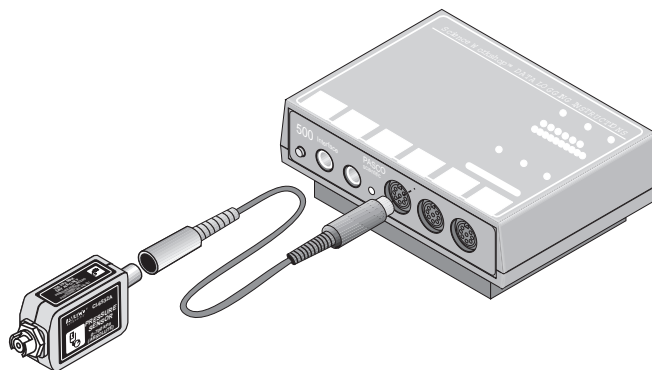

Set up the sensor

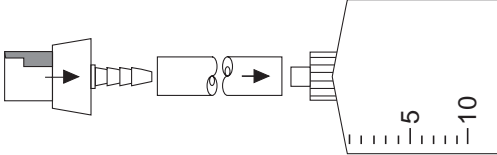
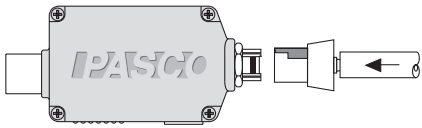
- Plug the DIN connector cable into the sensor's DIN plug and then connect the cable into **Analog Channel A** on the interface.
- Prepare the syringe. Cut a short piece of tubing (about 2 cm). Put a drop of glycerin on the barb end of a quick-release connector. Put the barb end of the connector into one end of the tubing. Put a drop of glycerin on the tip of the syringe. Put the tip of the syringe into the other end of the tubing. Pull out the piston so it is at about the 10 cc mark.
 
- Connect the syringe to the sensor. Line up the quick-release connector with the pressure port on the sensor. Push the connector onto the port and turn the connector clockwise until it clicks.
 

Set up the sensor in the software

- In *DataStudio*, double-click the name of the sensor in the Sensors list in the Experiment Setup window.
- The sensor icon will appear below Channel A of the interface. **Result:** The sensor's parameters (e.g., Pressure) appear in the Data list.

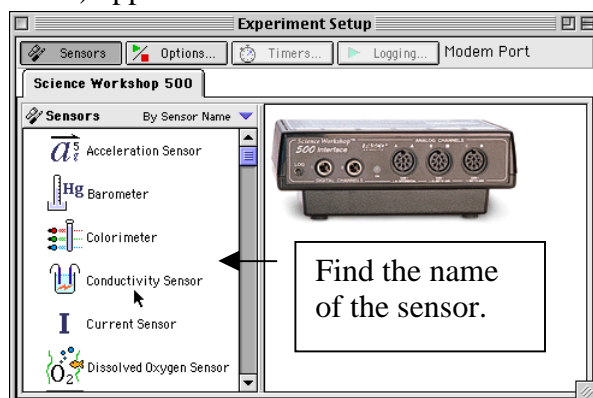

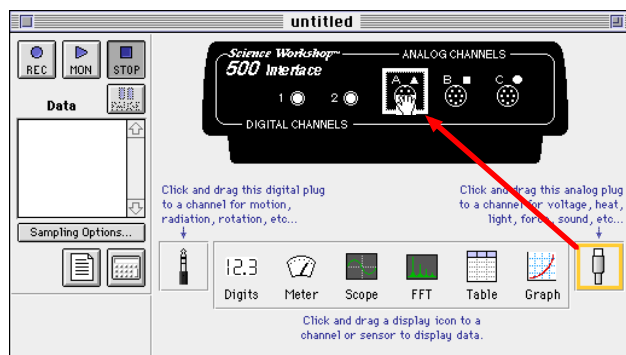

- In *ScienceWorkshop*, click-and-drag the 'analog sensor plug' icon to the Channel A icon in the Experiment Setup window, select the name of the sensor from the list of sensors and click 'OK' to return to the Experiment Setup window. Result: The sensor's icon appear belows Channel A of the interface.



Set up a Graph display of Pressure versus Time

- In *DataStudio*, double click the 'Graph' icon in the Displays list. **Result:** The display automatically shows pressure versus time.
- In *ScienceWorkshop*, click-and-drag the 'Graph' display icon to the sensor's icon in the Experiment Setup window. **Result:** The display automatically shows pressure versus time.

Start recording data

- In *DataStudio*, click the 'Start' button (). In *ScienceWorkshop*, click the 'REC' button ().
- After a few seconds, push the piston in so it is at the 5 cc mark. Then pull the piston out so it is at the 20 cc mark.

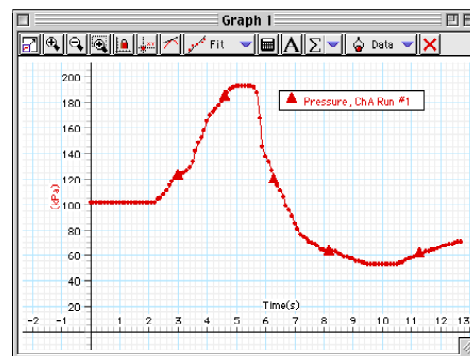
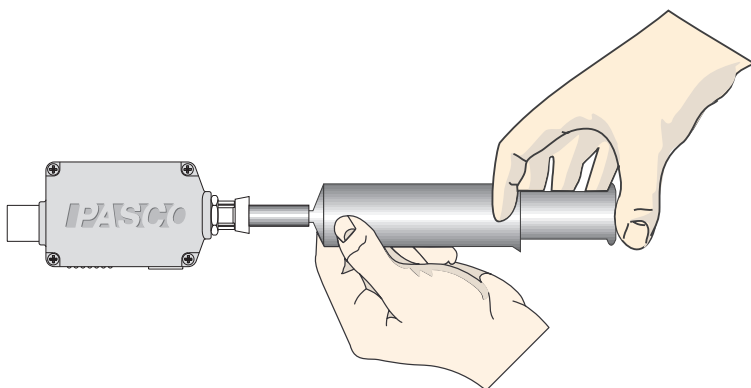

- Note the change in pressure in the Graph display.

Stop recording data

- Click 'Stop' to end data recording.

Temperature Sensor

The Temperature Sensor has a temperature sensitive integrated circuit in its tip that produces a voltage that is proportional to temperature. The sensor is covered with Teflon® tubing that is very chemical resistant. The sensor includes a removable Teflon sensor cover that is highly chemical resistant.

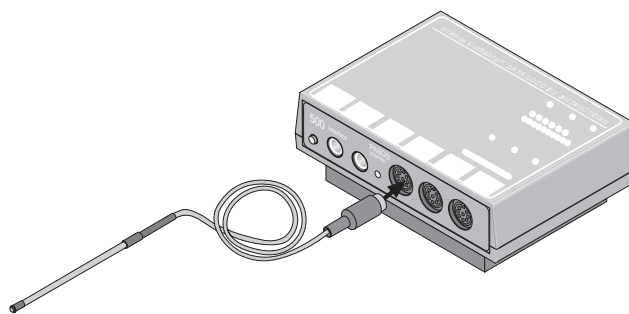

The sensor's operating range is from $-5\text{ }^{\circ}\text{C}$ to $105\text{ }^{\circ}\text{C}$. Do not use the sensor in a direct flame or on a hot plate.

Set up the sensor

- Plug the sensor's DIN plug into **Analog Channel A** on the interface.

Set up the sensor in the software

- In *DataStudio*, double-click the name of the sensor in the Sensors list in the Experiment Setup window. **Result:** The sensor's icon appears below Channel A of the interface. The sensor's parameter (e.g., Temperature) appears in the Data list.

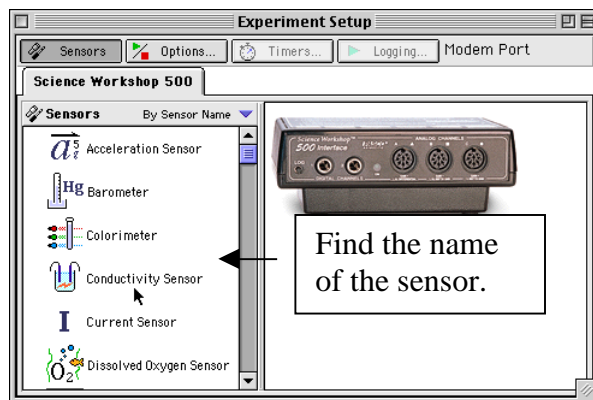

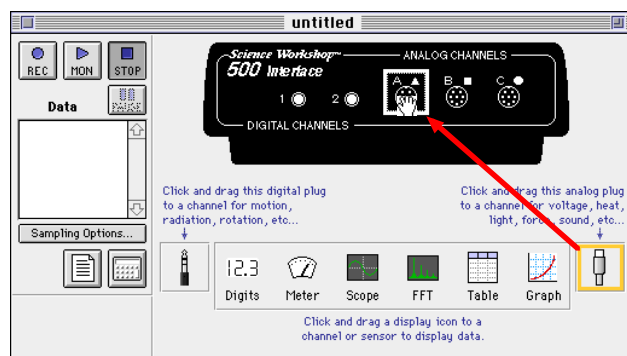

- In *ScienceWorkshop*, click-and-drag the 'analog sensor plug' icon to the Channel A icon in the Experiment Setup window, select the name of the sensor from the list of sensors and click 'OK' to return to the Experiment Setup window. **Result:** The sensor's icon appears below Channel A of the interface.



Set up a Graph display of Temperature versus Time

- In *DataStudio*, double-click the 'Graph' icon in the Displays list. **Result:** The Graph display automatically shows 'Temperature' versus 'Time'.
- In *ScienceWorkshop*, click-and-drag the 'Graph' display icon to the sensor's icon in the Experiment Setup window. Result: The Graph display automatically shows 'Temperature' versus 'Time'.



Start recording data

- In *DataStudio*, click the 'Start' button (). In *ScienceWorkshop*, click the 'REC' button ().
- Measure the temperature of your hand. Place the tip of the sensor in the palm of your hand and rub the sensor against your skin for several seconds. Note the temperature in the Graph display. Then move the tip of the sensor from the palm along one of your fingers to the end of the finger. Watch the change in temperature in the Graph display as you move the sensor.

Stop recording data

- Click 'Stop' to end data recording.

Rescale the Graph display

- In *DataStudio*, click the 'Scale-to-Fit' button () in the Graph display toolbar.
- In *ScienceWorkshop*, click the 'Autoscale' button () in the Graph tool palette.

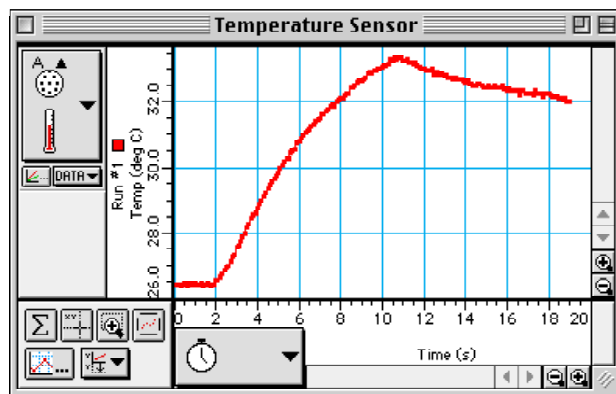
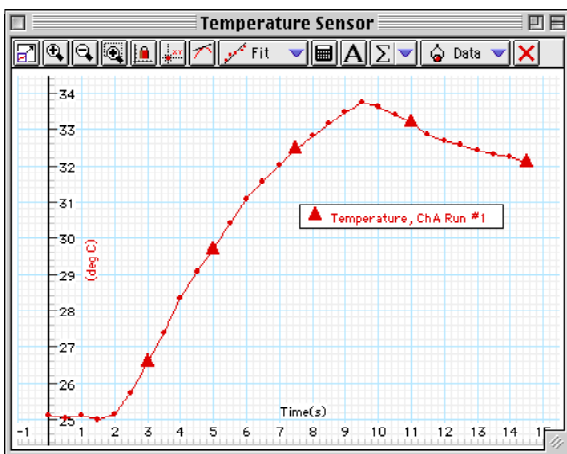

Remember to Use the Online Help

In *DataStudio*, click 'Contents' or 'Search...' in the Help menu to open the online help file. You can use the online help file to learn about any button, icon, menu, control, function or feature of the program.

In *ScienceWorkshop* for Macintosh, click 'Show Balloons' in the Help menu.

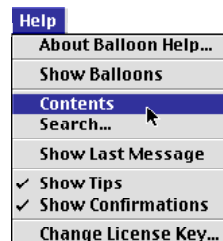
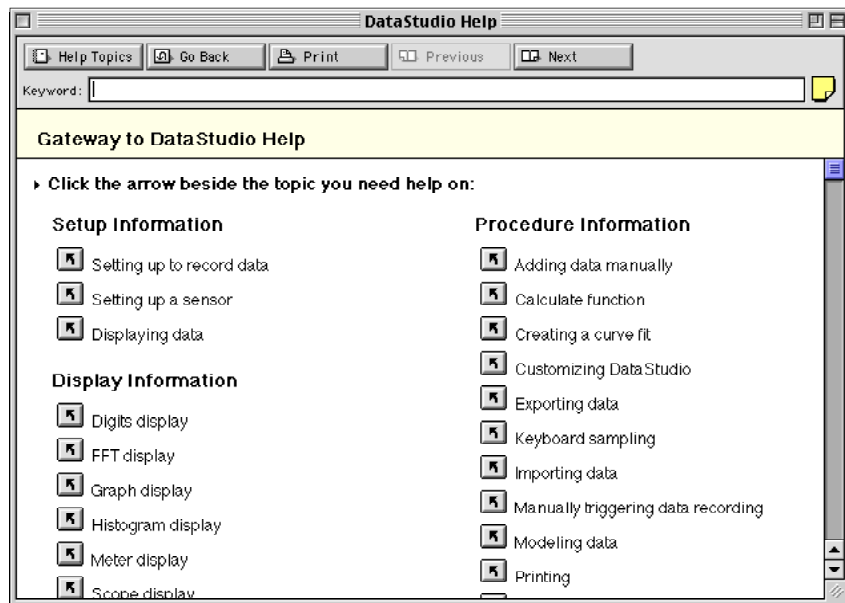

Memorandum – About Stewardship

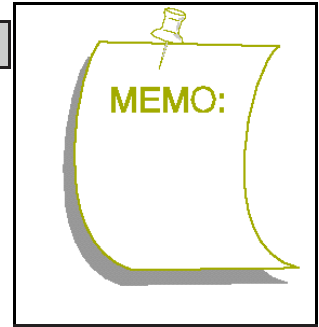

Greetings,

You are about to begin a journey of discovery about *Earth - The Water Planet*. The activities in this part of Earth Science Labs with Computers focus on the quality of the water around you. You will have the opportunity to make scientific measurements to determine the quality of water. You will also explore the relationships in nature that affect the quality of water.



Along the way you will learn about things that you can do to protect and even improve the quality of water. In other words, you will learn about *stewardship*.

Background

The water on our planet is essential to life as we know it. We use water for drinking, cleaning, recreation, manufacturing, and countless other purposes.

The quality of water can be altered by many factors: change in temperature, chemical pollutants, aquatic life-forms, etc.

The Water Planet

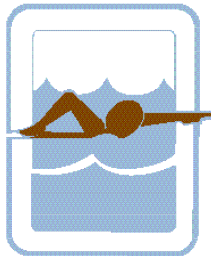
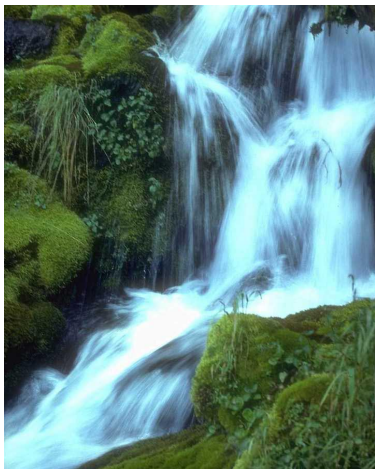

Activity Descriptions



Some of the activities in this part of Earth Science Labs with Computers are designed to be done out-of-doors. Other activities are best done in a lab or classroom. Some of the activities require water samples that you can collect and bring back to the classroom.

LAB = Activity for the lab or classroom

FIELD = Activity to be done out-of-doors

COLLECT = Activity using collected water samples

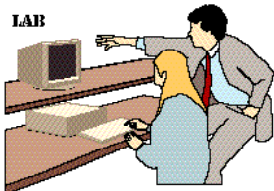
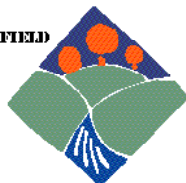

No.	List of Activities by Type	Type
S01 S04 S05 S06 S07	Streams and Rivers Clarity and Turbidity in Water Reducing Turbidity in Water pH of a Natural Water System Acid Rain: Detection and Causes	LAB 
S02 S03	Measure Stream Flow Temperature of Flowing Water	FIELD 
S04 S05 S06 S07	Clarity and Turbidity in Water Reducing Turbidity in Water pH of a Natural Water System Acid Rain: Detection and Causes (optional)	COLLECT 

Description

Each **LAB** activity in this part of Earth Science Labs with Computers has the same basic structure:

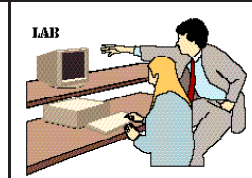

Equipment List	Purpose	Hypothesis
Background	Safety Reminders	Procedure Outline

The *Procedure Outline* includes the following parts:

Set Up the Equipment	Set Up the Experiment	Do the Experiment	Analyze the Data
----------------------	-----------------------	-------------------	------------------

Appendix A has more information about each part of the *Procedure Outline*.

Each **FIELD** activity involves making measurements and recording observations and data away from the classroom. You will use the “data logging” feature of the *ScienceWorkshop 500* Interface. Refer to *Appendix C* for more information about using the *ScienceWorkshop 500* Interface for data logging.



Each **COLLECT** activity starts with collecting samples. The rest of the activity is done in the lab or classroom using *DataStudio* or *ScienceWorkshop* and the interface.

Teacher's Notes – About Stewardship

Goal

The goal is to involve each student in hands-on activity and creative problem solving while they are learning fundamental science concepts and skills. They will make predictions, observe phenomena, record measurements, modify parameters, and draw conclusions. In other words, they will “do science”.



Teacher's Role

The teacher's role is “project manager”. Some activities call for you to be the transportation coordinator. However, most ‘in-the-field’ activities can also be done using an alternate method. In every activity, you will be the safety officer, the guide, and the resource person.

Activity Descriptions

The activities in the *Stewardship— The Water Planet* part of Earth Science Labs with Computers are similar to the tasks performed by scientists, water quality technicians, and environmental engineers around the world. All of the activities involve water quality. Some involve making measurements ‘in the field’. Others activities involve collecting samples and then testing the samples in the lab.

Teacher's Guide Description – Part 1

The pages in the Teacher's Guide for Part 1 are the same as the pages in the Student Workbook. However, the Teacher's Guide contains typical answers to the questions in the *Lab Report* section. The *Teacher's Notes* section includes time estimates, objectives, tips, and sample data.

Appendix A provides details for the procedure of each activity, such as how to calibrate a sensor, if needed. Appendix C describes how to use the *ScienceWorkshop 500* Interface for “data logging”.

The next page is a summary of preparation information for each activity in Part 1.



Preparation Information Summary

The following is a summary of information about each activity.

Teacher's Guide Preparation Summary — Part 1



**Stewardship:
The Water Planet**

- Type: Type of activity, C = Collect, F = Field, L = Lab
- Pre-lab: Does the activity require preparation before the day of the activity?
- Cal.: Calibration of sensor(s)
- Prep. Time: Estimate of preparation time on the day of the activity
- Act. Time: Estimate of activity time
- Other: Miscellaneous reminders

No.	Title	Type	Pre-lab	Cal.	Prep. Time	Act. Time	Other
S01	Streams and Rivers	L	organize clean-up	no	30 min	45 min	
S02	Measure Stream Flow	F	safety, transportation, review data logging	no	30 min	30 min	
S03	Temperature of Flowing Water	F	safety, transportation, review data logging	no	30 min	30 min	
S04	Clarity and Turbidity in Water	C, L	safety, transportation	yes	30 min	30 min	
S05	Reducing Turbidity in Water	C, L	safety, transporaton	yes	30 min	45 min	note 1
S06	pH of a Natural Water System	C, L	safety, transportation	yes	30 min	30 min	
S07	Acid Rain: Detection and Causes	L, C	safety	yes	2 hrs	30 min	

Notes

1. The water samples must be left undisturbed overnight.

Procedure Outline — Activity S01: Streams and Rivers



- This is a **LAB** activity.

Equipment	Qty	Consumables (*=optional)	Qty
Bucket, at least 8 L	1	Sand	10 kg
Container, 2 L	1	Water	10 L
Funnel, to fit inside tubing	1	Clay*	
Meter stick	1	Grass clippings*	
Protractor	1	Paper cup *	
Stream table	1	Pebbles*	
Tubing, 6 mm inside diameter	0.5 m	Potting soil*	
		Sticks*	

VOCABULARY	channel	course	delta	erosion	gradient
	meanders	precipitation	runoff	sediment	sedimentation

What Do You Think?

What things determine the overall shape of a river or stream? How does the **course** of a river or stream change over time? How does a river or stream form a **channel** or a **delta**?



Take time to answer the 'What Do You Think?' question(s) in the Lab Report section.

Background

Close your eyes. Imagine yourself sitting by a stream and or a river. Try to imagine the sights, smells, sounds, textures, etc. Now, using text and/or graphics, describe what you have imagined in the Report.

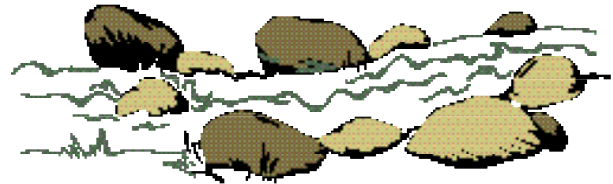

Stream Table

A stream table is a model of a stream or river. In normal operation, the stream table is placed on a horizontal surface. One end of the table is raised so the stream table is at a small angle relative to the horizontal surface. Material such as sand, clay, and soil is put into the stream table to simulate the ground. Water flows over the material in the stream table in much the same way as water in a stream or river flows naturally over the ground.

SAFETY REMINDERS

- Make sure the flow of water in the stream table is controlled.
- Turn off the flow of water when emptying the bucket.
- Dry any spilled water and avoid wet areas on the floor.

**THINK SAFETY
ACT SAFELY
BE SAFE!**

Procedure Outline

In this activity, use the stream table to observe how moving water makes a path in the ground to form a channel. Observe how the water deposits material to form a delta. Observe how the course of the moving water changes over time.

[✓] Remember, for more detailed information see **Appendix A**.



[] A. Set Up the Equipment

1. Dampen the sand. Arrange sand in the stream table so that the sand is level.
2. Set up the stream table so the stream table makes an angle of about 6° relative to horizontal.
3. Set up the water supply system.

[] B. Set Up the Experiment

4. Determine the percent grade (% grade) of the stream table. Record the angle of the table and the percent grade in the Report.

[] C. Do the Experiment

5. Trial 1	Normal conditions.	Pour water from the container into the funnel so water flows through the tubing onto the upper end of the stream table. Allow the water to flow gently onto the surface of the sand for five minutes. Observe what happens and record your observations.
6. Trial 2	Change the angle.	Repack the sand or use a fresh part of the stream table. Change the angle. Determine the percent grade (% grade) of the table. Record the angle and the percent grade as part of Trial 2 in the Report. Let water flow onto the sand for five minutes. Record your observations.
7. Trial 3	Reduced water flow	Repack the sand. Keep the angle of the stream table the same. Reduce the water flow. Let water flow slowly onto the sand for five minutes. Record your observations.
8. Trial 4	Artificial channel	Repack the sand. Put the stream table at a low angle. Record the angle with the protractor and record it in the Report. Carve an "S" shaped stream bed in the sand with your finger. Run the water down it for five minutes. Record your observations.
9. Trial 5	Level area	Repack the sand so there is a slope leading to a flat, level area near the base. As you run water down the slope, observe what happens when the water reaches the level area. Record your observations.
10. Trial 6	Different material	Repack your stream table with a mixture of moist sand, clay, and pebbles. Run the water down it for five minutes. Record your observations.

[] D. Analyze the Data

11. Examine the observations you have recorded in the Report to determine the relationship of the shape of a stream or river to natural factors such as the following:

steepness (angle) of slope	rate of water flow
shape of the existing ground material	type of ground material

Record your results in the Lab Report section.

Optional: Design a Stream Habitat

Habitat: A habitat is the place where an organism lives. It is made up of the surrounding vegetation, soils, and climate.

1. Discuss a stream habitat. Brainstorm all the parts of that habitat including climate, soil types, and surrounding vegetation. Make a design for a stream habitat. Put a sketch of your design in the Report.
2. Build a habitat in your stream table using the following materials:

clay	grass clippings	potting soil
pebbles	sand	sticks

3. Justify the decisions that were made for the design of your habitat. Write your justification in the Report.
4. Make a prediction of what will happen in your habitat with the addition of precipitation (rain). Include your prediction in the Report
5. Test your prediction by sprinkling your habitat with water from a cup with holes in it. Continue sprinkling for five minutes. Make observations during the process and record your observations in the Report. Share your results.

Lab Report — Activity S01: Streams and Rivers

Name _____

Class _____

Date _____

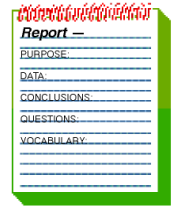

[] What Do You Think?

What things determine the overall shape of a river or stream? How does the **course** of a river or stream change over time? How does a river or stream form a **channel** or a **delta**?

*Answers will vary. Students may predict that the overall shape of a river or stream is changed most by the volume of water that flows. They may predict that the course of a river or stream becomes wider and the curves will become more sinuous over time. They may state that a river or stream forms a channel through **erosion** and a delta through **deposition**.*

Background

Imagine yourself sitting by a stream and or a river. Using text and/or graphics, describe what you imagined.

Answers will vary.

[] Do the Experiment

Trial 1: Normal Conditions	Angle = 6°	% grade = 10.5%
OBSERVATIONS	DIAGRAM	

Trial 2: Change the Angle	Angle = _____	% grade = _____
OBSERVATIONS	DIAGRAM	

- Describe the effect of the steepness of the slope on the shape of the stream bed:
Answers will vary. In general, the greater the slope of the stream table, the more rapidly the water will flow, and the more quickly the water will cut a deep stream bed.
- Describe the effect of the steepness of the slope on the solid materials carried by the water:
Answers will vary. In general, the more rapidly flowing water will be able to carry or move more solid material, and larger (heavier) pieces of material.

Trial 3: Reduce the Flow	Angle = _____
OBSERVATIONS	DIAGRAM

3. Describe the effect of changing the rate of water flow on the shape of the stream bed:
Answers will vary. In general, the slower flow rate should allow the stream bed to widen and form loops or meanders, but be less deep.
4. Describe the effect of changing the rate of water flow on the solid materials carried by the water:
The slower flow rate of the water means that less solid material can be moved or carried along the stream bed. Solid material that is moved from the top may be deposited before it is carried to the bottom.

Trial 4: Create an Artificial Channel	Angle = _____
OBSERVATIONS	DIAGRAM

5. As the water followed the “S” course you dug out , where was the sand deposited?
The sand appears to deposit in the parts of the “S” where the water slows down the most. The sand in the parts just below each curve is carried or moved the most.
6. On the diagram for Trial 4, use a solid line to trace the original “S” and a dotted line to trace the final course of the water.

Trial 5: Level Area	Angle = _____
OBSERVATIONS	DIAGRAM

- 7. What happened to the speed of the water when it reaches the level area?
The speed of the water slows down when it reaches the level area of the stream table.
- 8. What happened to the shape of the stream bed in the level area?
The shape of the stream bed became wider and less deep in the level area of the stream table.

Trial 6: Change the Material	Angle = _____
OBSERVATIONS	DIAGRAM

9. What happens to the flow of water in the mixture of sand, clay, and pebbles?

The flow of water carries the sand and most of the smaller pieces of clay, but is not fast enough to carry or move the pebbles and large pieces of clay.

[] Analyze the Data

- Examine the observations you have recorded in the Lab Report to determine the relationship of the shape of a stream or river to natural factors such as the following:

steepness (angle) of slope	rate of water flow
shape of the existing ground material	type of ground material

[] Conclusion

Answers will vary. One conclusion is that the steepness of the slope and the rate of water flow determine how much the stream bed changes shape as the water flows. The steeper the slope, the more material is moved or carried. The lower the rate of water flow, the less the stream bed changes over time.

[] Questions

1. Which natural factor seems to have the greatest effect on the shape of a stream or river?

Answers will vary (greatly). The natural factor that generally has the greatest effect on the CHANGE in shape of the stream is the slope of the terrain.

2. Which natural factor seems to have the smallest effect on the shape of a stream or river?

Answers will vary (greatly). The natural factor that generally has the smallest effect on the CHANGE in shape of the stream is the shape of the existing ground material.

Complete the following:

VOCABULARY

channel: The channel of a stream or river is the bed of the stream or river.

course: The course of a stream or river is the ground or path over which the stream or river moves.

delta: A delta is the usually triangular shaped deposit of material at the mouth of a stream or river.

erosion: Erosion is the transport of weathered material by wind, water, gravity, or ice.

gradient: The gradient of a stream is the slope or angle of the stream.

meanders: Meanders are turns, loops, or curves in the channel of a stream or river.

precipitation: Precipitation is water that falls as rain, hail, or snow.

runoff: Runoff is water, usually from precipitation, that does not soak into the ground.

sediment: Sediment is material that settles to the bottom of a liquid.

sedimentation: Sedimentation is the process of settling by which material in a liquid moves to the bottom.

Optional: Design a Stream Habitat

Habitat: A habitat is the place where an organism lives. It is made up of the surrounding vegetation, soils, and climate.

1. Put a sketch of your design for a stream habitat here.

Top View	Side View

2. Put your justification for the decisions that were made for the design of your habitat.

Answers will vary.

3. Put your prediction of what will happen in your habitat with the addition of precipitation (rain).

Answers will vary.

4. Record your observations of the test of your stream habitat.

OBSERVATIONS

Teacher's Notes – Activity S01: Streams and Rivers

Time Estimates	Preparation: 30 min	Activity: 45 min
-----------------------	----------------------------	-------------------------

Objectives

Students will be able to...

- set up and use a stream table
- observe and record the effect of the following factors on the flow of water over ground: angle, rate of water flow, pre-existing shape of the ground, and type of material
- describe the relationship between the individual factors and the flow of water

Notes

The greatest challenge in this activity is the mess involved. Sand and water get spilled. Books, papers, furniture, and people get wet. A formerly neat and tidy classroom starts to look like a natural disaster area. Students love it. Take good advantage of student energy by organizing clean-up teams *beforehand*.

If necessary, substitute a container that pours smoothly, such as a pitcher, for the funnel and tubing.

Stress the importance of observing *and* recording what happens before moving on to the next trial.

For the first trial, the stream table is at an angle of 6°, or a grade of about 10.5%.

Extensions

The optional stream habitat design activity allows students to experiment with more of the materials that are commonly found along a natural stream or river.

Stream Tables

Here are several scientific supply companies that provide stream tables:

Carolina Biological Supply Company 2700 York Road Burlington, NC 27215 USA tel. 800-334-5551 fax 800-222-7112 web www.carosci.com	Central Scientific Company (CENCO) 3300 CENCO Parkway Franklin Park, IL 60131 USA tel. 800-262-3626 fax 800-814-0607 web www.cenconet.com
Delta Education, Inc. 5 Hudson Park Drive, P.O. Box 915 Hudson, NH 03051-3989 USA tel. 603-889-8899 fax 603-880-6520 web www.delta-ed.com	Fisher Science Education 485 S. Frontage Road Burr Ridge, IL 60521 USA tel. 800-955-1177 fax 800-955-0740 web www.fisheredu.com

Procedure Outline — Activity S02: Measure Stream Flow Rate



- This is a **FIELD** activity that uses the 'data logging' feature of the interface.

Equipment	Qty	Per Student	Qty
ScienceWorkshop™ 500 Interface	1	Personal flotation device	1
Flow Rate Sensor (CI-6730)	1	Rubber boots (or waders)	1 pr
Metric Measuring Tape (SE-8712A)	1		
Waterproof tape	1 roll		

VOCABULARY	flow	flow rate

What Do You Think?

What is the relationship between the **depth** of water in a stream or river and the **rate** at which the water flows? What is the relationship between the **position** relative to the side of a stream or river and the flow of water? How does the flow of water in a **narrow section** of the stream or river compare to the flow in a **wider section**?



Take time to answer the 'What Do You Think?' question(s) in the Lab Report section.

Background

The flow of water in a stream or river depends on many factors. The steepness of the stream or river bed, the type of ground material over which the water flows, and the overall shape of the terrain are examples of factors that govern the flow of water. Another factor is the friction between the water and the banks of the stream or river.



You will use a Flow Rate Sensor to measure how fast water flows in a stream or river.

SAFETY REMINDERS

- Follow directions carefully when using the equipment for this activity.
- Wear a personal flotation device (life jacket).
- Wear clothing that is appropriate for this outdoor activity.

**THINK SAFETY
ACT SAFELY
BE SAFE!**

Procedure Outline

In this activity, use the Flow Rate Sensor to measure how fast water flows in a stream or river. Use the sensor to measure water flow at different depths in the stream or river. Then use the sensor to measure water flow at a constant depth, but at different distances from the shore. Finally, measure the water flow in a narrow section and then measure the water flow in a wider section.



[✓] Remember, for more detailed information see **Appendix A**.

[] A. Set Up the Equipment

1. Extend the Flow Rate Sensor to its full length.

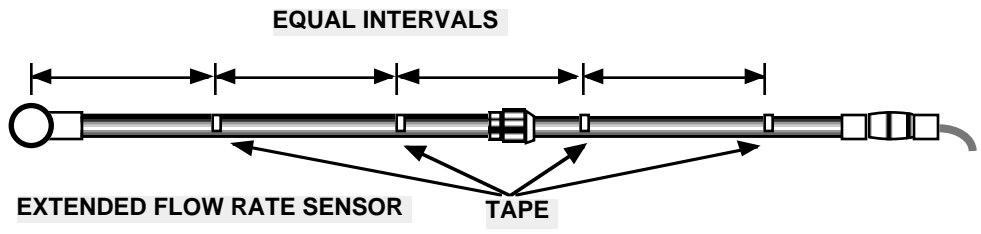

2. Use waterproof tape to put reference marks at equal intervals along the shaft of the Flow Rate Sensor.

[] B. Set Up the Experiment

You can use the *ScienceWorkshop 500* Interface to record data outside of a classroom. You can program the interface while it is connected to the computer, disconnect the interface and go collect data, and then re-connect the interface to the computer to analyze your data.

See Appendix C about how to use the *ScienceWorkshop 500* Interface for “data logging”

1. Start *DataStudio* or *ScienceWorkshop* and open the file as follows:

DataStudio	ScienceWorkshop (Mac)	ScienceWorkshop (Win)
S02 Stream Flow.DS	S02 Flow Rate	S02_FLOW.SWS

- The document opens with a Graph display.
2. In the program, prepare the interface to be disconnected for data logging.
 3. Disconnect the interface from the computer and power supply.
 4. Carry the interface and Flow Rate Sensor to the experiment site.

[] C. Do the Experiment

- For the first part of your data collecting, record the flow rate of the stream or river at three different depths at one position.
- For the second part of your data collecting, record the flow rate at a constant depth, but at three different positions relative to the shore or bank.
- In the final part of the data collecting, record the flow at a narrow section of the stream or river and then measure the flow at a wider section of the stream or river.

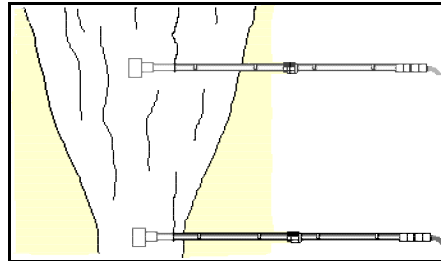
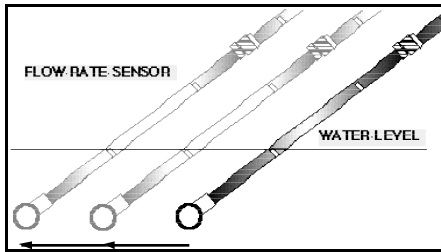
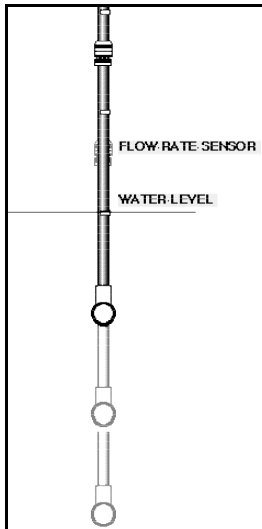

5. Connect the Flow Rate Sensor plug into Digital Channel 1 on the interface box.
6. Extend the Flow Rate Sensor and place the end in the water at the first depth. Hold onto the sensor with two hands.
7. When you are ready, press the LOG button on the front of the interface.

• Remember, the interface waits 10 seconds before it begins to record data.

8. Record data at the first location for about one minute. Press the LOG button again to stop recording data.
9. Repeat the data recording process for the other depths, different locations relative to the shore, and for the narrow and wide sections of the river or stream.

[] D. Analyze the Data

1. Reconnect the interface to the power supply and computer. Download the data from the interface to the computer. (*See Appendix C.*)
2. Examine each run of data in the Graph display to determine the relationship of the flow rate to depth, location relative to shore, and shape of the stream or river.
3. Write your conclusions and answer the questions in the Lab Report.

Record your results in the Lab Report section.

Lab Report — Activity S02: Measure Stream Flow Rate

Name _____

Class _____

Date _____

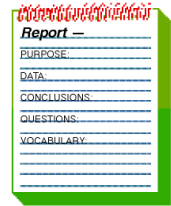

[] What Do You Think?

What is the relationship between the **depth** of water in a stream or river and the **rate** at which the water flows? What is the relationship between the **position** relative to the side of a stream or river and the flow of water? How does the flow of water in a **narrow section** of the stream or river compare to the flow in a **wider section**?

Answers will vary. Students may predict that the deeper the water, the slower the rate at which it flows. They may predict that the farther away from the edge of the stream, the faster the rate at which the water flows. They may state that a river or stream flows faster in a narrow section than it will in a wider section.

[] Analyze the Data

1. Use the Graph display to examine the *flow rate* versus *time* for each run of data.
2. Determine the average flow rate for each run of data and record the results in the Data Table.

Data Table

Trial #	Description	Results (Flow Rate)
1	Depth #1 (shallowest)	19.5 feet per second
2	Depth #2 (middle depth)	24.2
3	Depth #3 (deepest)	9.4
4	Location #1 relative to shore (closest)	1.4
5	Location #2 relative to shore	10.2
6	Location #3 relative to shore (farthest)	16.9
7	Narrow section of stream or river	24.6
8	Wider section of stream or river	12.1

- Be sure to include the units for the flow rate.
3. Explain the relationship of the flow rate to the depth, location from the shore, and width of the stream or river.

[] Conclusion

Answers will vary. One conclusion is that the flow of water decreases with depth, but increases as the distance from the shore increases.

[] Questions

1. What is the relationship of flow rate to depth?
Answers will vary. In general, as depth increases, the flow rate decreases. Why? Friction between the stream bed and the water slows the water near the bottom of the stream.
2. What is the relationship of flow rate to position relative to the shore of the stream or river?
Answers will vary. In general, flow rate increases as the distance from the shore increases. This is because friction between the water and the shore decreases farther from shore.
3. What is the relationship of flow rate to the width of the stream or river?
Answers will vary. Flow rate tends to be greater where the width of the stream is narrower. Why? One reason is that pressure upstream from the narrow section causes water to flow more rapidly through the narrow section.

Complete the following:

VOCABULARY

flow: A flow is a smooth, uninterrupted movement.

flow rate: Flow rate for water is the rate at which water flows, or moves, usually measured in volume (e.g., gallons per minute) or speed (e.g., meters per second).

Teacher's Notes – Activity S02: Measure Stream Flow Rate

Time Estimates	Preparation: 30 min	Activity: 30 min (plus travel time)
-----------------------	----------------------------	--

Objectives

Students will be able to...

- set up the *ScienceWorkshop* 500 Interface for “data logging”
- use the Flow Rate Sensor to measure flow rate
- observe and record the flow of water in a stream at different depths relative to the surface, at various positions relative to the shore, and in parts of the stream that have different width
- describe the relationship between the individual factors and the flow of water

Notes

This is a **FIELD** activity that uses the “data logging” feature of the *ScienceWorkshop* interface. Review Appendix C for information about data logging with the *ScienceWorkshop* 500 Interface.

Measurements

There are eight measurements recommended in the procedure outline for this activity. It may be possible for eight different teams of students to use the Flow Rate Sensor and *ScienceWorkshop* interface for data recording. A key to success is planning.

Safety

The premiere challenge in this activity is *safety*. The Flow Rate Sensor can be difficult to hold if used in swift water. Set up a “buddy system” with one student holding the sensor, a second student holding the “holder”, and a third student holding and operating the interface. Equally challenging is transportation to and from the stream or river. However, this activity generates great excitement because the students *do* the science (e.g., observing, making measurements, recording data).

Alternate Procedure

If necessary, substitute a swimming pool or pond for the flowing water. Have each group move with the Flow Rate Sensor at a constant speed along the edge of the pool or the shore of the pond. They should be able to measure a difference in flow rate at different depths and positions. They would not be able to measure the difference in flow rate due to width of the flowing water.

Extensions

Measure the rate of flow at different positions in a waterfall: near the top, at the edges, at the bottom.

DataStudio Sample Data

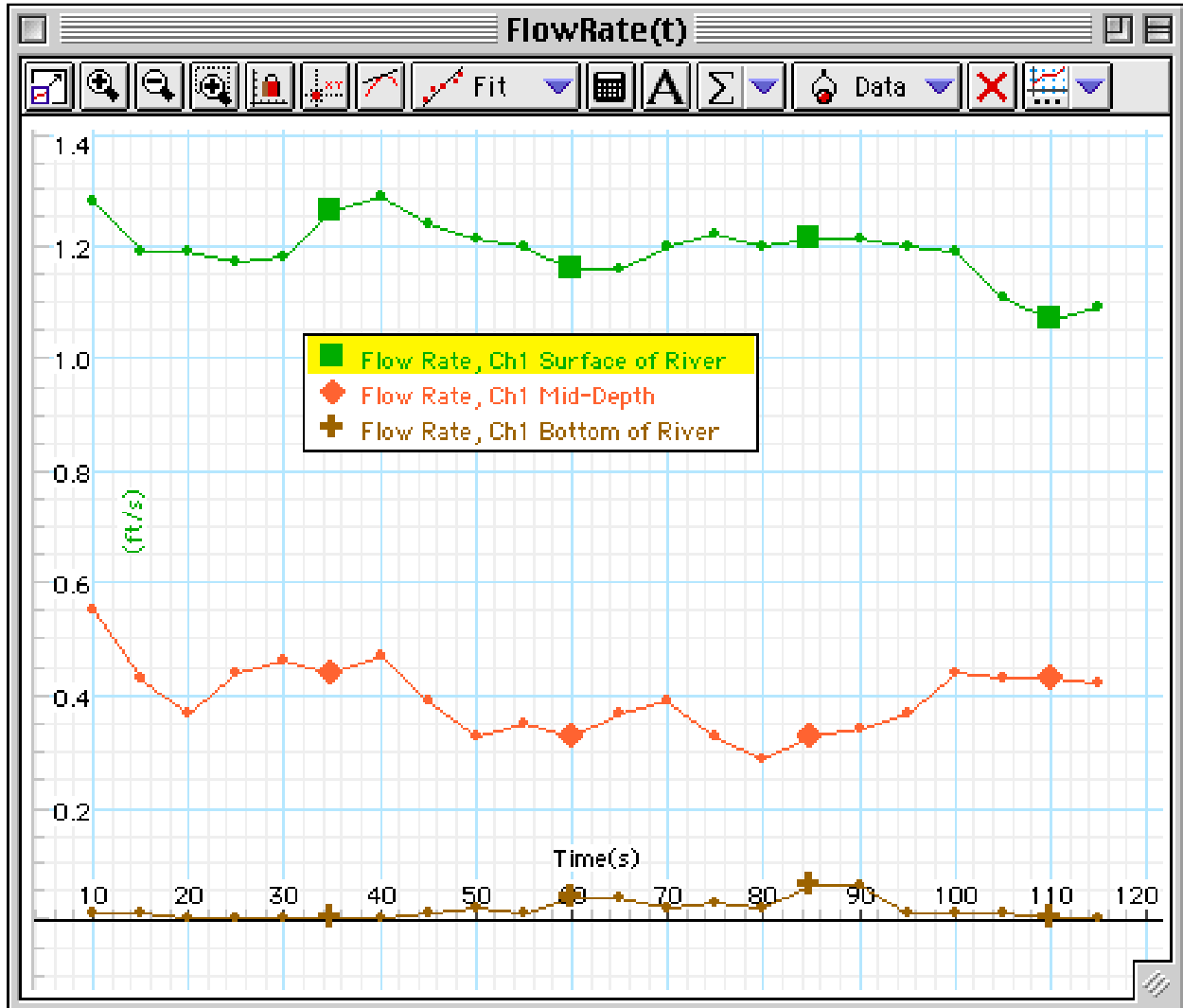

Procedure Outline — Activity S03: Temperature of Flowing Water



- This is a **FIELD** activity.

Equipment	Qty	Per Student	Qty
ScienceWorkshop™ 500 Interface	1	Personal flotation device	1
Temperature Sensor (CI-6505A)	1	Rubber boots (or waders)	1 pr
Metric Measuring Tape (SE-8712A)	1		
Marker pen	1		
Pole (approximately 2 m)	1		
Rubber band	2		
Sensor cable*, DIN-to-DIN	1		

(*included with the CI-6504A Light Sensor)

VOCABULARY	Celsius	temperature	thermal pollution
-------------------	---------	-------------	-------------------

What Do You Think?

What is the relationship between the **temperature** of water in a stream or river and the **depth** at which the temperature is measured? What is the relationship between the **temperature** and the **position** relative to the side of a stream or river? How does the temperature of the water in a **narrow section** of the stream or river compare to the temperature of the water in a **wider section**?



Take time to answer the 'What Do You Think?' question(s) in the Lab Report section.

Background

Temperature is the measure of the average kinetic energy of particles in a substance. A substance that is in motion has more kinetic energy than a substance that is at rest. One factor that may affect the temperature of water is the flow rate of the water.

You will use a Temperature Sensor to measure the temperature at different depths and locations in a stream or river.



SAFETY REMINDERS

- Follow directions carefully when using the equipment for this activity.
- Wear a personal flotation device (life jacket).
- Wear clothing that is appropriate for this outdoor activity.

**THINK SAFETY
ACT SAFELY
BE SAFE!**

Procedure Outline

In this activity, use the Temperature Sensor to measure the temperature of water in a stream or river. Use the sensor to measure temperature at different depths. Then use the sensor to measure temperature at a constant depth, but at different distances from the shore. Finally, measure the temperature in a narrow section and then measure the temperature in a wider section.



[✓] Remember, for more detailed information see **Appendix A**.

[] A. Set Up the Equipment

1. Use rubber bands to fasten the Temperature Sensor to one end of a 2 m pole. Attach the DIN-to-DIN sensor cable to the end of the Temperature Sensor's cable.

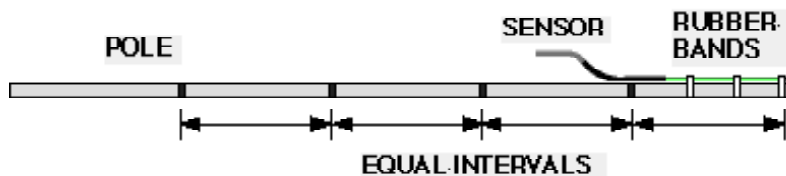

2. Use a marker pen to put reference marks at equal intervals along the pole.

[] B. Set Up the Equipment

You can use the *ScienceWorkshop 500* Interface to record data outside of a classroom. You can program the interface while it is connected to the computer, disconnect the interface and go collect data, and then re-connect the interface to the computer to analyze your data.

See **Appendix C** about how to use the *ScienceWorkshop 500* Interface for “data logging”

1. Start *DataStudio* or *ScienceWorkshop* and open the file as follows:

DataStudio	ScienceWorkshop (Mac)	ScienceWorkshop (Win)
S03 Stream Temp.DS	S03 Temperature Flow	S03_TEMP.SWS

- The file opens with a Graph display.
2. In the program, prepare the interface to be disconnected for data logging.
 3. Disconnect the interface from the computer and power supply.
 4. Carry the interface and Temperature Sensor to the experiment site.

[] C. Do the Experiment

- For the first part of your data collecting, record the temperature of the stream or river at three different depths at one position.
- For the second part of your data collecting, record the temperature at a constant depth, but at three different positions relative to the shore or bank.
- In the final part of the data collecting, record the temperature at a narrow section of the stream or river and then measure the temperature at a wider section of the stream or river.

When you put the Temperature Sensor into the water, don't go beyond the Temperature Sensor's DIN plug.

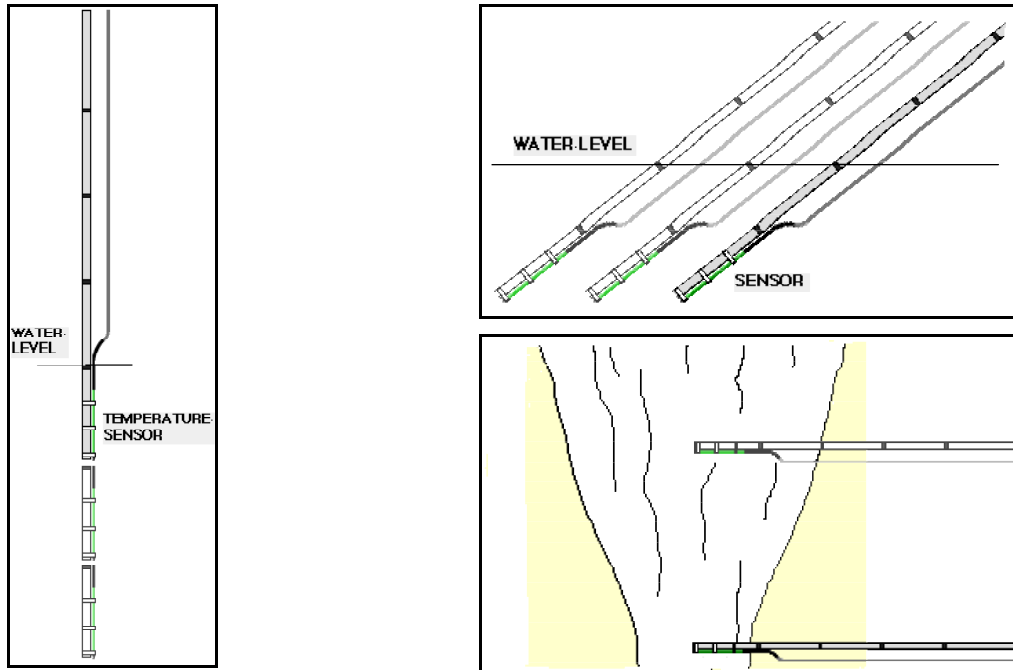

1. Connect the sensor into Analog Channel A on the interface box.
2. Place the end of the sensor in the water at the first depth.
3. When you are ready, press the LOG button on the front of the interface.

• Remember, the interface waits 10 seconds before it begins to record data.

4. Record data at the first location for about one minute. Press the LOG button again to stop recording data.
5. Repeat the data recording process for the other depths, different locations relative to the shore, and for the narrow and wide sections of the river or stream.

[] D. Analyze the Data

1. Reconnect the interface to the power supply and computer. In the program, download the data from the interface to the computer. (*See Appendix C.*)
2. Examine each run of data in the Graph display to determine the relationship of the temperature to depth, location relative to shore, and width of the stream or river.
3. Write your conclusions and answer the questions in the Report.

Record your results in the Lab Report section.

Lab Report — Activity S03: Temperature of Flowing Water

Name _____

Class _____

Date _____

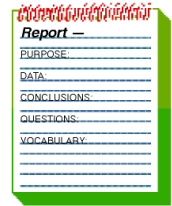

[] What Do You Think?

What is the relationship between the **temperature** of water in a stream or river and the **depth** at which the temperature is measured? What is the relationship between the **temperature** and the **position** relative to the side of a stream or river? How does the temperature of the water in a **narrow section** of the stream or river compare to the temperature of the water in a **wider section**?

Answers will vary. Students may predict that the deeper the water, the colder the temperature of the water. They may predict that the farther away from the edge of the stream, the colder the temperature of the water. They may state that a river or stream is colder in a narrow section than it will in a wider section.

[] Analyze the Data

1. Use the Graph display to examine the *temperature* versus *time* for each run of data.
2. Determine the average temperature for each run of data and record the results in the Data Table.

Data Table

Trial #	Description	Results (Temperature)
1	Depth #1	
2	Depth #2	
3	Depth #3	
4	Location #1 relative to shore	
5	Location #2 relative to shore	
6	Location #3 relative to shore	
7	Narrow section of stream or river	
8	Wider section of stream or river	

- Be sure to include the units for the flow rate.
3. Explain the relationship of the temperature to the depth, location from the shore, and width of the stream or river.

[] Conclusion

Answers will vary. One conclusion is that the temperature of water decreases with depth, and also decreases as the distance from the shore increases.

[] Questions

1. What is the relationship of temperature in flowing water to depth?
Answers will vary. In general, as depth increases, the temperature decreases. Why? Water at the surface receives more sunlight energy and is warmed slightly.
2. What is the relationship of temperature to position relative to the shore of the stream or river?
Answers will vary. In general, temperature decreases as the distance from the shore increases. Why? Water nearer the shore absorbs some energy from the ground.
3. What is the relationship of temperature to the width of the stream or river?
Answers will vary. Temperature may change with width, but our data are inconclusive.

Complete the following:

VOCABULARY

Celsius: The Celsius scale of temperature measurement is a thermometer scale in which the interval between the freezing point and boiling point of water is divided into 100 degrees, where 0 degrees Celsius ($^{\circ}\text{C}$) is freezing and 100 degrees Celsius ($^{\circ}\text{C}$) is boiling.

temperature: Temperature is the measurement of the average kinetic energy of the particles in a substance. Temperature is also the level of hotness or coldness of a substance.

thermal pollution: Thermal pollution is the discharge of liquid into a natural body of water at such a high temperature that aquatic life in the water is harmed.

Teacher's Notes – Activity S03: Temperature of Flowing Water

Time Estimates	Preparation: 30 min	Activity: 30 min (plus travel time)
-----------------------	----------------------------	--

Objectives

Students will be able to...

- set up the *ScienceWorkshop* 500 Interface for “data logging”
- use the Temperature Sensor to measure temperatures
- observe and record the temperature of water in a stream at different depths relative to the surface, at various positions relative to the shore, and in parts of the stream that have different width
- describe the relationship between the individual factors and the temperature of water

Notes

This is a **FIELD** activity that uses the “data logging” feature of the *ScienceWorkshop* interface. Review Appendix C for information about data logging with the *ScienceWorkshop* 500 Interface.

Safety

The premiere challenge in this activity is *safety*. Set up a “buddy system” with one student holding the pole with the sensor, a second student holding the “holder”, and a third student holding and operating the interface. Equally challenging is transportation to and from the stream or river. However, this activity generates great excitement because the students *do* the science (e.g., observing, making measurements, recording data).

Data Recording

There are eight measurements recommended in the procedure outline for this activity. It may be possible for eight different teams of students to use the Temperature Sensor and *ScienceWorkshop* interface for data recording. As with the activity to measure flow rate, a key to success is planning.

Alternate Procedure

If necessary, substitute a swimming pool or pond for the flowing water. Have each group move with the Temperature Sensor at a constant speed along the edge of the pool or the shore of the pond. They should be able to measure a difference in temperature at different depths and positions. They would not be able to measure the difference in temperature due to width of the flowing water.

Extensions

Measure the temperature at different positions in a waterfall: near the top, at the edges, at the bottom.

Measure the temperature at different positions in a body of water that is still, or flowing very slowly. Compare the results to the temperatures measured in a faster moving body of water.

DataStudio Sample Data

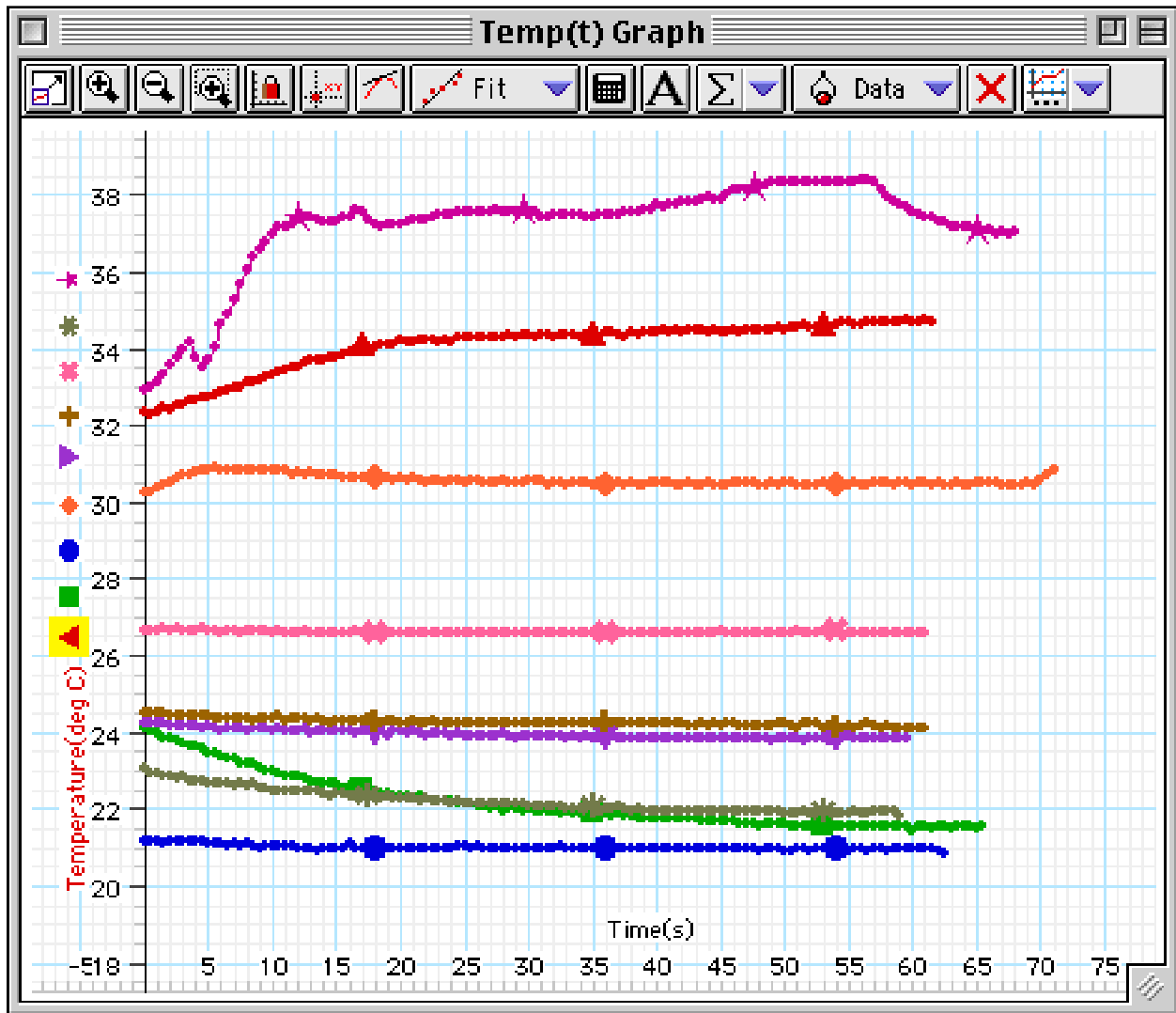

Procedure Outline — Activity S04: Clarity and Turbidity in Water



- This activity has two parts: a **COLLECT** part and a **LAB** part.

Equipment Needed	Qty	Equipment Needed	Qty
Light Sensor (CI-6504A)	1	Ruler, metric	1
Base & Support Rod (ME-9355)	1	Secchi disk symbol	1
Beaker, 1000 mL	2	Per Student	Qty
Bottle, square, clear, ~125 mL	1	Personal flotation device	1
Clamp, Buret (SE-9446)	2	Rubber boots (or waders)	1 pr
Clamp, Multi (SE-9442)	1	Consumables	Qty
Container, ~ 3 L	1	Cardboard box, ~15 by 15 by 12 cm	1
Graduated cylinder, 100 mL	2	<i>Dirt (optional)</i>	100 g
Light source, DC (e.g., pen light)	1	Label	1
Marking pen	1	Tape	1 roll
Rod, Lab Stand, 45 cm (ME-8736)	1	Water	2 L

VOCABULARY	clarity	erosion	suspension	turbidity
-------------------	---------	---------	------------	-----------

What Do You Think?

What is the relationship between the clarity and turbidity of water in a natural system?



Take time to answer the 'What Do You Think?' question(s) in the Lab Report section.

Background

As the number of particles of solid matter (e.g., dirt) suspended in water increases, less light can pass through it. **Turbidity** is a measure of how deep you can see an object below the surface of the water. **Clarity** is a measure of how much light passes through a certain amount of water.

Reduced light penetration through water can have several consequences. When less light penetrates, aquatic plant growth will be limited.

Fewer aquatic plants mean less photosynthesis and therefore less oxygen in the water. This affects the fish and other organisms that feed on plants and rely upon the oxygen given off by the plants. A second consequence of extra material suspended in water is that the material absorbs heat from the sun and increases the water temperature. This also decreases the amount of oxygen that is in the water. Causes of turbidity are algae and inorganic material from soil erosion.

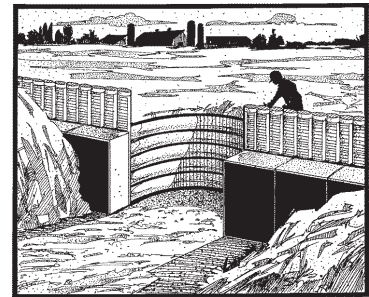

SAFETY REMINDERS (COLLECT)

- Follow directions carefully when using the equipment for this activity.
- Wear a personal flotation device (life jacket).
- Wear clothing that is appropriate for this outdoor activity.

**THINK SAFETY
ACT SAFELY
BE SAFE!**

Procedure Outline

You will collect water from a river or stream. In the lab part, you will use a Secchi disk symbol to measure the turbidity of the water and then you will use a Light Sensor and light source to measure the clarity of the water.



[✓] Remember, for more detailed information see **Appendix A**.

In this activity, collect (or make) a sample of dirty water to test. In the lab, use a *Secchi disk symbol* and graduated cylinder to measure the *turbidity* of the water. Calibrate the Light Sensor and then use the Light Sensor to measure the *clarity* of the water. Finally, compare the turbidity of the water to the clarity of the water.

[] **Pre-Lab: Collect the Sample**

- Use a container to collect about 2 liters of non-clear water from a river, lake or pond. Put a label on the container and mark the label with the location of the water source.

(Alternate Procedure: Add a small amount of dirt to 2 liters of water and shake vigorously to thoroughly mix the dirt and water.)

[] **A. Set Up the Equipment**

Equipment Setup for Turbidity

A Secchi disk is a circular disk, 20 cm (0.20 m) in diameter, that is divided into four quarters. The quarters are alternately painted black and white. A cord or chain is attached to the disk so the disk can be lowered vertically into the water. The cord or chain is calibrated in equal intervals so the depth can be measured.

You will use a Secchi disk *symbol* instead of a Secchi disk.

1. Place the Secchi disk symbol on a flat surface.
2. Place a graduated cylinder on the center of the disk.

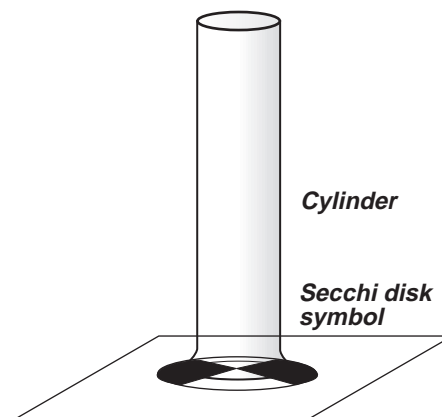

Equipment Setup for Clarity

1. Use a base and support rod, a lab stand rod, a multi-clamp (right-angle clamp), and two buret clamps to make a stand for the pen light and Light Sensor.
2. Adjust the position of the pen light and the Light Sensor so the square bottle just fits between them. Line up the pen light and the sensor so the light goes in a straight line through the bottle to the sensor.

Put strips of tape on the table to trace the position of the square bottle.

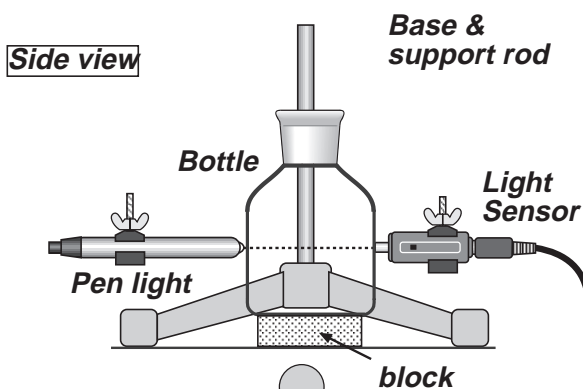

Other equipment setups can be used.

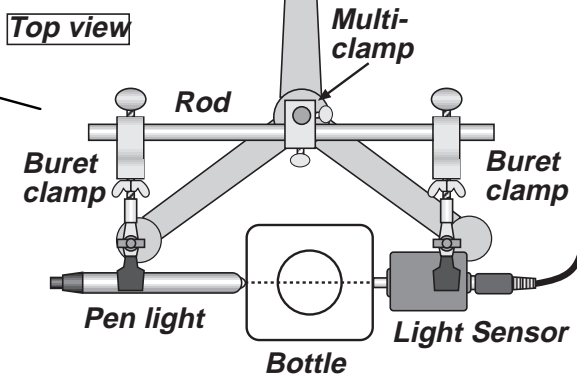

- Use a cardboard box to make a "light shield" that can fit over the pen light, square bottle, and sensor.

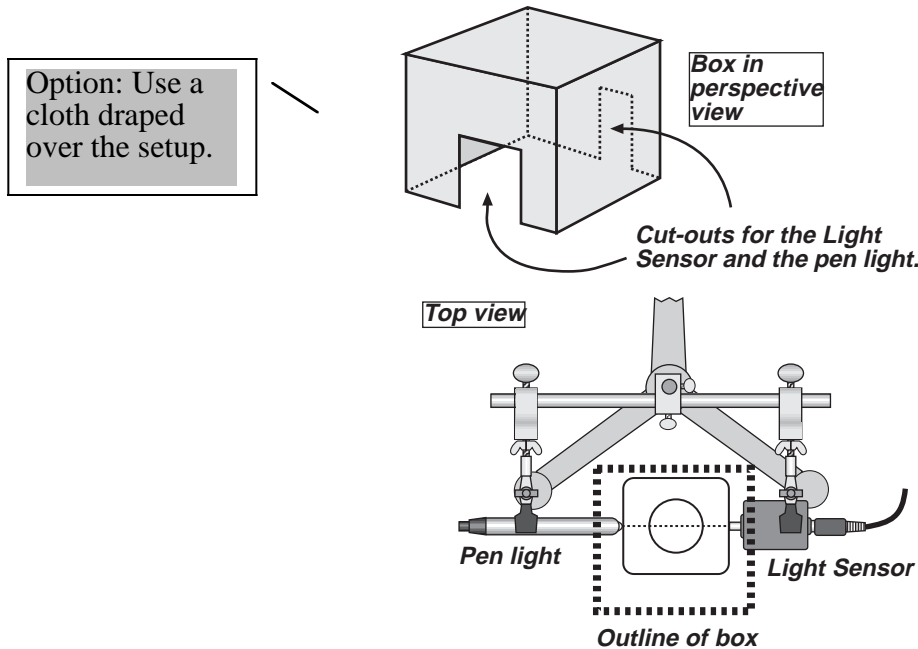

[] B. Set Up the Experiment

Computer Setup

- Connect the sensor into Analog Channel A on the *ScienceWorkshop* interface.
- Open the file titled as shown:

DataStudio	ScienceWorkshop (Mac)	ScienceWorkshop (Win)
S04 Clarity.ds	S04 Clarity	S04_CLAR.SWS

- The *DataStudio* file has a Workbook display. Read the instructions in the Workbook. The *ScienceWorkshop* file has a Table display. Data recording is preset to stop at 60 seconds.

Sensor Calibration

- Calibrate the Light Sensor using the pen light. Put clear water in the square bottle. Let the light transmitted through the clear water be "100% intensity".

[✓] Remember, for more detailed information see *Appendix A*.

[] C. Do the Experiment

- For the first part of your data collecting, measure the turbidity of the water sample.
- For the second part of your data collecting, use the Light Sensor and pen light to measure the clarity of the water.

Data Recording Part 1: Turbidity

1. Put about 800 mL of your water sample in a beaker.
2. Look down through the graduated cylinder at the Secchi disk symbol. Slowly pour some of the water from the beaker into the cylinder. Keep looking at the Secchi disk symbol as you pour the water.

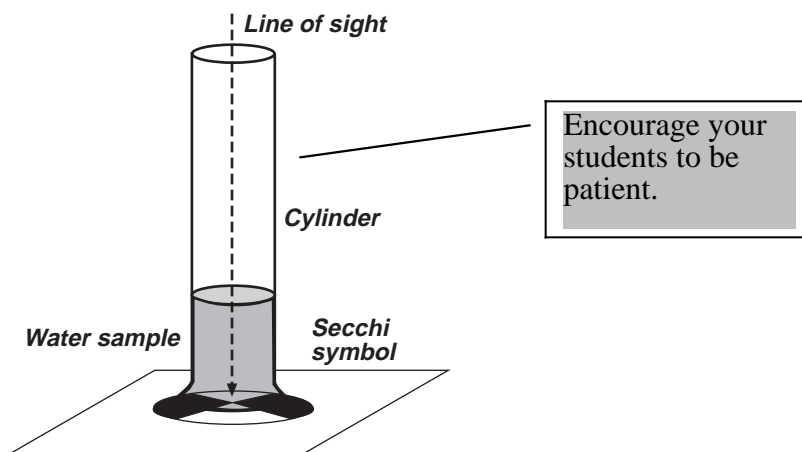

3. When you can barely see the symbol through the water, *stop* for a moment. Let the water become still. If you can see any of the symbol through the water, slowly pour more water into the cylinder until you can't see the Secchi disk symbol any more.
4. Record the depth of the water at which you could no longer see the Secchi disk symbol.

Put you data in the Lab Report section.

Data Recording Part 2: Clarity

1. Pour 100 mL of your water sample from the beaker into the square bottle. Turn on the pen light. Place the square bottle exactly between the Light Sensor and the pen light. Cover the sensor, bottle, and light with the cardboard box "light shield".
2. Start recording data. After data recording stops automatically, remove the box and the bottle, but leave the pen light "on". Empty and clean the square bottle.

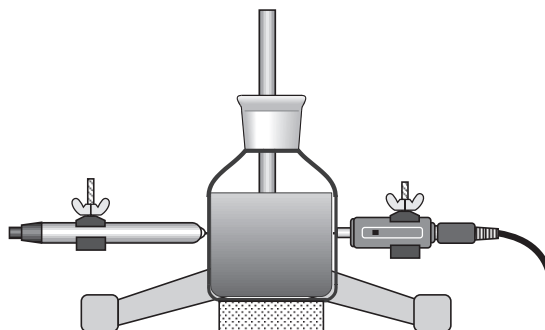

Data Recording Part 2 (continued)

Repeat the data recording process two more times.

3. Make a second water sample by putting 50 mL of your original water sample into a clean graduated cylinder. Add 50 mL of clear water. Pour sample #2 into a clean beaker and mix thoroughly. Clean the graduated cylinder. Measure the turbidity and clarity of this second water sample. After measuring, clean the beaker, cylinder, and square bottle.

Remember: Measure the *turbidity* using the Secchi disk symbol. Measure the *clarity* using the Light Sensor and the pen light.

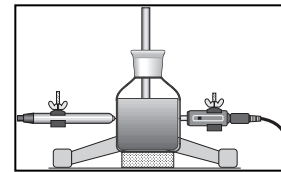
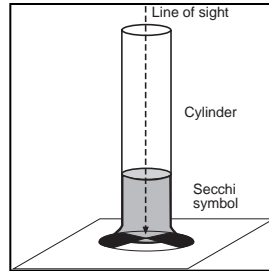

Note: The second water sample is diluted 1: 1:1 (50%).

4. Make a third water sample by putting 33 mL of your original water sample into a clean graduated cylinder. Add 67 mL of clear water. Repeat the data recording process.

Note: The third water sample is diluted 1:2 (33%).

[] D. Analyze the Data

1. Use the Table display to examine each run of data.

Hint: Drag data runs to the Table display in *DataStudio* to add data runs to the Table. Use the 'Add Column' menu in *ScienceWorkshop* to add data runs to the Table.

2. Determine the average intensity of light that was transmitted through each sample of water. Record the average intensity of light for each sample.
3. Write your conclusions and answers in the Lab Report.

Record your results in the Lab Report section.

Lab Report — Activity S04: Clarity and Turbidity in Water

Name _____

Class _____

Date _____

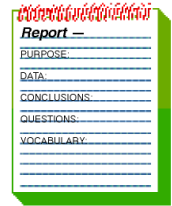

[] What Do You Think?

What is the relationship between the clarity and turbidity of water in a natural system?

Answers will vary. Students may predict that the clarity of water is dependent on the turbidity of the water, and that the clarity increases as the turbidity decreases.

[] Analyze the Data

1. Use the Table display to determine the *mean* of the light intensity (% max) for each sample of water you tested.
2. Record the light intensity (% max) for each sample of water.

Data Table

Sample	Turbidity (depth of water in cm)	Clarity (% max of light intensity)
1 (undiluted)	2.0	17.0
2 (1:1)	5.1	67.2
3 (1:2)	10.5	88.2

[] Conclusion

1. How does your hypothesis (answer to “What Do You Think?”) compare with the results?
Answers will vary. One conclusion is that the clarity of water is dependent on the turbidity of the water, and that the clarity increases as the turbidity decreases.

[] Questions

1. Why is it important that sunlight be able to be transmitted through the water?
It is important that sunlight can be transmitted through water because aquatic plant life depends on sunlight for the energy used during photosynthesis. The less light, the less photosynthesis, and the slower the plant grows. If plant life decreases, other aquatic life may decrease as well.
2. What might improve the clarity of the water in a natural system?
Answers will vary. One of the things that can improve the clarity of water in a natural system is an abundance of vegetation on the watershed to limit runoff.

3. Predict how the turbidity of water in a natural system might be different at different times of the year. Explain your reasoning.

The turbidity of the water may vary at different times of the year due to the changes in weather with the seasons. During the rainy season, more runoff may flow into the stream and increase the turbidity.

Optional: If you collected your water from a natural source, describe your field site: Do streams, ditches, or drains feed into your site? Is there new construction or bare soil that might easily erode? What features might contribute to the turbidity?

Complete the following:

VOCABULARY

clarity: Clarity is a measure of how clear something is, or a measure of how much light can be transmitted through the substance.
erosion: Erosion is the movement of weathered material by wind, water, gravity, and ice.
suspension: The state of a substance when its particles are mixed with but undissolved in a liquid.
turbidity: Turbidity is the cloudiness of water resulting from suspended material in the water. Turbidity is also a unit of measurement quantifying the degree to which light traveling through water is scattered by suspended material.

Teacher's Notes – Activity S04: Clarity and Turbidity in Water

Time Estimates	Preparation: 30 min	Activity: 30 min (plus travel time)
-----------------------	----------------------------	--

Objectives

Students will be able to...

- use a Secchi disk symbol and graduated cylinder to measure the turbidity of water
- use the Light Sensor to measure the relative intensity of light transmitted through a sample of water
- describe the relationship between the clarity and turbidity of water

Notes

If it is not possible to collect a water sample, make muddy water by adding a small amount of dirt to several liters of water.

Safety

The premiere challenge in the **COLLECT** part of this activity is SAFETY. Equally challenging is transportation to and from the water source.

Setup

A pen light works well as a light source because the bulb is small and it is easy to line up the bulb with the opening of the Light Sensor. If you do not have a penlight, it may be possible to use a small “Mag Lite”-type flashlight. Remove the lens holder and lens to expose the small bulb.

The Light Sensor and penlight must be carefully aligned for an accurate measurement of clarity. The diagrams for this activity show one way that the sensor and light source can be mounted using clamps, a rod, and a base and support rod.

Use the cardboard box or a dark-colored cloth as a light shield to keep the sensor from being saturated by ambient light.

Data Recording

There are two different measurements recommended in the activity: one measurement of turbidity (the depth of water in the graduated cylinder at which the Secchi disk symbol is no longer visible), and one measurement of clarity (the relative intensity of the light that travels through a sample of water).

Analyze the Data

Water that obscures the view of the Secchi disk symbol at a depth of only a few milliliters is very low in clarity while water that allows you to still see the Secchi symbol when the cylinder is almost full has much higher clarity.

Extensions

Measure the clarity and turbidity of common household liquids or popular soft drinks using the procedure described above.

DataStudio Sample Data

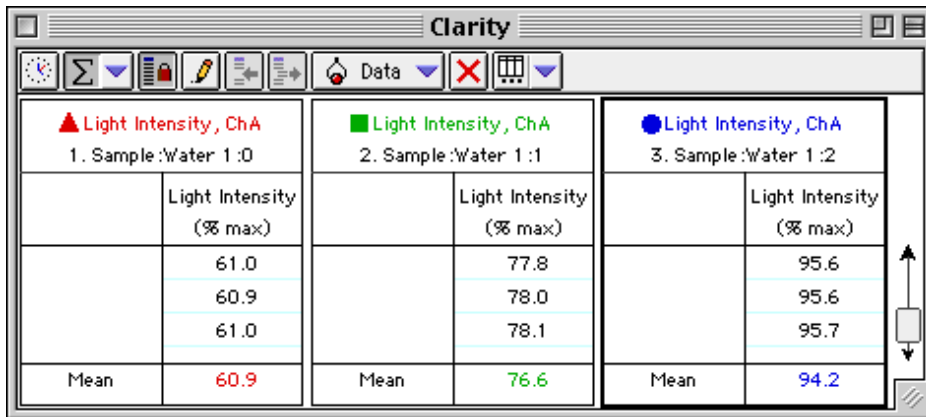

The screenshot shows a software window titled "Clarity" with three data tables. Each table has a header row with a colored triangle icon and a title, and a data table below it. The first table is red, the second is green, and the third is blue. Each data table has two columns: "Light Intensity (% max)" and "Mean".

▲ Light Intensity, ChA 1. Sample:Water 1:0	
Light Intensity (% max)	
61.0	
60.9	
61.0	
Mean	60.9

■ Light Intensity, ChA 2. Sample:Water 1:1	
Light Intensity (% max)	
77.8	
78.0	
78.1	
Mean	76.6

● Light Intensity, ChA 3. Sample:Water 1:2	
Light Intensity (% max)	
95.6	
95.6	
95.7	
Mean	94.2

Secchi Disk Symbol

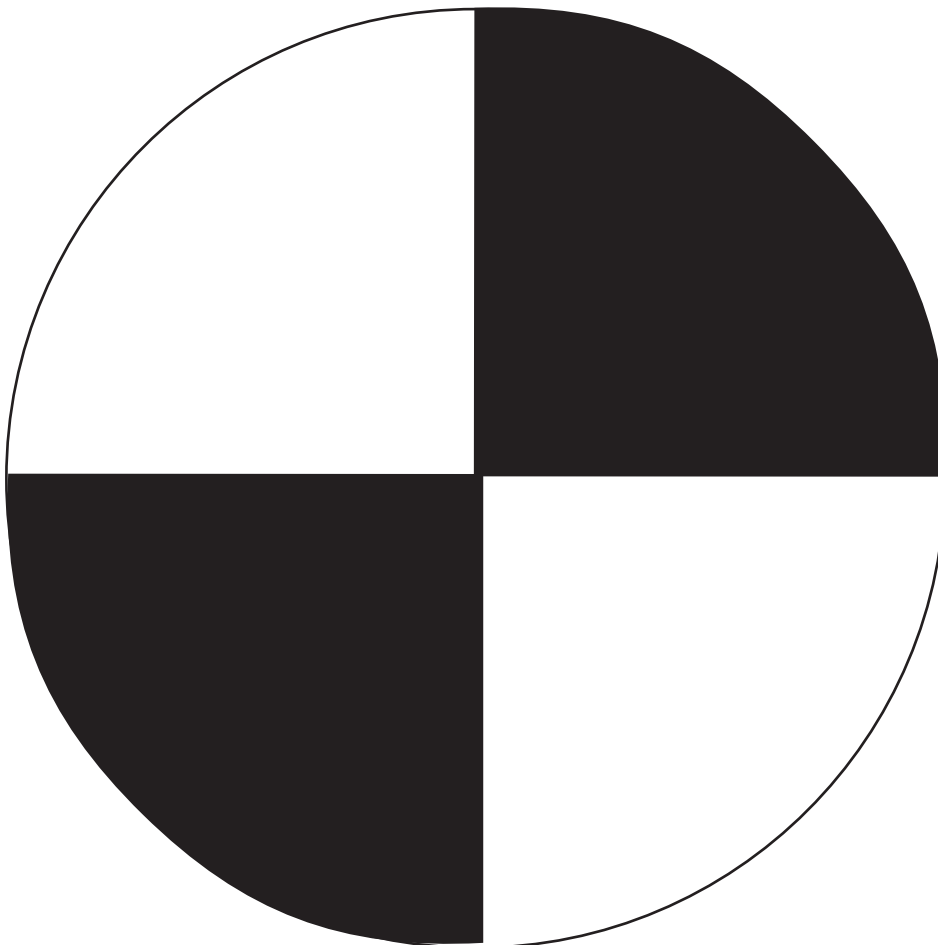

Procedure Outline — Activity S05: Reducing Turbidity in Water



- This activity has two parts: a **COLLECT** part and a **LAB** part.

Equipment Needed	Qty	Per Student	Qty
Light Sensor (CI-6504A)	1	Personal flotation device	1
Balance, Triple Beam (SE-8723)	1	Rubber boots (or waders)	1 pr
Base & Support Rod (ME-9355)	1	Protective gear	1 set
Bottle, square, clear, ~500 mL	3		
Clamp, Buret (SE-9446)	2	Chemicals and Consumables	Qty
Clamp, Multi (SE-9442)	1	Aluminum sulfate (Al₂(SO₄)₃)	5 g
Container, ~ 3 L	1	Calcium oxide (CaO)	2.5 g
Graduated cylinder, 100 mL	1	Iron (II) chloride (FeCl₂)	2.5 g
Light source, DC (e.g., pen light)	1	Cardboard box, ~15 by 15 by 12 cm	1
Knife	1	Label	3
Marking pen	1	Water (muddy)	2 L
Rod, Lab Stand, 45 cm (ME-8736)	1	Weighing paper	3

VOCABULARY	floc	flocculation	gelatinous	sedimentation
-------------------	------	--------------	------------	---------------

What Do You Think?

How does the rate of reducing turbidity in water by sedimentation (allowing suspended matter to settle) compare to the rate of reducing turbidity by flocculation (using chemicals to remove suspended matter)?



Take time to answer the 'What Do You Think?' question(s) in the Lab Report section.

Background

One of the first steps in making water safe to drink is to remove any suspended matter from the water. Because much of the suspended matter in water settles to the bottom if allowed to set undisturbed, a water treatment plant puts water in holding areas for several hours. Some of the suspended matter sinks to the bottom, leaving the top portion of water less turbid. This process is **sedimentation**.

Smaller particles of suspended matter may not settle to the bottom no matter how much time the water sets undisturbed. In order to remove these smaller particles, water treatment plants use a process called **flocculation**. Chemical such as aluminum sulfate (“alum”) or a mixture of calcium oxide (“lime”) and iron chloride are added to the water. These chemicals form fluffy, gelatinous solids called floc. As the floc forms it gets larger and heavier and sinks to the bottom.

As floc drifts downward, the smaller particles of suspended matter clings to it. Once the floc arrives at the bottom, the top portion of the water is less turbid. Both processes may be used to remove suspended matter from water. Neither process harms the water.

You will collect some muddy, turbid water. You will measure how fast sedimentation makes the muddy water become clearer compared to how fast flocculation makes the muddy water become clearer.

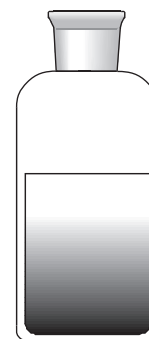

SAFETY REMINDERS (COLLECT)

- Wear a personal flotation device (life jacket) when collecting water samples for this activity.
- Wear clothing that is appropriate for the outdoor part of this activity.

SAFETY REMINDERS (LAB)

- Wear protective gear while handling chemicals.
- Follow directions for using the equipment.
- Dispose of all chemicals and solutions properly.



Procedure Outline

In this activity, use the Light Sensor to measure the clarity of the water samples. You will let one container set undisturbed so the rate of reducing turbidity by sedimentation can be measured. You will add aluminum sulfate to a second container, and a mixture of calcium oxide and iron chloride to the third container in order to measure the clarity due to flocculation.

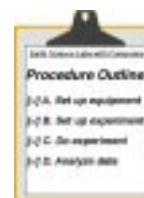

[✓] Remember, for more detailed information see **Appendix A**.

[] **Pre-Lab: Collect the Sample**

- Use a container to collect about 2 liters of non-clear water from a river, lake or pond. Put a label on the container and mark the label with the location of the water source.

Alternate Procedure: Add a small amount of dirt to 2 liters of water and shake vigorously to thoroughly mix the dirt and water.

[] **A. Set Up the Equipment**

1. In the lab, measure out 5 g of aluminum sulfate (alum), 2.5 g of iron chloride, and 2.5 g of calcium oxide (lime) onto individual weighing papers.
2. Label the three square bottles. Label one bottle "CONTROL", a second bottle "ALUM", and a third bottle "IRON CHLORIDE + LIME".
3. Use a base and support rod, a lab stand rod, a multi-clamp (right-angle clamp), and two buret clamps to make a stand for the penlight and Light Sensor.
4. Adjust the position of the pen light and the Light Sensor so the square bottle just fits between them. Line up the penlight and the sensor so the light goes in a straight line through the bottle to the sensor. When the Light Sensor, bottle, and penlight are lined up, put strips of tape on the table to trace the position of the square bottle.

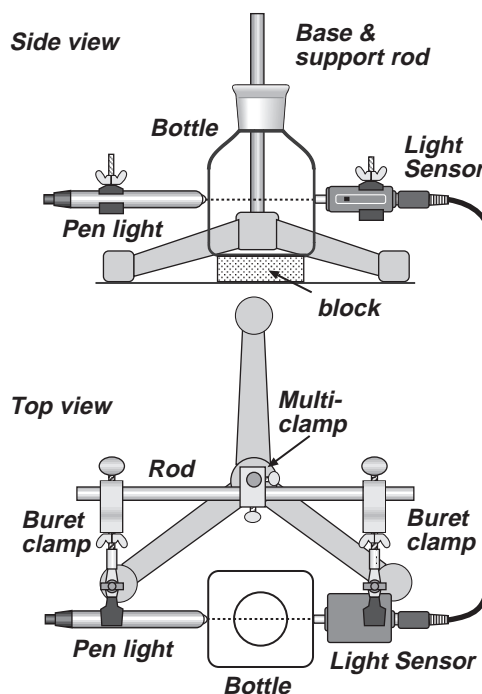

- Use a cardboard box to make a “light shield” that can fit over the penlight, square bottle, and sensor.

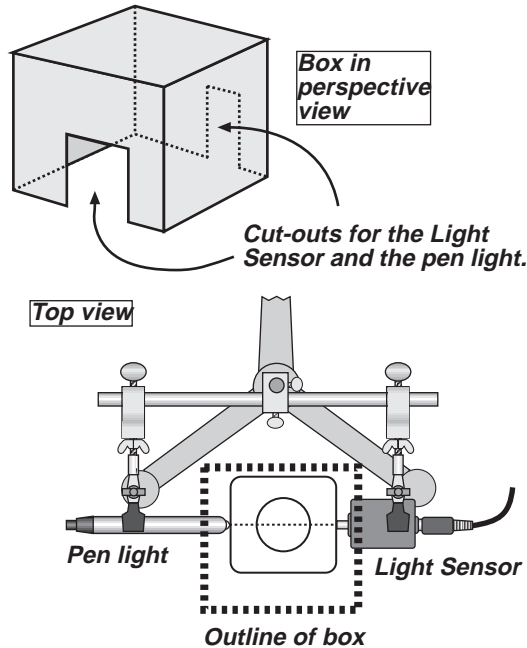

[] B. Set Up the Experiment

Computer Setup

- Connect the Light Sensor DIN plug into Analog Channel A on the *ScienceWorkshop* interface.
- Open the file titled as shown:

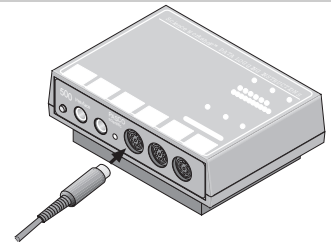

DataStudio	ScienceWorkshop (Mac)	ScienceWorkshop (Win)
S05 Turbidity.ds	S05 Turbidity	S05_TURB.SWS

- The *DataStudio* file has a Workbook display. Read the instructions in the Workbook. The *ScienceWorkshop* file has a Digits display and a Table display. Data recording is preset to stop at 30 seconds.

Sensor Calibration

- Calibrate the Light Sensor using the pen light. Put clear water in the square bottle. Let the light transmitted through the clear water be “100% intensity”.

[✓] Remember, for more detailed information see Appendix A.

[] C. Do the Experiment

1. Set up the water samples:
 - a) Fill each of the three square bottles with 500 mL of muddy, turbid water.
 - b) Add 5 g of *aluminum sulfate* to the bottle labeled ALUM.
 - c) Add 2.5 g of *iron chloride* and 2.5 g of *calcium oxide* to the bottle labeled IRON CHLORIDE + LIME.
2. Shake the bottle labeled CONTROL. Turn on the pen light. Put the bottle exactly between the Light Sensor and pen light. Add the cardboard “light shield” over the sensor and light.

Data Recording Part 1: Beginning

3. When you are ready, record the amount of transmitted light for the water sample in the bottle.
4. Repeat the process for the bottle labeled ALUM, and then for the bottle labeled IRON CHLORIDE + LIME.

Data Recording Part 2: After 30 Minutes

5. Allow the three bottles to set *undisturbed* for 30 minutes.
6. Repeat the measurement of transmitted light for each bottle.
 - Do you need to make the measurement in the same order: CONTROL, then ALUM, then IRON CHLORIDE + LIME?

Challenge your students to analyze the problem.

NOTE: Move the bottles very carefully. Don't shake them or swirl the water.

Data Recording Part 3: After Overnight Rest

7. Allow the three bottles to set *undisturbed* overnight.
8. Repeat the measurement of transmitted light for each bottle.
9. Dispose of the water samples as instructed.

[] D. Analyze the Data

1. Use the Table display to examine each run of data.
 - Hint: Drag data runs to the Table display in *DataStudio* to add data runs to the Table. Use the ‘Add Column’ menu in *ScienceWorkshop* to add data runs to the Table.
2. Determine the average intensity of light that was transmitted through each sample of water at each of the three times. Record the average intensity of light for each sample.
3. Record the light intensity (% max) for each sample of water for each of the three times.

Record your results in the Lab Report section.

Lab Report — Activity S05: Reducing Turbidity in Water

Name _____

Class _____

Date _____

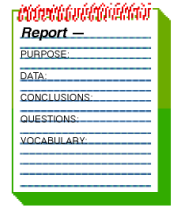

[] What Do You Think?

How does the rate of reducing turbidity in water by sedimentation (allowing suspended matter to settle) compare to the rate of reducing turbidity by flocculation (using chemicals to remove suspended matter)?

Answers will vary. Students may predict that the flocculation method is faster than the sedimentation method.

[] Analyze the Data

1. Use the Table display to determine the *mean* of the light intensity (% max) for each sample of water for each of the three times.
2. Record the light intensity (% max) for each sample of water for each of the three times.

Data Table (Light Sensor)

Trial #	Sample	Time	Clarity (% max light intensity)
1	CONTROL	beginning	20.1
2	ALUM	beginning	20.4
3	IRON CHLORIDE + LIME	beginning	1.38*
4	CONTROL	after 30 min.	30.6
5	ALUM	after 30 min.	75.8
6	IRON CHLORIDE + LIME	after 30 min.	45.4
7	CONTROL	after overnight	69.6
8	ALUM	after overnight	100
9	IRON CHLORIDE + LIME	after overnight	99.5

*The iron chloride/lime combination clouded the water at the very beginning. The iron chloride/lime combination produced the most sediment on the bottom of the bottle.

[] Conclusion

1. How does your hypothesis (answer to “What Do You Think?”) compare with the results?
Answers will vary. One conclusion is that either of the flocculation methods is faster than the sedimentation method.

[] Questions

1. How does sedimentation (the CONTROL) compare to flocculation for the rate of clarifying water?

Answers will vary. In this case, flocculation clarifies the water faster than sedimentation. In fact, the aluminum sulfate completely clarified the water overnight.

2. Which chemical (ALUM or the IRON CHLORIDE + LIME) clarified the water more rapidly?

Of the chemicals used, the alum (aluminum sulfate) clarified the water more rapidly.

Complete the following:

VOCABULARY

floc: Floc is a jelly-like substance formed when certain chemicals are combined in water.

flocculation: Flocculation is a method of reducing turbidity in water that uses chemicals to capture smaller particles of suspended matter.

gelatinous: Gelatinous materials are glue-like or jelly-like.

sedimentation: Sedimentation is a method of reducing turbidity in water in which gravity causes larger particles of suspended matter to settle to the bottom of the water.

Teacher's Notes – Activity S05: Reducing Turbidity in Water

Time Estimates	Preparation: 30 min	Activity: 45 min and overnight
----------------	---------------------	--------------------------------

Objectives

Students will be able to...

- use the Light Sensor to measure the relative intensity of light transmitted through a sample of water
- compare the rate at which different methods (sedimentation and flocculation) reduce turbidity in water

Notes

This activity has two parts: a **COLLECT** part and a **LAB** part

Safety

The **LAB** part of this activity involves chemicals. Please review safety procedures.

Iron chloride has a shelf life of about one year, so check the freshness of the chemicals you use.

The premiere challenge in the **COLLECT** part of this activity is SAFETY. Equally challenging is transportation to and from the water source.

If it is not possible to collect a water sample, make muddy water by adding a small amount of dirt to several liters of water.

Setup

A pen light works well as a light source because the bulb is small and it is easy to line up the bulb with the opening of the Light Sensor. If you do not have a penlight, it may be possible to use a small “Mag Lite”-type flashlight. Remove the lens holder and lens to expose the small bulb.

The Light Sensor and penlight must be carefully aligned for an accurate measurement of clarity. The diagrams in the Procedure Outline and Procedure Details for this activity show one way that the sensor and light source can be mounted using clamps, a rod, and a base and support rod.

Use the cardboard box as a light shield to keep the sensor from being saturated by ambient light.

NOTE: The recommended amount of dirty water to use is 500 mL. If your students use a different amount of water, change the amount of alum and the amount of iron chloride and lime proportionally.

Data Recording

There are three measurements recommended in the procedure outline for this activity:

- 1st: measure how much light is transmitted through each sample of water just after the water is shaken,
- 2nd: measure the light after each sample settles for 30 minutes
- 3rd: measure the light after the samples settle overnight.

Remind your students to use the same sequence for each measurement (1st = CONTROL, 2nd = ALUM, 3rd = IRON CHLORIDE + LIME). This helps assure that the amount of time between measurements for each sample is roughly the same.

The chemicals in this activity can be diluted with water and poured into a drain.

Extension

Filtration vs Sedimentation vs Flocculation

Pour the muddy water through a paper filter. Measure the total time it takes for the water to move through the filter, and then measure the clarity of the filtered water.

Filtration is more time consuming than sedimentation. Water must flow through a filter and the more material the filter traps, the longer it takes for the water to flow. During sedimentation, all of the water is being cleared at the same time.

Procedure Outline — Activity S06: pH of a Natural Water System

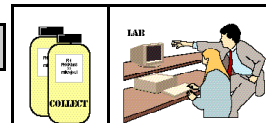

- This activity has two parts: a **COLLECT** part and a **LAB** part.

Equipment Needed	Qty	Per Student	Qty
ScienceWorkshop™ 500 Interface	1	Personal flotation device	1
pH Sensor (CI-6507)	1	Rubber boots (or waders)	1 pr
Beaker, 250 mL	3	Protective gear	1 set
Bottle, clear plastic, ~ 500 mL	5	Consumables	Qty
Marking pen	1	Buffer solution: high pH	100 mL
Wash bottle	1	Buffer solution: low pH	100 mL
Water sampling pole with container	1	Water, distilled	1 L

VOCABULARY	acidic (pH)	acidification	basic (pH)	neutral (pH)
------------	-------------	----------------------	-------------------	---------------------

What Do You Think?

What is the pH at different sections of a natural water system and is there a variation in the pH?



Take time to answer the 'What Do You Think?' question(s) in the Lab Report section.

Background

The pH of a water system depends on various natural conditions and the interaction of humans in the environment. It is important to understand the pH because the aquatic life can only be sustained within a narrow pH range.

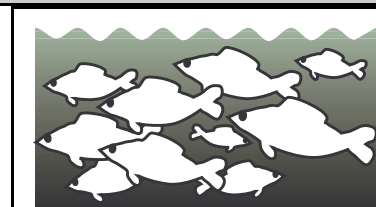

Most aquatic life depends on water that has a pH range between 5 and 9. Water with pH outside that range is unable to sustain life.

Rainwater has a natural tendency to be slightly acidic. Rainfall accumulates in natural water systems causing a slight **acidification**. Rainfall that percolates through dense forest litter and bogs also has a tendency to be more **acidic** because of the interaction of the rainwater with the organic material. In other situations where chalk and limestone are abundant, the water has a tendency to be more **basic**. This is a result of the water mixing with the calcium carbonate found in these regions to make calcium hydroxide which is a base.

Throughout nature, acids and bases are abundant and they are continuously neutralizing each other allowing our natural water systems to remain in the 5-9 pH range.

You will collect some water samples from different parts of a natural water system. In the lab you will use a pH Sensor to measure the pH of each water sample.

SAFETY REMINDERS (COLLECT)

- Wear a personal flotation device (life jacket) when collecting water samples for this activity.
- Wear clothing that is appropriate for the outdoor part of this activity.

SAFETY REMINDERS (LAB)

- Wear protective gear while handling chemicals.
- Follow directions for using the equipment.
- Dispose of all chemicals and solutions properly.



Procedure Outline

In the **COLLECT** part of this activity, collect water samples from different parts of a water system. In the **LAB** part of this activity, use the pH Sensor to measure the pH of collected water samples. Calibrate the pH Sensor before you use it to measure pH.



[✓] Remember, for more detailed information see **Appendix A**.

COLLECT

[] **A. Set Up the Collecting Equipment**

1. Before going out, clean the sample bottles and rinse them with distilled water. Label the first sample bottle SITE #1. Label the other sample bottles SITE #2, SITE #3, SITE #4, and SITE #5.

[] **B. Collect the Samples**

2. Go to a collection site. Record the following for the site in the Report:

• date	• time	• location	• weather conditions
--------	--------	------------	----------------------

3. Use the sampling pole to fill the container with water. Fill the container from a point as far from shore as possible.
 - a. extend the sampling pole straight out over the water
 - b. rotate the pole so the mouth of the collecting container points down
 - c. gently lower the container vertically into the water until the container is fully submerged
 - d. slowly rotate the sampling pole 90 degrees until the mouth of the container is horizontal
 - e. continue to rotate the container until the mouth points up and gently lift the container out of the water
 - f. pour the water from the container into the first sample bottle

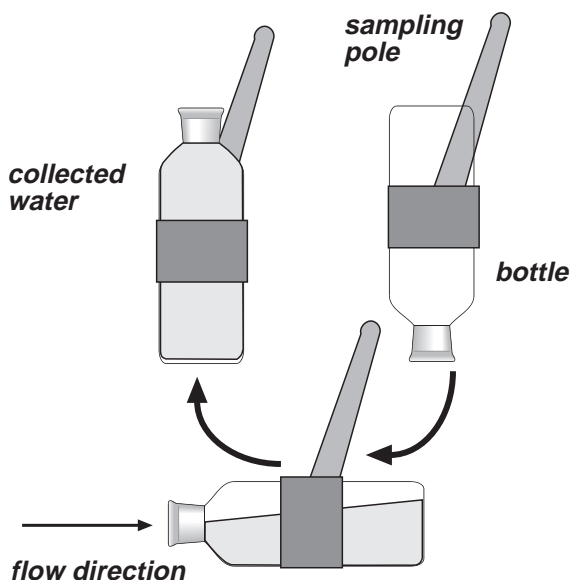

4. Repeat the previous steps for collecting water samples at four more sites.

LAB

[] C. Set Up the Lab Equipment

1. Connect the pH Sensor DIN plug into Analog Channel A on the *ScienceWorkshop* Interface. Connect the BNC plug to the BNC connector.
2. Set up the equipment to calibrate the pH Sensor. To calibrate the pH Sensor you will need the following: wash bottle, distilled water, three beakers, buffer solutions of high pH (e.g. pH 10) and low pH (e.g. pH 4), pH Sensor.
3. Put 100 mL of the high pH buffer solution in one beaker. Put 100 mL of the low pH buffer solution into a second beaker. Put 100 mL of distilled water into the third beaker. Put distilled water into the wash bottle.

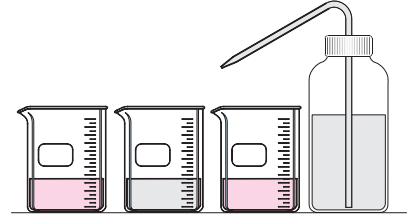

[] D. Set Up The Experiment

1. Connect the sensor to the interface. Start *DataStudio* or *ScienceWorkshop* and open the file as follows:

DataStudio	ScienceWorkshop (Mac)	ScienceWorkshop (Win)
S06 pH of a Stream.DS	S06 pH of Water	S06_PH.SWS

- The file opens with a Digits display and a Table display. The sampling options are set to measure the pH once per second. Data recording is set to stop automatically after 30 seconds.
2. Use the beakers, buffer solutions, and wash bottle to calibrate the pH Sensor.

NOTE: See APPENDIX A for details on how to calibrate the pH Sensor.

[] E. Do the Experiment

1. Put the pH Electrode into the water in one of the sample bottles. Measure the pH of the water. Remove the pH Electrode and rinse it with distilled water.
2. Repeat the previous steps for the remaining water samples.

[] F. Analyze the Data

1. Examine each run of data in the Table display to determine the average pH value of each sample of water. Record the average pH value of each sample.
2. Record your conclusion and answer the questions in the Report.

Record your results in the Lab Report section.

Lab Report — Activity S06: pH of a Natural Water System

Name _____

Class _____

Date _____

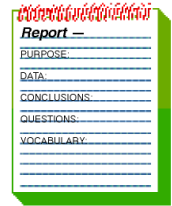

[] What Do You Think?

What is the pH at different sections of a natural water system and is there a variation in the pH?
Answers will vary. Students may predict that the pH of a stream does not vary significantly from one part of the stream to another.

[] Analyze the Data

1. Use the Table display to determine the *mean* of the pH for each sample of water.
2. Record the pH value for each sample of water.

Data Table (pH of a Stream)

Date	Time	Location	Weather Conditions	pH
		<i>fast moving water #1</i>		7.2
		<i>fast moving water #2</i>		7.2
		<i>slow moving water #3</i>		7.1
		<i>slow moving water #4</i>		7.1
		<i>slow moving water #5</i>		7.1

[] Conclusion

1. How does your hypothesis (answer to “What Do You Think?”) compare with the results?
Answers will vary. One conclusion is that the pH of the stream does not vary significantly from one part of the stream to another.

[] Questions

1. Based on the pH data you recorded, could this stream support aquatic life? Why or why not?

Answers will vary. If the stream is polluted, it is possible that the pH level would be lower than 5 or higher than 9, and that the stream could not support aquatic life.

2. What factors do you think may influence the pH of the water in the stream?

Answers will vary. One factor that influences pH of the water in the stream is the chemicals in runoff that enters the stream.

Complete the following:

VOCABULARY

acidic (pH): Acidic substances have a pH value lower than 7 and are sour tasting.

acidification: Acidification of a natural body of water occurs when substances of lower than natural pH enter the water.

basic (pH): Basic substances have a pH value higher than 7 are are bitter tasting.

neutral (pH): Neutral substances have a pH value of 7.

Teacher's Notes – Activity S06: pH of a Natural Water System

Time Estimates	Preparation: 30 min	Activity: 30 min plus travel time
-----------------------	----------------------------	--

Objectives

Students will be able to...

- calibrate a pH Sensor
- use the pH Sensor to measure the pH value of water samples
- predict whether aquatic life can live at the pH level of the stream from which the water samples were taken
- suggest factors that influence the pH of the stream

Notes

This activity has two parts: a **COLLECT** part near water and a **LAB** part. Please review safety procedures.

Safety

The premiere challenge in the **COLLECT** part of this activity is SAFETY. Equally challenging is transportation to and from the water source.

The **LAB** part involves chemicals (buffer solutions).

Setup

Clear plastic water bottles can be used for holding the water samples.

Once the measurements are made, the solutions can be flushed down the drain with large amounts of water. For information on the handling and disposal of chemical solutions, check in the Flinn Scientific catalog. Flinn can be reached at 1-800-452-1261.

Vernier Software sells pH Buffer capsules that can be used to make buffer solutions. Each set contains two capsules for pH buffers 4, 6, and 10 and four capsules for pH buffer 7. These capsules, when added to 100 mL of distilled water, provide reliable buffers for calibrating the pH Sensor. Order code PHB for about \$10. Call 503-297-5317.

Flinn Scientific also sells various buffer solutions.

You can prepare pH buffer solutions as follows:

pH 4 Add 2.0 mL of 0.1 M HCl to 1 L of 0.1 M potassium hydrogen phthalate.

pH 7 Add 582 mL of 0.1 M NaOH to 1 L of 0.1 M potassium dihydrogen phosphate.

pH 10 Add 214 mL of 0.1 M NaOH to 1 L of 0.05 M sodium bicarbonate.

Extension

Make measurements of the pH of water collected from the stream after a rain storm.

If the stream is near agricultural land, make measurements of the pH of water collected from the stream at different times during the growing season.

Procedure Outline — Activity S07: Acid Rain

Adapted from Chemistry with Computers, by Dan D. Holmquist and Donald L. Volz, distributed by Vernier Software, 8565 S.W. Beaverton Hillsdale Hwy., Portland, OR 97225, (503) 297-5317.

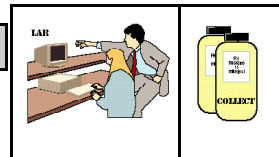

Equipment	Qty	Consumables	Qty
pH Sensor (CI-6507)	1	Buffer solution: high pH	100 mL
Base & Support Rod (ME-9355)	1	Buffer solution: low pH	100 mL
Beaker, 250 mL	3	Sodium hydrogen carbonate, solid	5 g
Beaker, 100 mL	4	Sodium hydrogen sulfite, solid	5 g
Beral-type pipette, 15 cm stem	3	Sodium nitrite, solid	5 g
Beral-type pipette, 2 cm stem	3	Water, distilled	1 L
Beral-type pipette with 1.0 molar HCl	1	Water, tap	12 mL
Clamp, Buret (SE-9446)	1		
Test tube, 20 x 150 mm	1	Per Student	Qty
Wash bottle	1	Protective gear	1 set

VOCABULARY	carbonic acid	nitric acid	sulfurous acid
-------------------	---------------	-------------	----------------

What Do You Think?

What is **acid rain** and what causes it? How much **change in pH in water** is caused by different gases such as carbon dioxide and nitrogen dioxide? What is the pH of rainwater locally?



Take time to answer the 'What Do You Think?' question(s) in the Lab Report section.

Background

Water vapor in the air can combine with other gases found in the air. You may be surprised to learn that rain water is slightly acidic. One reason is that water vapor can combine with carbon dioxide gas to form carbonic acid. The natural pH value of rain water is usually between 6.0 and 6.9. Rainfall accumulates in rivers and streams causing a slight acidification.

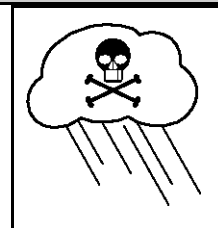

Other gases found in the air can also combine with water vapor to form "acid rain". For example, gases in automobile exhaust and other gases given off by combustion of fossil fuels can combine with water vapor to form sulfurous acid, nitrous acid, and nitric acid.

Carbonic acid is formed when carbon dioxide gas (CO₂) dissolves in rain droplets of unpolluted air:

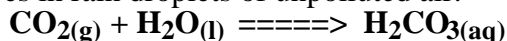

Nitrous acid and nitric acid result from a common air pollutant, nitrogen dioxide (NO₂). Most nitrogen dioxide in our atmosphere is produced from automobile exhaust. Nitrogen dioxide gas dissolves in rain drops and forms nitrous and nitric acid:

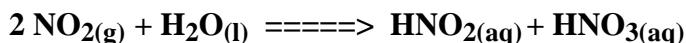

Sulfurous acid is produced from another air pollutant, sulfur dioxide (SO₂). Most sulfur dioxide gas in the atmosphere results from burning coal containing sulfur impurities. Sulfur dioxide dissolves in rain drops and forms sulfurous acid:

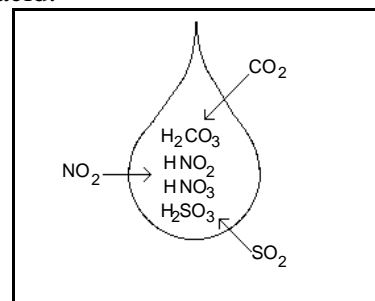
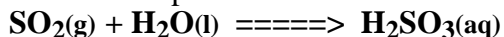

If large amounts of these gases are in the air, the pH of rain water can drop drastically. Rainfall of low pH values directly affect the aquatic life in the rivers and streams where this water accumulates. Acid rain can also cause damage to plant life.

This activity has two parts: a **LAB** part and an *optional* **COLLECT** part. In the lab you will use a pH Sensor to measure the change in the pH in some water as the water absorbs different kinds of gases such as carbon dioxide, nitrogen dioxide, and sulfur dioxide. In the optional part of this activity, you will collect rainwater and measure its pH.

SAFETY REMINDERS (LAB)

- Wear protective gear while handling chemicals.
- Follow directions for using the equipment.
- Dispose of all chemicals and solutions properly.



SAFETY REMINDERS (COLLECT)

- Wear clothing that is appropriate for the outdoor part of this activity.

Procedure Outline

In the lab you will make three *gas generators* (one each for carbon dioxide, nitrogen dioxide, and sulfur dioxide). You will bubble the gas from your gas generators through water, and use the pH Sensor to measure the change in pH of the water as it absorbs the gas. The change in pH created by the carbon dioxide gas will be compared to the change caused by sulfur dioxide and nitrogen dioxide.



[✓] Remember, for more detailed information see **Appendix A**.

[] Pre-Lab: Calibrate the pH Sensor

Use three beakers (100 mL), the buffer solutions, distilled water, and the wash bottle to calibrate the pH Sensor *before* you use it to measure pH.

(NOTE: See *Appendix A* for more information about how to calibrate the pH Sensor.)

[] A. Set Up the Equipment

Overview

Fill three Beral-type pipettes with three different compounds (sodium hydrogen carbonate, sodium hydrogen sulfite, and sodium nitrite). Each of these compounds produces a different gas when hydrochloric acid is added (carbon dioxide from the sodium hydrogen carbonate, sulfur dioxide from the sodium hydrogen sulfite, and nitrogen dioxide from the sodium nitrite).

Add a small amount of hydrochloric acid to each pipette, and transfer the gas it produces to a test tube with water and the pH Sensor in it. Use the pH Sensor to measure the change in pH as the water absorbs the gas.

[] Prepare the gas generators.

1. Label three *short-stem* Beral pipettes with the formula of the solid they will contain: “NaHCO₃” (for sodium hydrogen carbonate), “NaNO₂” (for sodium nitrite) and “NaHSO₃” (for sodium hydrogen sulfite).
2. Label three *long-stem* Beral pipettes with the formula of the gas they will contain: “CO₂” (for carbon dioxide), “NO₂” (for nitrogen dioxide) and “SO₂” (for sodium dioxide). Use the 100 mL beaker to support the pipettes.
3. Your teacher will supply a beaker containing powdered NaHCO₃ (sodium hydrogen carbonate). Squeeze the bulb of the *short-stem* pipette labeled “NaHCO₃” to push the air out of the bulb. Place the open end of the pipette into the powdered NaHCO₃. Release the bulb to draw some of the powdered NaHCO₃ into the pipette. Draw the powder into the pipette until there is just enough powder to fill the curved end of the bulb of the pipette when you hold the pipette with the bulb end down (see the diagram).

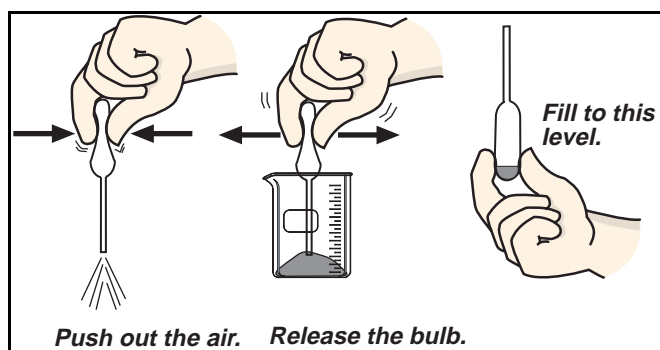

4. Repeat the previous step to fill the “NaNO₂” and “NaHSO₃” *short-stem* Beral pipettes with the corresponding powdered compounds.
5. Get a Beral pipette with 1.0 Molar hydrochloric acid (HCl) from your teacher.

• (Caution: HCl is a strong acid. Hold the pipette gently, with the stem pointing up, so that HCl drops do not escape.)

Insert the narrow stem of the HCl pipette into the larger opening of the pipette with the NaHCO₃ (see the diagram.) Gently squeeze the HCl pipette to add about 20 drops of HCl solution to the powdered NaHCO₃.

When finished, remove the HCl pipette.

Gently swirl the pipette that contains NaHCO₃ and HCl.

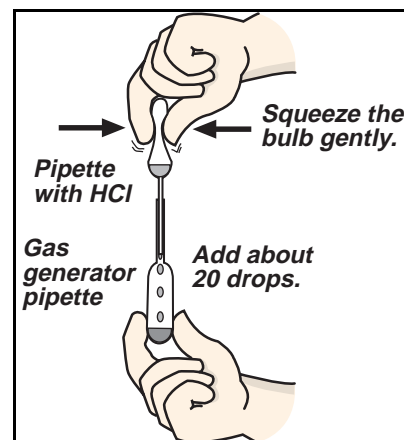

Carbon dioxide gas, CO₂, is generated in this pipette. Place the pipette *bulb down* in the 100 mL beaker to prevent spillage.

6. Repeat this same procedure to add HCl to the pipette with the powdered NaHSO₃ (sodium hydrogen sulfite). Sulfur dioxide, SO₂, is generated in this pipette. Place this pipette *bulb down* in the 100 mL beaker to prevent spillage
7. Repeat this procedure a third time to add HCl to the powdered NaNO₂ (sodium nitrite) pipette. Nitrogen dioxide, NO₂, is generated in this pipette. Return the HCl pipette to your teacher. Leave the three gas-generating pipettes in the 100 mL beaker until needed.

[] **Set up the pH Sensor**

- Attach a 20 x 150 mm test tube to the base and support rod using a clamp. Add about 4 mL of tap water to the test tube. Rinse the pH Electrode with distilled water and place the electrode into the tap water in the test tube.

[] **Collect the gas**

- Squeeze *all* of the air from the bulb of the *long-stem* pipette labeled "CO₂". Keep the bulb completely collapsed and insert the long stem of the pipette down into the gas-generating "NaHCO₃" pipette. The tip of the long-stem pipette should not touch the liquid in the "NaHCO₃" pipette (see the diagram). Release the pressure on the bulb so that it draws gas up into it. Store the long-stem pipette and the "NaHCO₃" pipette *bulb down* in the 100 mL beaker.
- Repeat the procedure using the "NaNO₂" and "NO₂" pipettes and the "NaHSO₃" and "SO₂" pipettes.

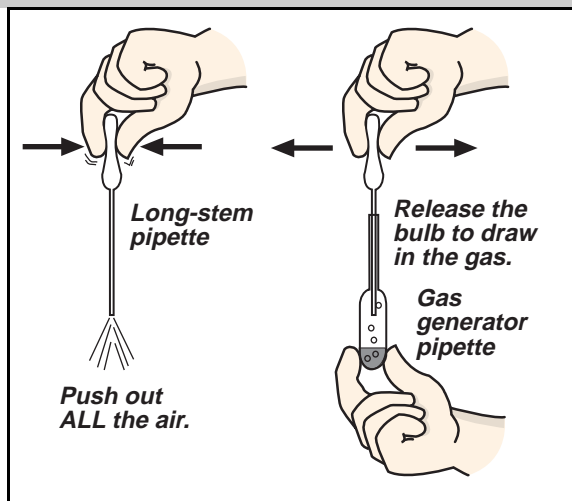

[] **B. Set Up the Experiment**

- Connect the sensor to the interface. Start *DataStudio* or *ScienceWorkshop* and open the file as follows:

DataStudio	ScienceWorkshop (Mac)	ScienceWorkshop (Win)
S07 Acid Rain.DS	S07 Acid Rain	S07_PH.SWS

- The file opens with a Digits display, a Graph display, and a Table display. Data recording is set to stop automatically at 100 seconds.
- Calibrate the sensor. (Remember: See Appendix A for more information.)

[] **C. Do the Experiment**

- Insert the long-stem pipette labeled "CO₂" into the test tube, alongside the pH sensor, so that its tip extends into the water at the bottom of the test tube.
- Begin recording data. After 15 seconds, gently squeeze the bulb of the pipette so that bubbles of CO₂ *slowly* bubble up through the solution. Use both hands to squeeze *all* of the gas from the bulb. Data recording automatically stops at 100 seconds.
- Rinse the pH Electrode thoroughly with distilled water and return it to the sensor storage solution.
- Discard the contents of the test tube as directed by your teacher. Rinse the test tube *thoroughly* with tap water.
- Add 4 mL of tap water to the test tube.
- Repeat the data recording process using NO₂ gas.
- Repeat the data recording process using SO₂ gas.
- When you are finished, rinse the pH Electrode with distilled water and return it to the sensor storage bottle. Dispose of the six pipettes as directed.

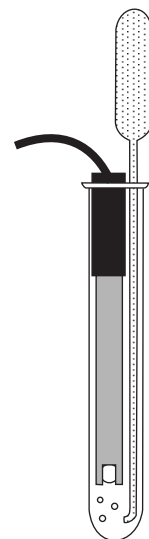

[] **D. Analyze the Data**

1. Examine each run of data in the Table display to determine the minimum pH value and maximum pH value for the water for each gas. Record the values.
2. For each of the three gases, calculate the change in pH and record it.
3. Record your conclusion and answer the questions in the Report.

Record your results in the Lab Report section.

Collect (Optional)

What is the pH of *your* local rainwater?

1. Rinse all glassware with distilled water.
2. Collect water in a rain gauge and pour the water from the rain gauge into a glass beaker.
3. Use the pH Sensor to measure the pH of the rainwater.
4. Examine the data and record the *mean* pH value.
5. Answer the questions in the Report.

Lab Report — Activity S07: Acid Rain

Name _____

Class _____

Date _____

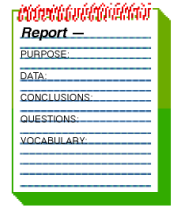

[] What Do You Think?

What is **acid rain** and what causes it? How much **change in pH in water** is caused by different gases such as carbon dioxide and nitrogen dioxide? What is the pH of rain water locally?

Answers will vary. Acid rain occurs when gases such as carbon dioxide and nitrogen dioxide dissolve in water droplets in the atmosphere and fall to the earth as precipitation. Students may predict that nitrogen dioxide will cause more change in the pH of water than carbon dioxide gas.

[] Analyze the Data

1. Use the Table display to determine the minimum pH value and maximum pH value for the water for each gas.
2. For each of the three gases, calculate the change in pH by subtracting the minimum pH from the maximum pH.

DATA TABLE (Acid Rain)

Gas	Minimum pH	Maximum pH	Change in pH
carbon dioxide, CO ₂	6.5	7.2	0.7
nitrogen dioxide, NO ₂	3.4	7.0	3.6
sulfur dioxide, SO ₂	3.9	6.6	2.7

3. Use the Graph display to see how much the pH changes for each gas.
4. For each of the three gases, sketch the change in pH.

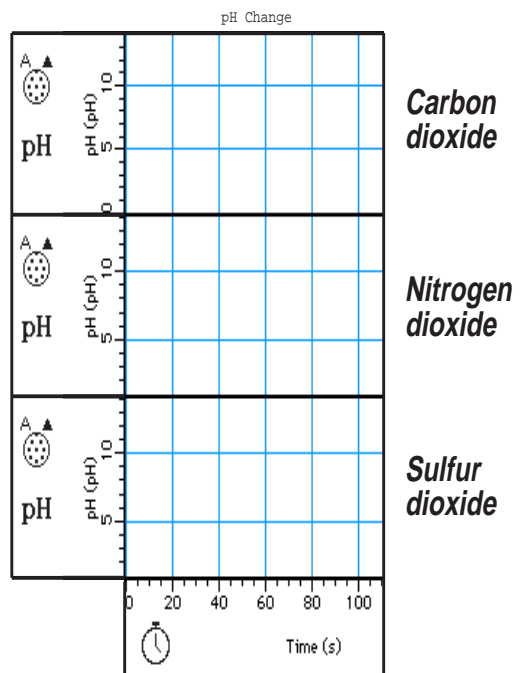

[] Conclusion

1. How does your hypothesis (answer to the 'What Do You Think? Question) compare with the results?

Answers will vary. One conclusion is that carbon dioxide gas causes much less change in the pH of rain water than does nitrogen dioxide or sulfur dioxide

[] Questions

1. In this activity, which gas caused the smallest drop in pH?
Carbon dioxide caused the lowest drop in pH.
2. Which gas caused the largest drop in pH?
Nitrogen dioxide caused the greatest drop in pH.
3. High temperatures in the automobile engines cause nitrogen and oxygen gases from the air to react and form nitrogen oxides. What two acids in acid rain result from the nitrogen oxides found in automobile exhaust?

Nitrous acid and nitric acid result from the nitrogen oxides found in automobile exhaust.

Complete the following:

VOCABULARY

carbonic acid: Carbonic acid is formed when carbon dioxide gas dissolves in water.

nitric acid: Nitric acid forms when nitrogen dioxide gas dissolves in water.

sulfurous acid: Sulfurous acid forms when sulfur dioxide gas dissolves in water.

If you completed the optional **COLLECT** part of this activity, answer the following.

1. What was the mean (average) pH of the rain water you collected?
Answers will vary. _____
2. How does the pH of the rain water compare to the pH of the water collected from the stream?
In general, the pH of the rain water will be slightly lower than the pH of the water collected from the stream.

3. What factors do you think have influenced the pH of the rain water?
Answers will vary. _____

Teacher's Notes – Activity S07: Acid Rain

Time Estimates	Preparation: 30 min	Activity: 30 min
-----------------------	----------------------------	-------------------------

Objectives

Students will be able to...

- calibrate a pH Sensor
- use the pH Sensor to measure the pH value of water as different gases are dissolved in the water
- determine which gas causes the greatest change in the pH value of the water

Notes

This is a **LAB** activity that involves chemicals. Please review safety procedures.

Setup

Vernier Software sells pH Buffer capsules that can be used to make buffer solutions. Each set contains two capsules for pH buffers 4, 6, and 10 and four capsules for pH buffer 7. These capsules, when added to 100 mL of distilled water, provide reliable buffers for calibrating the pH Sensor. Order code PHB for about \$10. Call 503-297-5317.

Flinn Scientific also sells various buffer solutions.

You can prepare pH buffer solutions as follows:

pH 4 Add 2.0 mL of 0.1 M HCl to 1 L of 0.1 M potassium hydrogen phthalate.

pH 7 Add 582 mL of 0.1 M NaOH to 1 L of 0.1 M potassium dihydrogen phosphate.

pH 10 Add 214 mL of 0.1 M NaOH to 1 L of 0.05 M sodium bicarbonate.

1. Plan to spend some time teaching your students how to make the gas-generating pipettes and to use the Beral-type pipette to transfer gas to the test tube.
2. Thin stem Beral pipettes are available from Flinn Scientific (800-452-1261) and Sarget-Welch (800-727-4368). You can empty the pipettes and discard them after using. You may also choose to clean and re-use them.
3. The Beral pipette used for gas-collecting and the Beral pipette used to dispense the hydrochloric acid need to have a very narrow stem. To make the stem narrower, place the pipette bulb in the palm of one hand with your thumb against the stem where it joins the bulb. Firmly grip the middle of the stem with your other hand and pull hard on the stem until it yields to the pressure and stretches out to a uniform narrow diameter.
 - You can easily stretch it to the length you need (15 cm) for the gas-collecting pipettes. Cut the stems to a length of 4 cm for the hydrochloric acid dispensing pipettes.
 - For the gas-generating pipettes, cut the stem of a regular new Beral pipette to a length of 3 cm. Since its stem is wider, the hydrochloric dispensing pipette and the gas-collecting pipette will easily fit into it.
4. Instead of using a beaker to support the pipettes, you can also use a test tube rack.

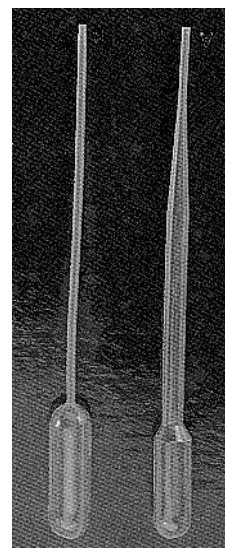

- Whether you choose to discard or recycle the pipettes, we recommend that you not let your students empty the pipettes. Empty the gas-generating pipettes under a fume hood.
- If you reuse the gas-generating pipettes, make sure they are completely dry. The sulfur dioxide and nitrogen dioxide gases are highly soluble in water.
- The 1.0 Molar hydrochloric acid can be prepared by adding 8.6 mL of concentrated acid per 100 mL of solution. Draw the acid solution into a thin stem Beral pipette. Each trial requires about 1 mL of acid, or a total of 3 mL for three gases. Fill the bulb about three-quarters full.
- Put about 1 to 2 cm of solid NaHCO_3 , NaHSO_3 , and NaNO_2 in 100 mL beakers. Students may have a little difficulty drawing up the granular NaNO_2 into their pipettes. The other solids are not difficult.
- Distilled water may be used in place of tap water, but tap water generally contains enough dissolved carbon dioxide, carbonate, and hydrogen carbonate to give it a small amount of buffering.
- The 20 x 150 mm test tube is large enough for the pH electrode and the stem of the Beral pipette. A smaller 18 x 150 mm test tube will not be large enough.

Data Recording

The pH Sensor should be calibrated before it is used to measure pH values.

Extensions

Do research on the problems created by acid rain.

Do research on the problems associated with trying to reduce or eliminate acid rain.

Sample Data

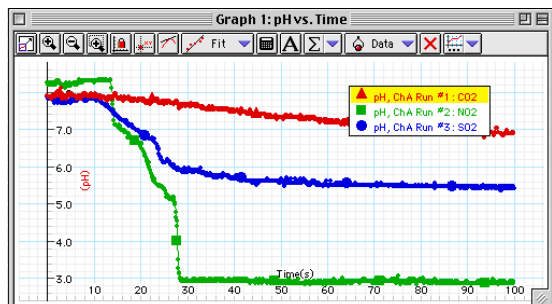

DataStudio: all three runs of data

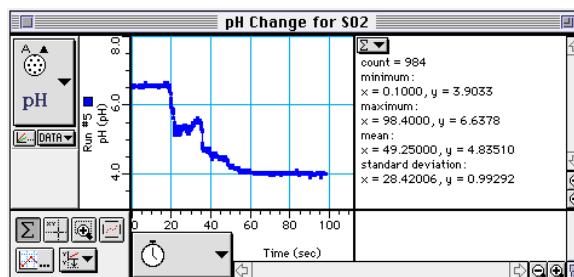

ScienceWorkshop: SO₂

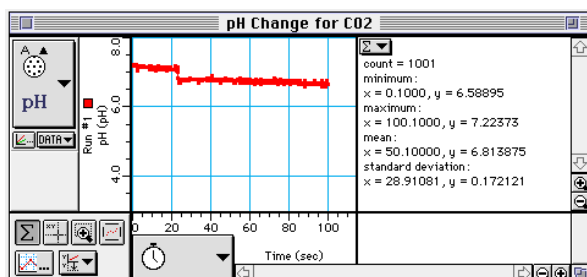

ScienceWorkshop: CO₂

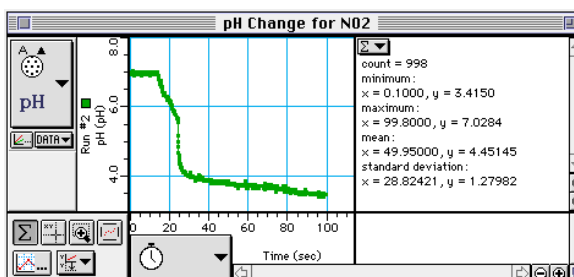

ScienceWorkshop: NO₂

Overview – Appendix A

This appendix for *Part 1: Stewardship - The Water Planet* of Earth Science Labs with Computers gives procedure *details* for each activity. For example, the procedure details include step-by-step instructions for setting up equipment, connecting sensors to the *ScienceWorkshop* interface, or calibrating a sensor.

Use this appendix when you have questions about setting up equipment or recording data for an activity.

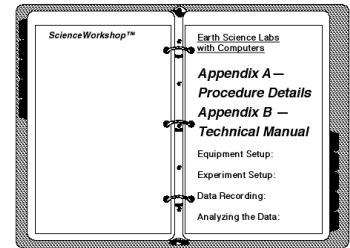

Appendix A Contents

S01	Streams and Rivers Procedure Details	71
S02	Measure Stream Flow Procedure Details.....	73
S03	Temperature of Flowing Water Procedure Details.....	77
S04	Clarity and Turbidity in Water Procedure Details.....	81
S05	Reducing Turbidity in Water Procedure Details.....	85
S06	pH of a Natural Water System Procedure Details	87
S07	Acid Rain: Detection and Causes Procedure Details.....	91

Procedure Details — Activity S01: Streams and Rivers

This part of Appendix A gives information about setting up a stream table to observe how a stream or river cuts a path in the ground to form a channel and deposit material to form a delta and how the course of a stream or river changes over time.



The stream table is a model of a stream or river. The material in the stream table simulates the ground over which a stream or river can flow. Water that is poured into one end of the stream table simulates the stream or river.

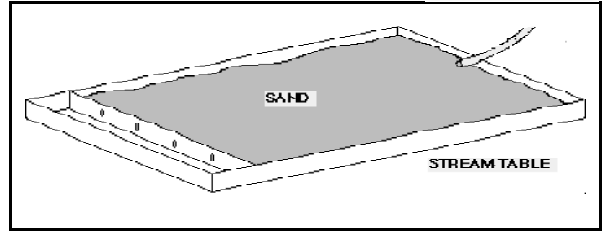

[] A. Set Up the Equipment

1. Dampen the sand. Arrange the sand in the stream table so that the sand is level.

- Use the edge of a ruler or a piece of stiff cardboard to move and level the sand.

2. Set up the stream table so the stream table makes an angle of about 6° relative to horizontal.

- Lift one end of the table. Use the protractor to measure the angle. Place the protractor at the low end of the table to measure the angle.

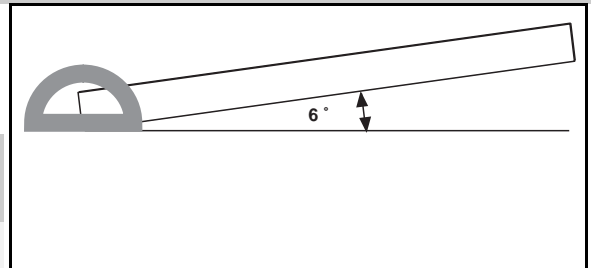

3. Set up the water supply system.

- Put the end of the funnel into one end of the plastic tubing. Push the end of the tubing over the narrow end of the funnel. Place the other end of the tubing near the surface of the sand at the raised end of the stream table. Fill the container with water and prepare to pour the water into the funnel.

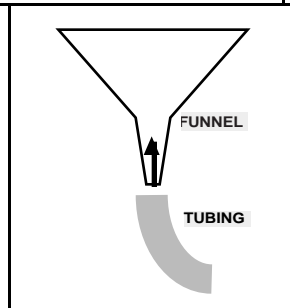

[] B. Set Up the Experiment

4. Determine the percent grade (% grade) of the stream table.

- To determine the % grade, measure the height "h" of the raised end of the stream table is above the horizontal.
- Measure the horizontal distance "d" that the water will move.
- Divide the height of the raised end by the horizontal distance.
- Convert the decimal to a percent as shown:

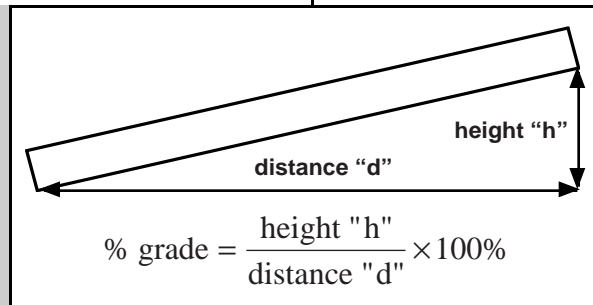

[] C. Do the Experiment

5. Trial 1: *Normal conditions*. Pour water from the container into the funnel so water flows through the tubing onto the upper end of the stream table. Allow the water to flow gently onto the surface of the sand for five minutes. Observe what happens and record your observations.

- Let water flow at an even rate. See the diagram.

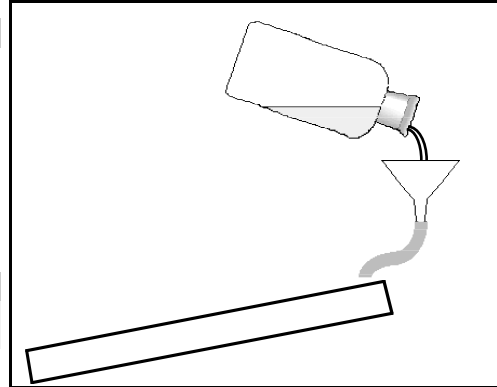

6. Trial 2: *Change the angle* of the stream table. Repack the sand or use a fresh part of the stream table. Determine the percent grade (% grade) of the table. Record the angle and the percent grade as part of Trial 2 in the Report. Let water flow onto the sand for five minutes. Record your observations.

7. Trial 3: *Reduced water flow*. Repack the sand or use a fresh part of the stream table. Keep the angle of the stream table the same. Let water flow slowly onto the sand for five minutes. Record your observations.

- Reduce the flow by squeezing the tubing or by holding your thumb in front of the opening of the tube.

8. Trial 4: *Artificial channel*. Repack the sand. Put the stream table at a low angle. Carve an “S” shaped stream bed in the sand with your finger. Run the water down it for five minutes. Record your observations.

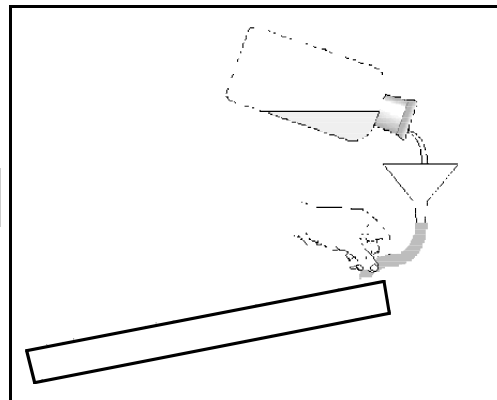

9. Trial 5: *Level area*. Repack the sand so there is a slope leading to a flat, level area near the base. As you run water down the slope, observe what happens when the water reaches the level area. Record your observations.

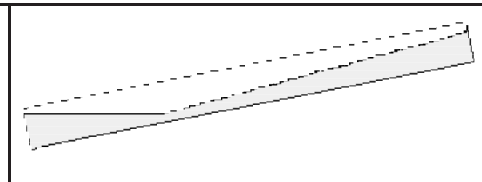

10. Trial 6: *Different material*. Repack your stream table with a mixture of moist sand, clay, and pebbles. Run the water down it for five minutes. Record your observations.

[] D. Analyze the Data

11. Examine the observations you have recorded in the Report to determine the relationship of the shape of a stream or river to natural factors such as the following:

steepness (angle) of slope	rate of water flow
shape of the existing ground material	type of ground material

12. Write your conclusion and answer the questions in the Report.

Optional: Design a Stream Habitat

- Discuss, brainstorm, design, sketch, build, predict, and test. Share your results.

Procedure Details — Activity S02: Measure Flow Rate

This part of Appendix A gives information about how to use the Flow Rate Sensor to measure the flow rate of water in a stream or river.

The Flow Rate Sensor is designed to measure the speed of water flowing through the sensor. The sensor uses a small propeller that rotates as water moves past it.

About the Flow Rate Sensor

The propeller has two blades, each with a small magnet on the tip. When the propeller tips pass by a tiny coil of wire built into the housing, an electrical impulse is created and sent to the interface.

The propeller makes five complete turns for each linear foot of water that flows through it. Ten pulses are created for each linear foot of water. The program records the time between each electrical impulse, and converts the times into a speed (flow rate) measurement.

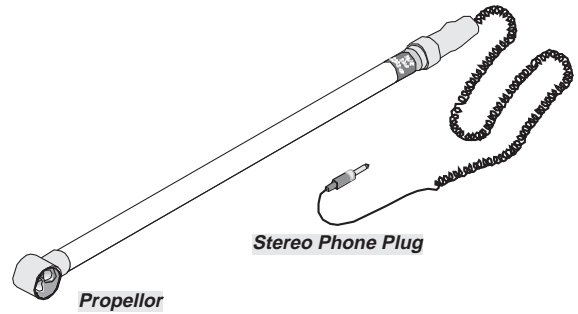

[] A. Set Up the Equipment

1. Extend the Flow Rate Sensor to its full length.
 - Twist the larger knurled ring next to the handle left-to-right (counterclockwise) to loosen the ring.
 - Pull the handle to extend the length of the sensor.
 - Twist the knurled ring right-to-left (clockwise) to tighten the ring again.
2. Use waterproof tape to put reference marks at equal intervals along the shaft of the Flow Rate Sensor.
 - For example, you could put reference marks every 30 cm (0.30 m). Measure from the center of the propeller.

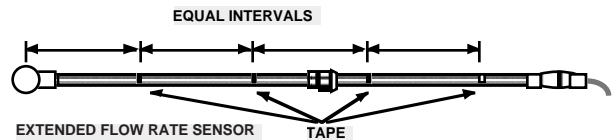

[] B. Set Up the Experiment

1. Start *DataStudio* or *ScienceWorkshop* and open the file as follows:

DataStudio	ScienceWorkshop (Mac)	ScienceWorkshop (Win)
S02 Stream Flow.DS	S02 Flow Rate	S02_FLOW.SWS

- Select 'Open' from the 'File' menu.
- Go to the Experiment Library. Find the document labeled as shown above. Double-click the document filename or select it and click OK or 'Open'.
- The file opens with a Graph display.

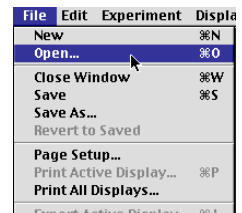

2. Prepare the *ScienceWorkshop* interface for data logging.
 - Make sure that there are four AA alkaline batteries in the interface battery compartment.
 - Make sure that the POWER switch on the back panel of the interface is ON.

3. Set up the software for data logging.
 - In *DataStudio*, click the ‘Experiment’ menu in the menu bar and select ‘Disconnect for

Logging’ or click ‘Logging’ () in the Setup window toolbar. In *ScienceWorkshop*, click the ‘Experiment’ menu and select ‘Disconnect for Logging...’.

- In *DataStudio*, a window opens reminding you that you can print an experiment summary if you want. (If your computer is connected to a printer you can print an experiment summary.) After you click ‘Yes’ or ‘No’, the software is ready for data logging.

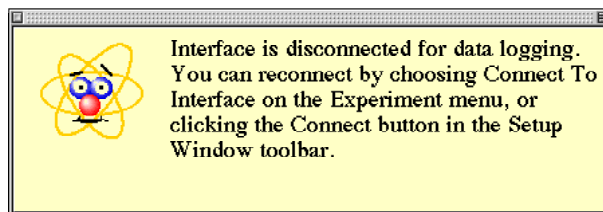
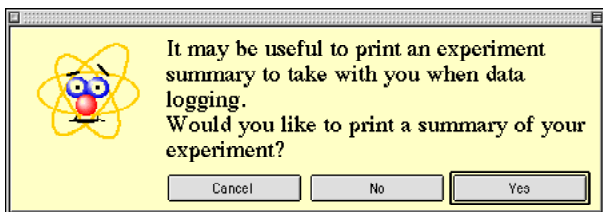

- In *ScienceWorkshop*, the Data Logging Setup window opens. (If your computer is connected to a printer you can print a checklist.) Click ‘Begin Logging’ when you are ready to begin data logging.

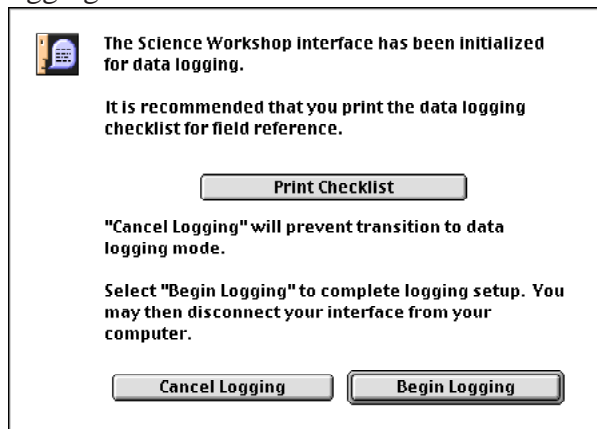

- The interface goes into “sleep” mode. The green light-emitting diode (LED) on the front panel of the interface will go out, and then will blink once every five seconds.

4. Disconnect the interface from the computer. Unplug the power cord and the interface cable from the back of the interface box. (It doesn’t matter which is unplugged first).

5. Carry the interface and Flow Rate Sensor to the experiment site.

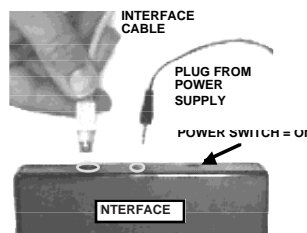

[] **C. Do the Experiment**

- For the first part of your data collecting, record the flow rate of the stream or river at three different depths at one position.
- For the second part of your data collecting, record the flow rate at a constant depth, but at three different positions relative to the shore or bank.
- In the final part of the data collecting, record the flow at a narrow section of the stream or river and then measure the flow at a wider section of the stream or river.

1. Connect the Flow Rate Sensor plug into Digital Channel 1 on the interface box.

- Push the stereo phone plug into Digital Channel 1 until the plug is all the way into the interface.

2. Extend the Flow Rate Sensor and place the end in the water at the first depth. Hold onto the sensor with two hands.

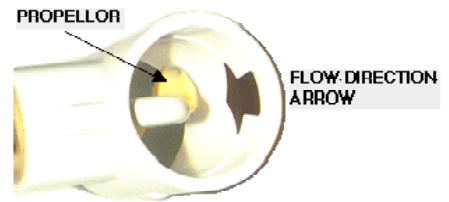

- Note that the sensor has a flow direction arrow on the propeller housing. When you put the end of the sensor into the water, be sure that the arrow points in the direction that the water is flowing.

3. When you are ready, press the LOG button on the front of the interface.

- Remember, the interface waits 10 seconds before it begins to record data. The green LED on the front of the interface will blink once per second for ten seconds while the interface is waking up. Then the green LED blinks rapidly while data are being recorded.

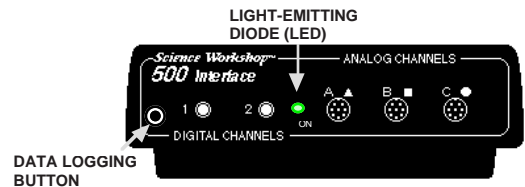





4. Record data at the first location for about one minute. Press the LOG button again to stop recording data.

- The green LED will go out and then it will blink once every five seconds.

5. Repeat the data recording process for the other depths, different locations relative to the shore, and for the narrow and wide sections of the river or stream.

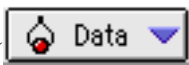
6. After you collect your data, disconnect the Flow Rate Sensor from the interface. Be sure the interface is in the 'sleep' mode.

[] **D. Analyze the Data**

1. Reconnect the interface to the power supply and computer.
 - Plug the interface cable and power supply cable into the back of the interface box. It doesn't matter which one is plugged in first.
2. Download data from the interface to the computer. (See Appendix C.)
 - In *DataStudio*, select 'Connect to Interface...' in the Experiment menu or click 'Connect' () in the Setup window toolbar. In *ScienceWorkshop*, select 'Connect to Interface' in the Experiment menu. The data will be downloaded automatically.
3. Examine each run of data in the Graph display to determine the relationship of the flow rate to depth, location relative to shore, and shape of the stream or river. Use the Graph display's built-in statistics to find the 'Mean' of the flow rate.
 - In *DataStudio*, click 'Data' () in the Graph toolbar to select a run of data. In *ScienceWorkshop*, click 'Data' () on the left side of the Graph display or select a run of data the bottom of the Experiment menu.
 - In *DataStudio*, click 'Statistics' () in the Graph toolbar and select 'Mean'. The value appears in the Graph Legend. In *ScienceWorkshop*, click 'Statistics' () in the lower left corner of the Graph to open the statistics area and select 'Mean' from the 'Statistics Menu' (). The value appears in the statistics area.
4. Record the 'Mean' values and write your conclusions and answer the questions in the Report.

Procedure Details — Activity S03: Temperature of Flowing Water

This part of Appendix A gives information about how to use the Temperature Sensor to measure the temperature of flowing water in a stream or river.



About the Temperature Sensor

The Temperature Sensor is designed to measure the temperature of water and other liquids. The sensor has a small transistor in its tip that produces a voltage that matches the temperature.

The sensor produces 10 millivolts (0.01 volts) for every degree Celsius of temperature. The program converts the voltage into a digital (numeric) value of temperature.

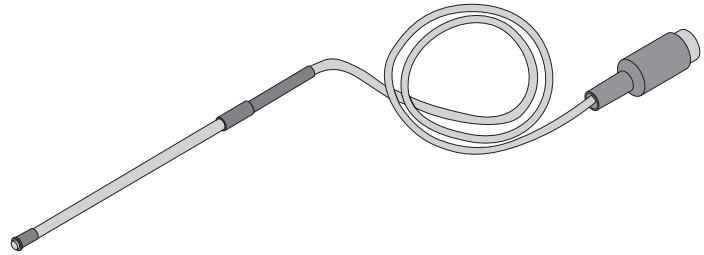

The sensor is covered with protective Teflon except at the very tip. The sensor comes with a separate Teflon cover that can be slipped over the end of the sensor for extra protection from corrosive or caustic chemicals.

[] A. Set Up the Equipment

1. Use rubber bands to fasten the Temperature Sensor to one end of a 2-m pole.
 - Tie the sensor's cord to the pole so the cord doesn't get tangled.
 - Attach the DIN-to-DIN sensor cable to the end of the Temperature Sensor's cable.
 - Use the extender cable that comes with the Light Sensor.
 - Place the sensor against the pole so that the tip extends slightly beyond the end of the pole.
 - Loop the rubber bands several times around the sensor so it is secure.

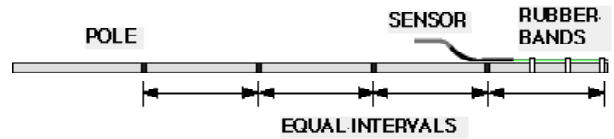

2. Use a marker pen to put reference marks at equal intervals along the pole.
 - For example, you could put reference marks every 30 cm (0.30 m). Measure from the tip of the sensor.



[] B. Set Up the Experiment

1. Connect the sensor to the interface. Then start *DataStudio* or *ScienceWorkshop* and open the file as follows:

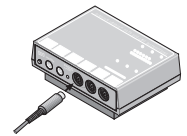

DataStudio	ScienceWorkshop (Mac)	ScienceWorkshop (Win)
S03 Stream Temp.DS	S03 Temperature Flow	S03_TEMP.SWS

- Select 'Open' from the 'File' menu.
- Go to the Experiment Library. Find the document labeled as shown above. Double-click the document filename or select it and click OK or 'Open'.
- The file opens with a Graph display.

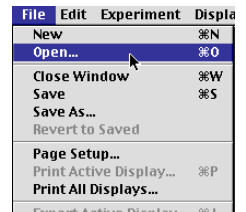

2. Prepare the *ScienceWorkshop* interface for data logging.
 - Make sure that there are four AA alkaline batteries in the interface battery compartment.
 - Make sure that the POWER switch on the back panel of the interface is ON.

3. Set up the software for data logging.
 - In *DataStudio*, click the 'Experiment' menu in the menu bar and select 'Disconnect for

Logging' or click 'Logging' () in the Setup window toolbar. In *ScienceWorkshop*, click the 'Experiment' menu and select 'Disconnect for Logging...".

- In *DataStudio*, a window opens reminding you that you can print an experiment summary if you want. (If your computer is connected to a printer you can print an experiment summary.) After you click 'Yes' or 'No', the software is ready for data logging.

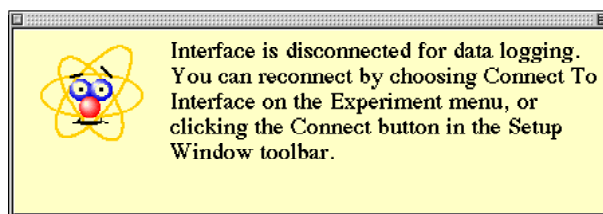
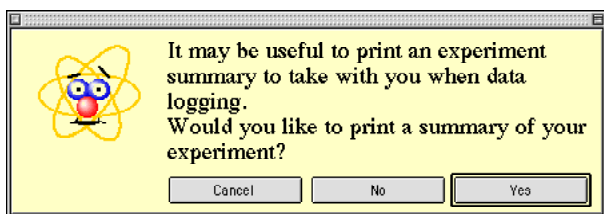

- In *ScienceWorkshop*, the Data Logging Setup window opens. (If your computer is connected to a printer you can print a checklist.) Click 'Begin Logging' when you are ready to begin data logging.

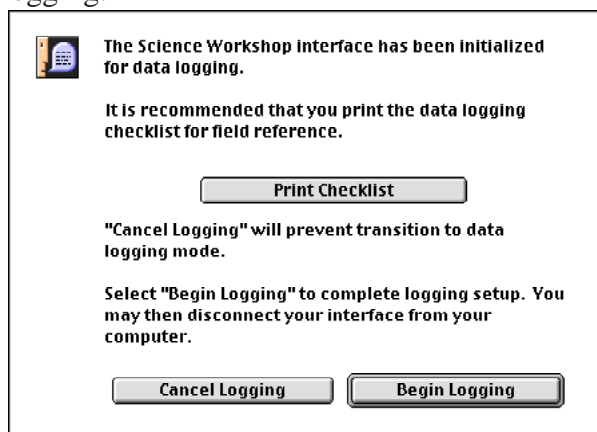

- The interface goes into "sleep" mode. The green light-emitting diode (LED) on the front panel of the interface will go out, and then will blink once every five seconds.

4. Disconnect the interface from the computer. Unplug the power cord and the interface cable from the back of the interface box. (It doesn't matter which is unplugged first).

5. Carry the interface and Temperature Sensor to the experiment site.

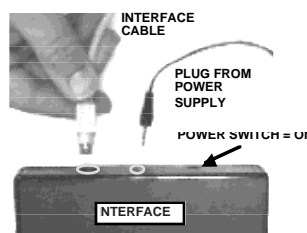





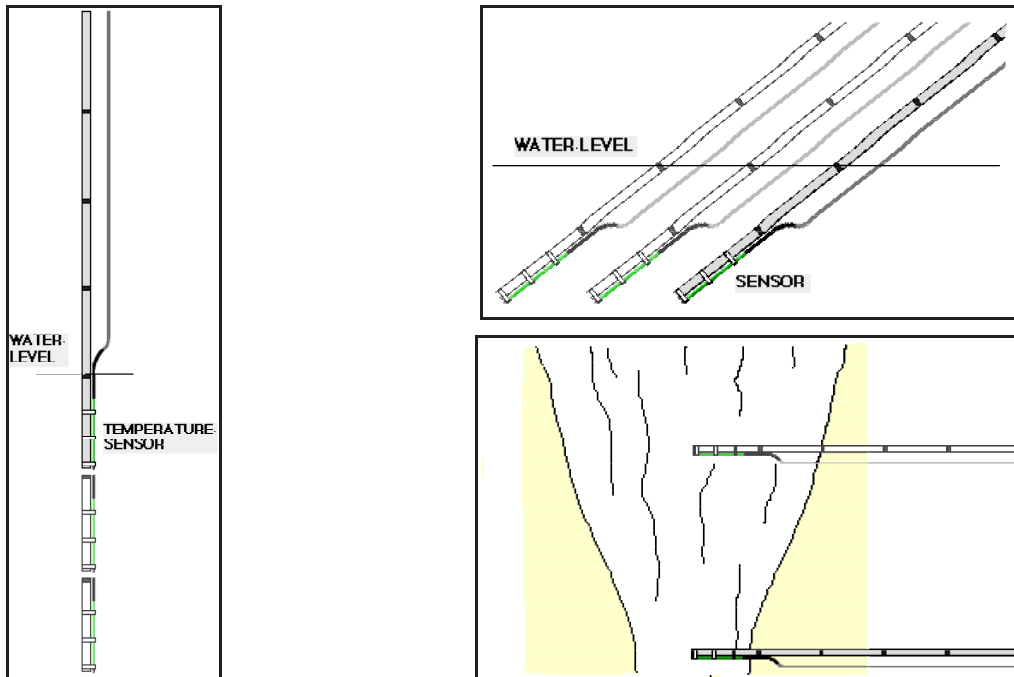

[] C. Do the Experiment

- For the first part of your data collecting, record the temperature of the stream or river at three different depths at one position.
- For the second part of your data collecting, record the temperature at a constant depth, but at three different positions relative to the shore or bank.
- In the final part of the data collecting, record the temperature at a narrow section of the stream or river and then measure the temperature at a wider section of the stream or river.
- When you put the Temperature Sensor into the water, don't go beyond the Temperature Sensor's DIN plug. If the sensor's DIN plug gets wet, water may seep up the DIN-to-DIN cable into the interface.



1. Connect the Temperature Sensor plug into Analog Channel A on the interface box.
- Push the DIN plug into Analog Channel A until the plug is all the way into the interface.
2. Place the end of the sensor in the water at the first depth.
- Hold onto the pole with both hands.
3. When you are ready, press the LOG button on the front of the interface.
- Remember, the interface waits 10 seconds before it begins to record data.
- The green LED on the front of the interface will blink once per second for ten seconds while the interface is waking up. Then the green LED blinks rapidly while data are being recorded.
4. Record data at the first location for about one minute. Press the LOG button again to stop recording data.
- The green LED will go out and then it will blink once every five seconds.
5. Repeat the data recording process for the other depths, different locations relative to the shore, and for the narrow and wide sections of the river or stream.

[] **D. Analyze the Data**

1. Reconnect the interface to the power supply and computer.
 - Plug the interface cable and power supply cable into the back of the interface box. It doesn't matter which one is plugged in first.
2. Download data from the interface to the computer. (See Appendix C.)
 - In *DataStudio*, select 'Connect to Interface...' in the Experiment menu or click 'Connect' () in the Setup window toolbar. In *ScienceWorkshop*, select 'Connect to Interface' in the Experiment menu. The data will be downloaded automatically.
3. Examine each run of data in the Graph display to determine the relationship of the flow rate to depth, location relative to shore, and shape of the stream or river. Use the Graph display's built-in statistics to find the 'Mean' of the flow rate.
 - In *DataStudio*, click 'Data' () in the Graph toolbar to select a run of data. In *ScienceWorkshop*, click 'Data' () on the left side of the Graph display or select a run of data the bottom of the Experiment menu.
 - In *DataStudio*, click 'Statistics' () in the Graph toolbar and select 'Mean'. The value appears in the Graph Legend. In *ScienceWorkshop*, click 'Statistics' () in the lower left corner of the Graph to open the statistics area and select 'Mean' from the 'Statistics Menu' (). The value appears in the statistics area.
4. Record the 'Mean' values and write your conclusions and answer the questions in the Report.

Procedure Details — Activity S04: Clarity and Turbidity in Water

This part of Appendix A gives information about how to use the Light Sensor to measure the clarity of water and the Secchi disk symbol to measure turbidity.



About the Light Sensor

The Light Sensor is designed to measure the relative intensity of light. The sensor has a sensitive photodiode that creates a voltage when light shines on it.

The sensor has an aperture at one end that lets light into the photodiode. The other end of the sensor has a five pin DIN plug. This can connect directly into the interface, or it can connect into an interface cable.

The software converts the voltage from the sensor into a digital (numeric) value of relative intensity. First, the sensor is calibrated to the maximum intensity of a given light source. Then, the light intensity during the activity is measured as a percent of the maximum (& max).

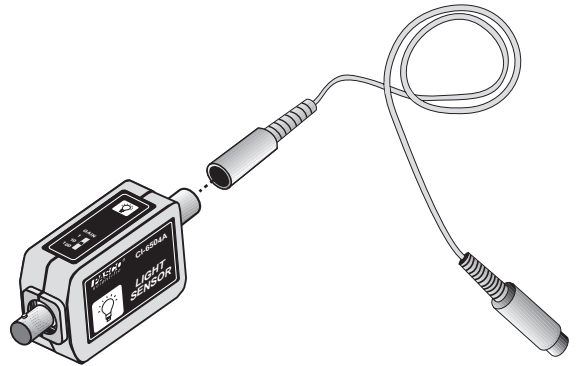

[] Pre-Lab: Collect the Sample

1. Use a container to collect about 2 liters of non-clear water from a river, lake or pond. Put a label on the container and mark the label with the location of the water source.
 - For example, tie a rope or cord to a bucket and lower the bucket into the water.

Alternate Procedure

- Add a small amount of dirt to 2 liters of water and shake vigorously to thoroughly mix the dirt and water.
- A little dirt goes a long way. Don't add too much, or the water will become too muddy.

[] A. Set Up the Equipment

Turbidity

A Secchi disk is a circular disk, 20 cm (0.20 m) in diameter, that is divided into four quarters. The quarters are alternately painted black and white. A cord or chain is attached to the disk so the disk can be lowered vertically into the water. The cord or chain is calibrated in equal intervals so the depth can be measured.

You will use a Secchi disk *symbol* instead of a Secchi disk.

1. Place the Secchi disk symbol on a flat surface. Place a graduated cylinder on the center of the disk.

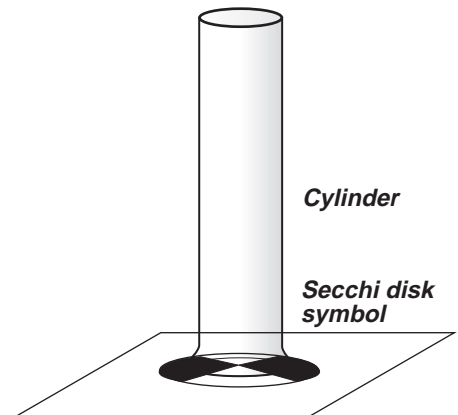

Clarity

- Use a base and support rod, a lab stand rod, a multi-clamp (right-angle clamp), and two buret clamps to make a stand for the penlight and Light Sensor.
- Adjust the position of the penlight and the Light Sensor so the square bottle just fits between them. Line up the penlight and the sensor so the light goes in a straight line through the bottle to the sensor.

- When the Light Sensor, bottle, and penlight are lined up, put strips of tape on the table to trace the position of the square bottle.
- Mark the position of the bottle so you can put it in the same place each time you make a measurement.

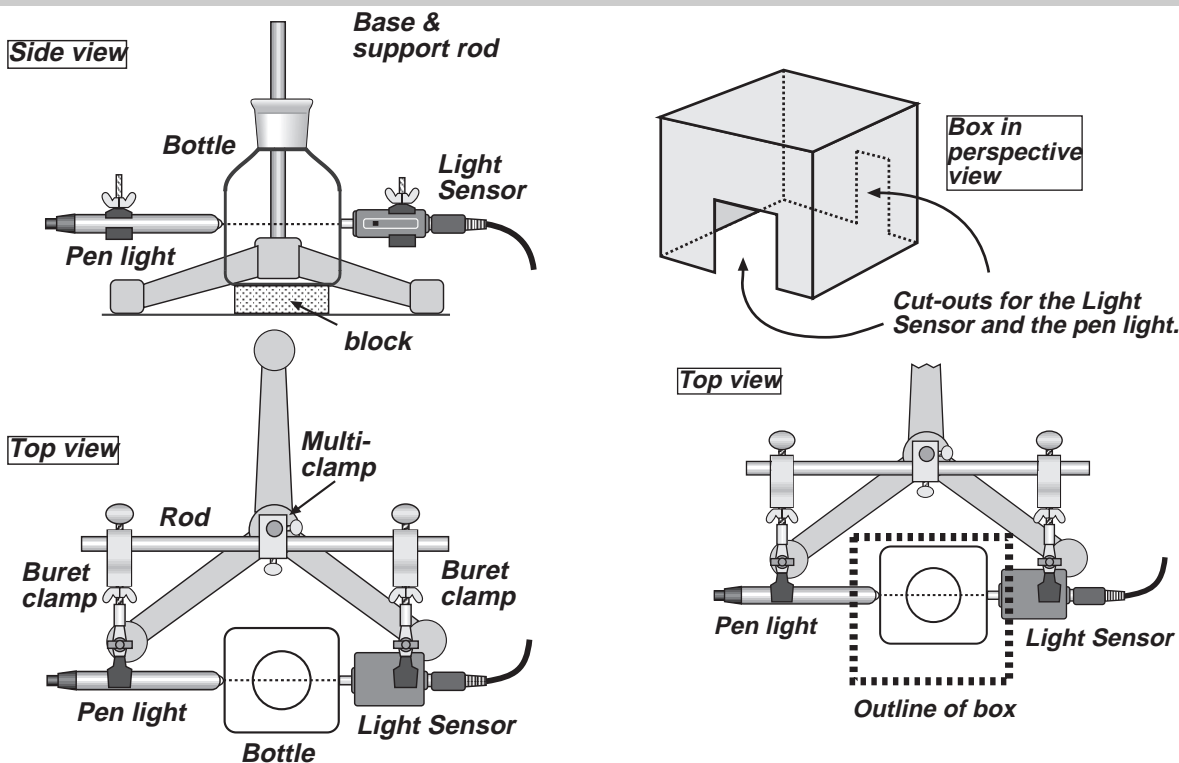

- Use a cardboard box to make a “light shield” that can fit over the penlight, square bottle, and sensor.

[] B. Set Up the Experiment

- Connect the Light Sensor DIN plug into Analog Channel A on the interface.
- Start *DataStudio* or *ScienceWorkshop* and open the file as follows:

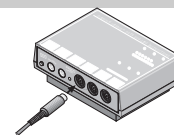

DataStudio	ScienceWorkshop (Mac)	ScienceWorkshop (Win)
S04 Clarity.DS	S04 Clarity	S04_CLAR.SWS

- Select ‘Open’ from the ‘File’ menu.
- Go to the Experiment Library. Find the document labeled as shown above. Double-click the document filename or select it and click OK or ‘Open’.

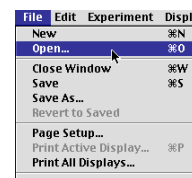

- The file opens with a Graph display. Data recording is set to one measurement per second.
- 3 Calibrate the Light Sensor using the penlight. Put clear water in the square bottle. Let the light transmitted through the clear water be “100% intensity”.

Sensor Calibration

1. Set the GAIN switch on the top of the Light Sensor to ‘1’.
2. Turn on the penlight. Make sure it is lined up with the Light Sensor.
3. In the Setup window, double-click the Light Sensor icon. **Result:** In *DataStudio*, the ‘Sensor Properties’ window opens. Click the ‘Calibrate’ tab. In *ScienceWorkshop*, the

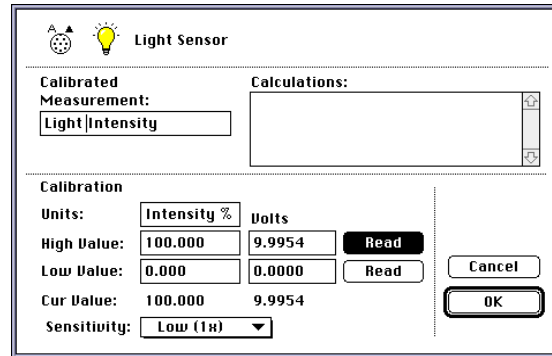
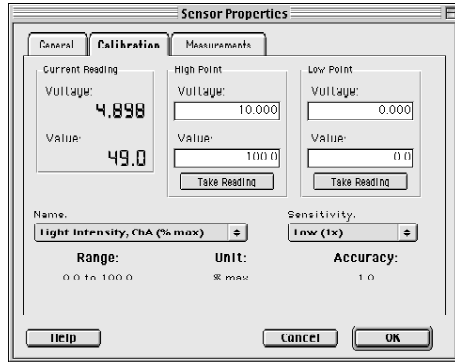

‘Sensor Setup’ window opens.

- The current value of the voltage from the Light Sensor appears under ‘Current Reading’ (in *DataStudio*) or next to ‘Cur Value’ (in *ScienceWorkshop*).
 - If the voltage reading is under 4.9 volts, calibrate the software. In *DataStudio*, click the ‘Take Reading’ button under the ‘High Point’ column. In *ScienceWorkshop*, click the ‘Read’ button at the right end of the ‘High Value’ row.
 - If the voltage reading is 4.9 volts or higher, move the penlight slightly farther away from the Light Sensor until the reading drops to 4.9 volts. Calibrate the software. In *DataStudio*, click the ‘Take Reading’ button under the ‘High Point’ column. In *ScienceWorkshop*, click the ‘Read’ button at the right end of the ‘High Value’ row.
4. Click ‘OK’ to return to the Experiment Setup window.

[] C. Do the Experiment

- For the first part of your data collecting, measure the turbidity of the water sample.
- For the second part of your data collecting, use the Light Sensor and pen light to measure the clarity of the water.

Turbidity



When you pour water from the beaker in to the cylinder, *be patient*. Pour slowly. The challenge is to find out how much water you need in order to block your view of the Secchi disk symbol below the cylinder.

When you can barely see the symbol through the water, stop for a moment. Let the water become still. If you can see any of the symbol through the water, slowly pour more water into the cylinder until you can’t see the Secchi disk symbol any more.

Remember to record the depth of the water at which you could no longer see the symbol.

Clarity

- Use a graduated cylinder to measure 100 mL of your water sample.
- The light shield blocks most of the room light from entering the Light Sensor so it measures the clarity of the water more accurately.



- To start data recording, click 'Start' () in *DataStudio* or 'REC' () in *ScienceWorkshop*.
- After data recording stops automatically, remove the box and the bottle, but leave the penlight "on". Empty and clean the square bottle.

Repeat the data recording process two more times.



- The procedure says to make the second water sample by adding 50 mL of clear water to 50 mL of your original water sample. When you dilute the first sample one-to-one with clear water, this dilutes the first sample to 50%.
- When you add 67 mL of clear water to 33 mL of your original water sample, this dilutes the original sample two-to-one so it is 33% as 'muddy' as the original.

[] D. Analyze the Data

1. Use the built-in statistics in the Table display to determine the average intensity of light that was transmitted through each sample of water.

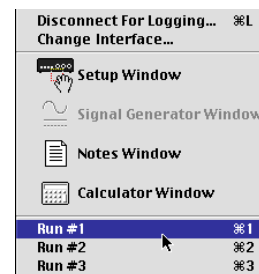
- In *DataStudio*, click 'Data' () in the Table toolbar to select a run of data. In *ScienceWorkshop*, click 'Data' () in the corner of the Table display or select a run of data the bottom of the Experiment menu.



- In *DataStudio*, click 'Statistics' () in the Table toolbar and select 'Mean'. In *ScienceWorkshop*, click 'Statistics' () in the corner of the Table and select 'Mean' from the 'Statistics Menu' ()
2. Record the 'Mean' values and write your conclusions and answer the questions in the Report.

Procedure Details — Activity S05: Reducing Turbidity in Water

This part of Appendix A gives information about how to use the Light Sensor to measure the change in the amount of light transmitted through water that is being clarified.



About the Light Sensor:

Note: See the description in *Appendix A: S04 - Clarity and Turbidity in Water*.

[] Pre-Lab: Collect the Sample

1. Use a container to collect about 2 liters of non-clear water from a river, lake or pond. Put a label on the container and mark the label with the location of the water source.
 - For example, tie a rope or cord to a bucket and lower the bucket into the water. Pour the water from the bucket into your container.

Alternate Procedure

- Add a small amount of dirt to 2 liters of water and shake vigorously to thoroughly mix the dirt and water. A little dirt goes a long way. Don't add too much, or the water will become too muddy.

[] A. Set Up the Equipment

1. In the lab, measure out 5 g of aluminum sulfate (alum), 2.5 g of iron chloride, and 2.5 g of calcium oxide (lime) onto individual weighing papers.
 - Use an accurate balance. Put a weighing paper onto the balance and find its weight. Then add the chemical to the weighing paper until the total weight on the balance is the specified amount above the weight of the paper.
2. Label the three plastic bottles. Label one bottle "CONTROL", a second bottle "ALUM", and a third bottle "IRON CHLORIDE + LIME".
 - Use the marking pen to write on each label, then attach the labels to the bottles.
3. Use a base and support rod, a lab stand rod, a multi-clamp (right-angle clamp), and two buret clamps to make a stand for the penlight and Light Sensor. Adjust the position of the penlight and the Light Sensor so the square bottle just fits between them. Line up the penlight and the sensor so the light goes in a straight line through the bottle to the sensor.
 - When the Light Sensor, bottle, and penlight are lined up, put strips of tape on the table to trace the position of the square bottle.
 - Mark the position of the bottle so you can put it in the same place each time you make a measurement.

NOTE: See the description and diagrams in *Appendix A: S04 - Clarity and Turbidity in Water*.

5. Use a cardboard box to make a "light shield" that can fit over the pen light, square bottle, and sensor.
 - Be very careful when cutting the cardboard box.

[] B. Set Up the Experiment

1. Connect the sensor to the interface.
2. Start *DataStudio* or *ScienceWorkshop* and open the file as follows:

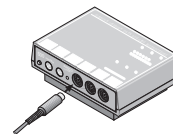

DataStudio	ScienceWorkshop (Mac)	ScienceWorkshop (Win)
S05 Turbidity.DS	S05 Turbidity	S05_TURB.SWS



- Select 'Open' from the 'File' menu.
 - Go to the Experiment Library. Find the document labeled as shown above. Double-click the document filename or select it and click OK or 'Open'.
- The file opens with a Digits display and a Table display. Data recording is set for one measurement per second and will stop automatically at 30 seconds.
3. Connect the Light Sensor DIN plug into Analog Channel A on the interface.
 4. Calibrate the Light Sensor using the penlight.

Sensor Calibration

NOTE: See the description in *Appendix A: S04 - Clarity and Turbidity in Water*.





[] C. Do the Experiment

- Shake each bottle before you make the first measurement. Shaking stirs up the sediment.

- To start data recording, click 'Start' () in *DataStudio* or 'REC' () in *ScienceWorkshop*.
- Let each bottle sit undisturbed for 30 minutes and then make the second measurement.
- Let each bottle sit undisturbed overnight and then make the last measurement.

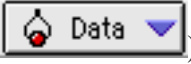
Be careful! The most important part of the procedure for the second and third measurement is to move the bottles without shaking up the sediment.

[] D. Analyze the Data

1. Use the built-in statistics in the Table display to determine the average intensity of light that was transmitted through each sample of water at each of the three times.
 - In *DataStudio*, click 'Data' () in the Table toolbar to select a run of data. In *ScienceWorkshop*, click 'Data' () in the corner of the Table display or select a run of data the bottom of the Experiment menu.
 - In *DataStudio*, click 'Statistics' () in the Table toolbar and select 'Mean'. In *ScienceWorkshop*, click 'Statistics' () in the corner of the Table and select 'Mean' from the 'Statistics Menu' ()
2. Record the 'Mean' values and write your conclusions and answer the questions in the Report.

Procedure Details — Activity S06: The pH of a Natural Water System

This part of Appendix A has information about how to collect water samples. It also gives information about how to calibrate and use the pH Sensor to measure the pH of samples of water collected from a stream.



About the pH Sensor

The pH Sensor is designed to measure the pH (“potential of hydrogen”) of a liquid.

The sensor has two parts: a pH Electrode and an Amplifier. The pH Electrode has a BNC plug on its cable that connects to the BNC connector on the Amplifier. The Amplifier has a DIN plug and a cable that connects to the interface.

The pH Electrode produces a voltage proportional to the hydrogen ion concentration (“potential of hydrogen” or pH) in a solution. The voltage changes 0.1 volts for each pH number. The pH Amplifier has a very high input impedance.

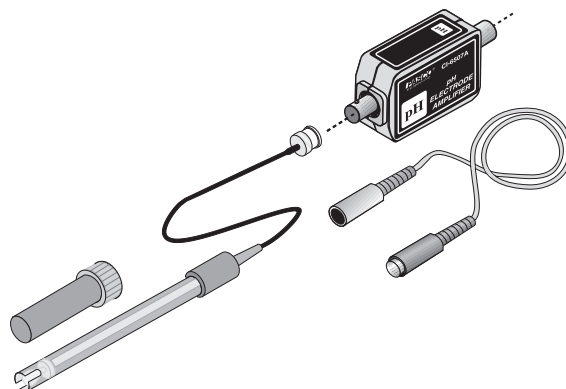

The end of the pH Electrode is stored in a small plastic container that contains a buffer solution made with 1 gram of potassium chloride (KCl) added to 100 mL of pH 4 buffer solution.

The software converts the voltage from the sensor into a digital (numeric) value of pH intensity. First, the sensor is calibrated to the pH value of a high pH buffer solution. Then the sensor is calibrated to a second pH value.

[] A. Set Up the Collecting Equipment

1. Before going to the stream, clean the sample bottles and rinse them with distilled water. Label each sample bottle.
 - Write on the label, and then put the label on the bottle.

[] B. Collect the Samples

1. At the collection site, remember to record the date, time, location, and weather.
2. Use the sampling pole to fill the container with water. Fill the container from a point as far from shore as possible.
 - Extend the sampling pole straight out over the water. Rotate the pole so the mouth of the collecting container points down.
 - Gently lower the bottle vertically into the water until the container is fully submerged.
 - Slowly rotate the sampling pole 90 degrees until the mouth of the container faces the current. Continue to rotate the container until the mouth points up and gently lift the container out of the water
 - Pour the water from the container into the first sample bottle. Repeat the previous steps for collecting water samples at four more sites.

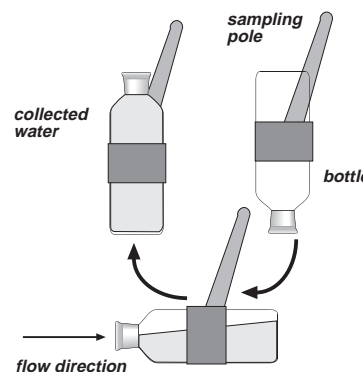

[] C. Set Up the Lab Equipment

- 1 Plug the DIN connector cable into the sensor's DIN plug and then connect the cable into Analog Channel A on the *ScienceWorkshop* interface.
2. Connect the pH electrode to the BNC port on the pH Sensor.
 - Line up the connector on the end of the cable with the pin on the BNC port.
 - Push the connector onto the port and then twist the connector clockwise about one-quarter turn until it clicks into place.
3. Set up the equipment to calibrate the pH Sensor. To calibrate the pH Sensor you will need the following: wash bottle, distilled water, three beakers, buffer solutions of high pH (e.g. pH 10) and low pH (e.g. pH 4), pH Sensor.
4. Put 100 mL of the high pH buffer solution in one beaker. Put 100 mL of the low pH buffer solution into a second beaker. Put 100 mL of distilled water into the third beaker. Put distilled water into the wash bottle.

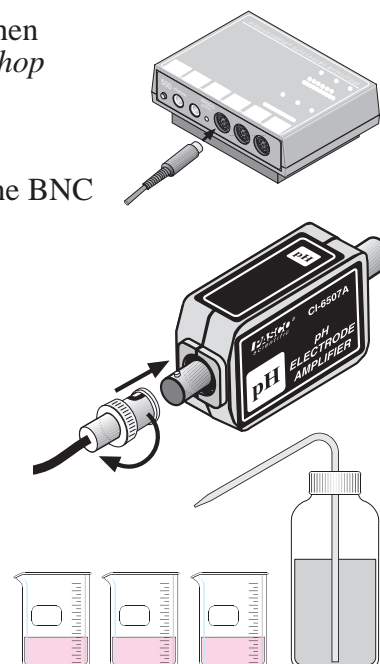

[] D. Set Up The Experiment

1. Start *DataStudio* or *ScienceWorkshop* and open the file as follows:

DataStudio	ScienceWorkshop (Mac)	ScienceWorkshop (Win)
S06 pH of a Stream.DS	S06 pH of Water	S06_PH.SWS

- Select 'Open' from the 'File' menu.
 - Go to the Experiment Library. Find the document labeled as shown above. Double-click the document filename or select it and click OK or 'Open'.
 - The file opens with a Digits display and a Table display. Data recording is set for one measurement per second and will stop automatically at 30 seconds.
2. Use the beakers, buffer solutions, and wash bottle to calibrate the pH Sensor.

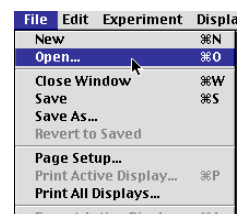

How to Calibrate the pH Sensor

1. Remove the pH electrode from its bottle of buffer solution. Make sure the pH electrode is connected to the sensor.
 2. Use the wash bottle to rinse the end of the electrode. Soak the pH electrode in the beaker of distilled water for 10 minutes.
 3. In the Experiment Setup window, double-click the pH Sensor icon.
- In *DataStudio*, the Sensor Properties window will open. Click the 'Calibration' tab. In *ScienceWorkshop*, the Sensor Setup window will open.

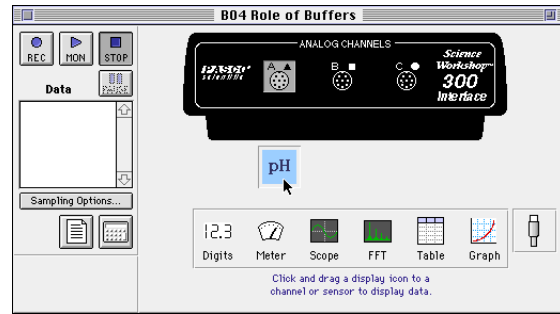
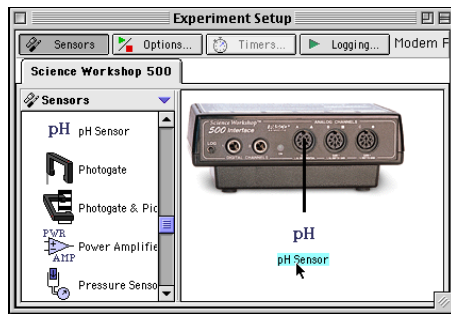
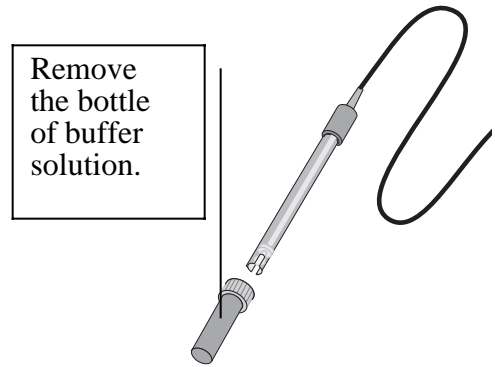

4. Calibrate with the high pH buffer solution.
5. Put the end of the pH electrode into the high pH buffer solution.
6. Check the voltage under 'Current Reading' in *DataStudio* or next to 'Cur Value:' in *ScienceWorkshop*.

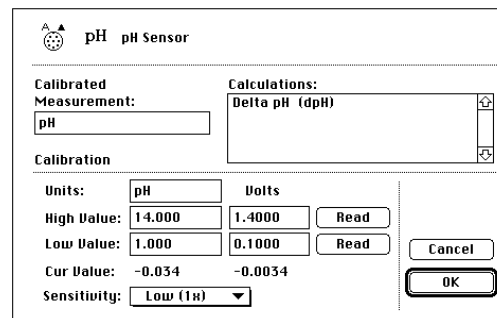
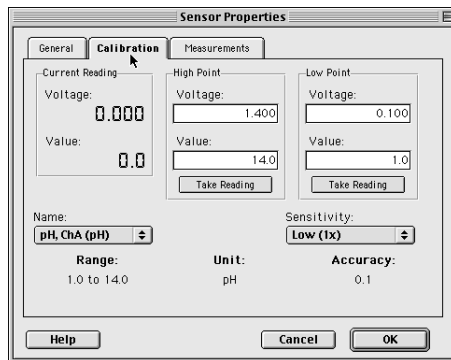

7. When the voltage stabilizes, click the 'Take Reading' button under 'High Point' in *DataStudio* or the 'Read' button in the row for 'High Value:' in *ScienceWorkshop*.
8. Enter the pH value of the buffer solution.
9. Thoroughly rinse the pH electrode with distilled water and dry it with a tissue.
10. Calibrate with the low pH buffer solution. Put the end of the pH electrode in the low pH buffer solution.
11. Check the voltage under 'Current Reading' in *DataStudio* or next to 'Cur Value:' in *ScienceWorkshop*.

- When the voltage stabilizes, click the 'Take Reading' button under 'Low Point' in *DataStudio* or the 'Read' button in the row for 'Low Value:' in *ScienceWorkshop*.
- Enter the pH value of the buffer solution. Click OK to return to the Experiment Setup window.
- Thoroughly rinse the pH electrode with distilled water and dry gently.



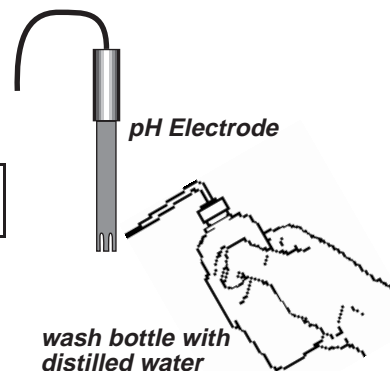

[] E. Do the Experiment

- To start recording data, click 'Start' in *DataStudio* or 'REC' in *ScienceWorkshop*.
- Gently swirl the pH electrode in the water.

- Be sure to rinse the pH electrode with distilled water between each sample.

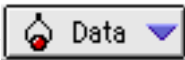

[] F. Analyze the Data

- Use the built-in statistics in the Table display to determine the average pH value of each sample of water.
 - In *DataStudio*, click 'Data' () in the Table toolbar to select a run of data. In *ScienceWorkshop*, click 'Data' () in the corner of the Table display or select a run of data the bottom of the Experiment menu.
 - In *DataStudio*, click 'Statistics' () in the Table toolbar and select 'Mean'. In *ScienceWorkshop*, click 'Statistics' () in the corner of the Table and select 'Mean' from the 'Statistics Menu' ().
- Record the average pH value of each sample in the Lab Report. Record your conclusion and answer the questions in the Report.

Procedure Details — Activity S07: Acid Rain

This part of Appendix A gives information about how to calibrate and use the pH Sensor to measure the pH of samples of water collected from a stream.



About the pH Sensor

NOTE: See the description in Appendix A: *S06 - pH of a Natural Water System*.

[] A. Set Up the Equipment

Overview

√ Make gas generators using Beral-type pipettes. Generate three different gases by adding a small amount of hydrochloric acid to the pipettes containing three different substances.

√ Use a long-stem pipette to transfer the gas produced in each generator to a test tube that has water and the pH Sensor in it. Use the pH Sensor to measure the change in pH as the water absorbs the gas.

[] Prepare the gas generators.

1. Label three *short-stem* Beral pipettes with the formula of the solid they will contain and label three *long-stem* Beral pipettes with the formula of the gas they will contain.

• You can store all six pipettes with the bulb end down in a small beaker until needed.

2. Use the *short-stem* pipettes to ‘suck up’ some of the powder into the pipette. Get the powder into the pipette until there is just enough powder to fill the curved end of the bulb of the pipette when you hold the pipette with the bulb end down (see the diagram).

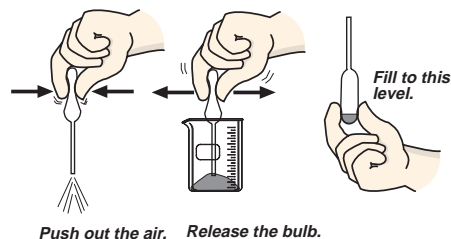

3. Generate the gas. Get a Beral pipette with 1.0 Molar hydrochloric acid (HCl) from your teacher.

SAFETY ALERT!

HCl is a strong acid. Hold the pipette gently, with the stem pointing up, so that HCl drops do not escape.

- Use the pipette with the hydrochloric acid to add about 20 drops of HCl solution to the powdered substances in the short-stem pipettes. Gently swirl the pipette that contains NaHCO₃ and HCl.
- After you swirl the pipette to mix the NaHCO₃ and HCl, you may see some gas bubbles. Because each gas is more dense than air, it will tend to stay inside the gas generator pipette.

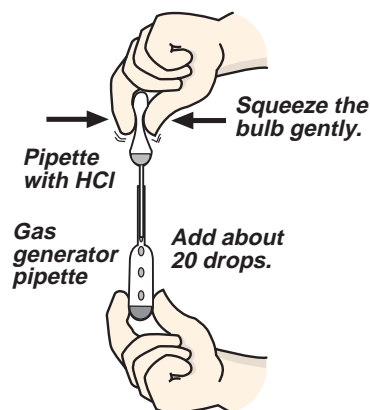

[] Set up the pH Sensor

- Use a clamp to mount the test tube to the support rod. Add about 4 mL of tap water to the test tube. Rinse the pH electrode with distilled water and place the electrode into the tap water in the test tube.

• NOTE: Make sure that the bottom of the electrode is in the tap water. Add more water if needed.

- Position the pH electrode to one side of the test tube so there is enough room for you to insert a long-stem pipette down into the water.

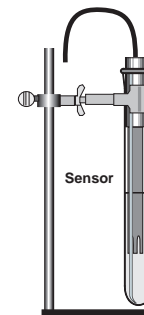

[] Collect the gas

- The basic idea is transfer gas from each generator pipette to a long-stem pipette.
- Squeeze all of the air from the bulb of the first long-stem pipette. Keep the bulb completely collapsed and insert the long stem of the pipette down into the first gas-generating pipette. The tip of the long-stem pipette should not touch the liquid in the gas generator pipette (see the diagram).
- Release the pressure on the bulb so that it draws gas up into it. Store the long-stem pipette and the gas generator pipette bulb down in the 100 mL beaker.

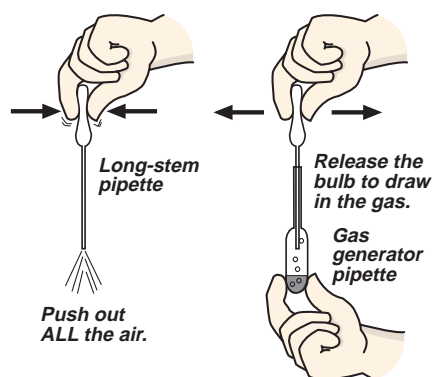

[] B. Set Up the Experiment

1. Connect the sensor to the interface. Start *DataStudio* or *ScienceWorkshop* and open the file as follows:

DataStudio	ScienceWorkshop (Mac)	ScienceWorkshop (Win)
S07 Acid Rain.DS	S07 Acid Rain	S07_RAIN.SWS

- Select 'Open' from the 'File' menu.
 - Go to the Experiment Library. Find the document labeled as shown above. Double-click the document filename or select it and click OK or 'Open'.
 - The file opens with a Digits display and a Table display. Data recording is set for one measurement per second and will stop automatically at 30 seconds.
2. Use the beakers, buffer solutions, and wash bottle to calibrate the pH Sensor.

NOTE: See the description in Appendix A: *S06 - pH of a Natural Water System*.

[] C. Do the Experiment

1. To start recording data, click 'Start' in *DataStudio* or 'REC' in *ScienceWorkshop*. Data recording stops automatically at 100 seconds.
 2. When you insert each long-stem pipette into the test tube alongside the pH electrode, make sure that the tip of the pipette is below the bottom of the electrode (see the diagram).
- Try to put the long-stem pipette into the test tube without squeezing any gas out of the bulb.
3. Remember to try to push all of the gas out of the bulb of the pipette. Use both hands. Squeeze slowly so that bubbles of gas have time to be absorbed in the water.



[] D. Analyze the Data

1. Use the built-in statistics in the Table display to determine the minimum pH value and maximum pH value for the water for each gas.
 2. Calculate the change in pH. Record the values in the Lab Report.
- In *DataStudio*, click 'Statistics' in the Table toolbar. Minimum and Maximum are already selected. In *ScienceWorkshop*, click 'Statistics' in the corner of the Table and select 'Minimum' and 'Maximum' from the 'Statistics Menu'.
3. Answer the questions in the Lab Report.

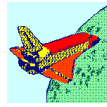

Memorandum — About the Mission to Other Worlds

Greetings,

The activities in this part of Earth Science Labs with Computers focus on an imaginary journey to another planet – a *Mission to Other Worlds*. You will do a series of tasks related to landing a spacecraft on another planet and exploring the planetary surface. You will make scientific measurements and report your results to a fictional character that is a Space Agency administrator.

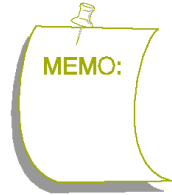

Background

Humankind began sending robot spacecraft to other worlds in the 1960's. Humans first walked on the moon in July, 1969. Although humans have not yet walked on another planet, robot spacecraft such as the Mars Pathfinder Lander and the earlier Viking I and II Landers have done the next best thing — sent back pictures and data from the surface of Mars.

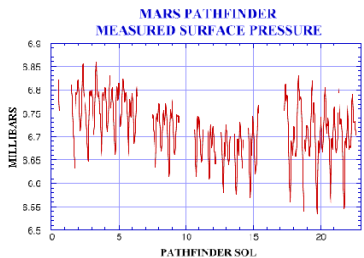

Data from Mars
Pathfinder Lander

←
Panoramic view
showing Martian
terrain and the
Sojourner Rover.
→

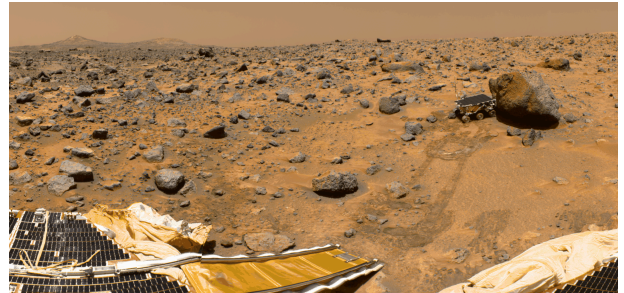

Activity Descriptions

Some of the activities in the *Mission to Other Worlds* (MTOW) part of Earth Science Labs with Computers are related to the task of designing, building, testing, launching, and landing a spacecraft. Other activities are related to the task of exploring a planetary terrain.



Some activities are best done in a lab or classroom. Others are designed to be done out-of-doors. Two of the lab/classroom activities use some collected samples.

LAB = Activity for the lab or classroom

FIELD = Activity to be done out-of-doors

COLLECT = Activity using collected samples

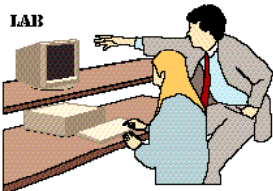
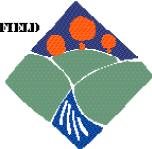

No.	List of Activities by Type	Type
M01 M03 M04 M05 M06 M09 M10	Design and Construct a Model Rocket Determine a Spacecraft Surface – Heat Transfer Map a Planetary Terrain Acceleration of a Falling Object Design Landing Bags pH of Samples from Other Worlds Test for Life: Measure a Chemical Reaction	LAB 
M02 M07 M08	Acceleration of a Model Rocket Temperature at Different Locations Relative Humidity	FIELD 
M09	pH of Samples from Other Worlds	COLLECT 

Description

Each **LAB** activity in the *Mission to Other Worlds* part of *Earth Science Labs with Computers* has three parts: *Memorandum*, *Procedure Outline*, and *Report*.

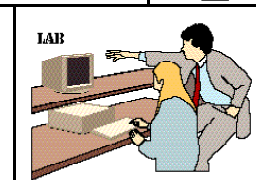

The *Memorandum* from the Space Agency administrator explains the task for each activity.

The *Procedure Outline* has general suggestions for performing the task. The outline includes the following parts:

• Equipment List	• Consumables List	• Purpose	• Hypothesis
• Background	• Safety Reminders	• Procedure Ideas	• Analysis Ideas

If you have questions that the *Procedure Outline* can't answer, you can refer to the more detailed information in the *Technical Manual* section (*Appendix B*).

The *Report* is where you record your results and write your conclusion.

Each **FIELD** activity involves making measurements and recording observations and data away from the classroom. You will use the “data logging” feature of the *ScienceWorkshop 500* Interface. The *ScienceWorkshop 500* Interface can operate on batteries. Refer to *Appendix C* for more information about using the *ScienceWorkshop 500* Interface for data logging.

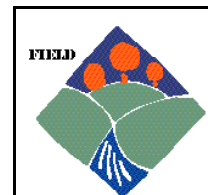

The **COLLECT** activity starts with collecting various samples. The rest of the activity is done in the lab or classroom using the *ScienceWorkshop* program and interface.



Teacher's Guide Notes – About the Mission to Other Worlds

Goal

The goal is to involve each student in creative role-playing and problem solving while they are learning fundamental science concepts and skills. They will make predictions, observe phenomena, record measurements, modify parameters, and draw conclusions. In other words, they will “do science”.

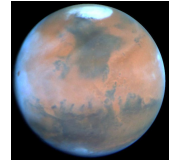

Teacher's Role

The teacher's role is “project manager”. The fictional character that is the Space Agency administrator asks the team of student researchers to submit their reports to you — the project manager — for evaluation. In some activities, you will provide samples for your “research teams” (student groups) to investigate. In every activity, you will be the safety officer, the guide, and the resource person.

Activity Descriptions

The activities in the *Mission to Other Worlds (MTOW)* part of Earth Science Labs with Computers are similar to the tasks performed by scientists and engineers at space agencies around the world. Some activities involve designing, building, testing, launching, and landing a spacecraft. Other activities are related to exploring a planetary surface and testing for evidence of life.

Teacher's Guide Description – Part 2

As in Part 1, the pages in the Teacher's Guide for Part 2 are the same as the pages in the Student Workbook. However, the Teacher's Guide contains typical answers to the questions in the *Report* section, and includes a *Teacher's Notes* section with time estimates, objectives, tips, and sample data.

Appendix B provides details of the procedure for each activity, such as how to calibrate a sensor, if needed. Appendix C describes how to use the *ScienceWorkshop 500* Interface for “data logging”

The next page is a preparation information summary for the activities in Part 2.



Preparation Information Summary

The following is a summary of information about each activity.

Teacher's Guide Preparation Summary — Part 2



- Type: Type of activity, C = Collect, F = Field, L = Lab
- Pre-lab: Does the activity require preparation before the day of the activity?
- Cal.: Calibration of sensor(s)
- Prep. Time: Estimate of preparation time on the day of the activity
- Act. Time: Estimate of activity time
- Other: Miscellaneous reminders

No.	Title	Type	Pre-lab	Cal.	Prep. Time	Act. Time	Other
M01	Design and Construct a Model Rocket	L	gather materials	no	2 hrs	3 days	note 2
M02	Acceleration of a Model Rocket	F	safety, role playing, review data logging	no	15 min	45 min	
M03	Determine a Space Craft Surface	L	safety	no	15 min	30 min	note 3
M04	Map a Planetary Surface	L	safety, Motion Sensor tutorial	no	15 min	30 min	
M05	Acceleration of a Falling Object	L	review calibration	yes	15 min	30 min	
M06	Design Landing Bags	L	Keyboard Sampling	no	15 min	15 min	
M07	Temperature at Different Locations	F	review data logging	no	15 min	30 min	
M08	Relative Humidity	F	room temp. water	no	15 min	30 min	
M09	pH of Samples from Other Worlds	C	collect samples	yes	15 min	30 min	
M10	Test for Life: Measure a Chemical Reaction	L	prepare "soil" samples	no	1 hr	30 min	

Notes

2. Students can begin collecting materials weeks in advance.
3. Room temperature water is needed.



Memorandum – Activity M01: Design and Construct a Model Rocket

To: Space Research Team
From: Joe Venus, Space Agency Administrator
Date: 12 Sep. 2017 A.D.

Greetings,

Allow me to introduce myself. My name is Joe Venus and I am the Space Agency administrator for the *Mission to Other Worlds* project. Your team has been selected to perform several scientific activities related to our project. Congratulations!

Your scientific research will help us to determine the best methods and materials to use for the upcoming mission. It is important to make the most accurate measurements possible, to carefully record your data, and to make a thorough report of your results. I have the highest confidence in you.

Your first task is to design and construct a model rocket.

You will use your model in upcoming activities to determine its maximum acceleration and to test different materials that are under consideration for the hull of the spacecraft.

The next section of this Workbook is the *Procedure Outline* for this activity. It will give you some ideas, but, as always, if you can improve on the methods or materials, please do so. Remember, read and heed the *Safety Reminders* in the outline.

Refer to the *Technical Manual* in *Appendix B* of this Workbook for more detailed information on the tasks for this project.

I look forward to seeing your reports for the tasks related to this project. Please submit your reports to the project manager so the manager can forward them to me.

Thank you for your efforts. Good luck on the activities.

Yours,

Joe Venus
Space Agency Administrator

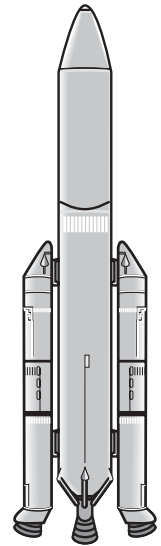

Procedure Outline – Activity M01: Design and Construct a Model Rocket

This is a LAB activity.

Equipment	Qty	Consumables	Qty
Construction tools	-	Construction materials	-
Per Student	Qty		
Protective gear	1 set		

VOCABULARY	drag	stability	thrust	weight
-------------------	------	-----------	--------	--------

What Do You Think

What things increase or decrease the amount of drag on a rocket when it is in a planet's atmosphere? What things increase or decrease the amount of stability of a rocket? What must be true about the thrust of a rocket compared to its weight?



Take time to answer the 'What Do You Think?' question(s) in the Lab Report section.

Background

Imagine a rocket on a launching pad, ready for take-off. The countdown goes to "Zero — Ignition", and the engines roar to life. In order for the rocket to leave the pad, the **thrust** of the engines must be greater than the **weight** of the rocket.

As the rocket climbs through the atmosphere, its weight *decreases* because the engines burn fuel and send the hot gases at great speed out through the exhaust nozzles. The rocket accelerates to faster and faster speeds. At the same time, the air resistance, or **drag**, *increases* because the rocket has to push more and more air out of the way as it goes faster and faster. For the ascending portion of the flight, the thrust must be greater than the sum of the weight and the drag. Eventually the rocket gets above the thickest layers of the atmosphere, and the drag decreases.

The rocket needs **stability** in order to stay on course as it goes up. It has several ways to maintain stability. During the ascending portion of the flight, it has powerful gyroscopes to help keep it on course. In orbit, it can use attitude control jets to adjust its motion. During descent and landing, a spacecraft such as the Space Shuttle relies on the delta-shaped wings and vertical stabilizer to control the motion.

Model Rocket

Your model rocket must have enough thrust to overcome its weight. It needs to have maximum stability and minimum drag.

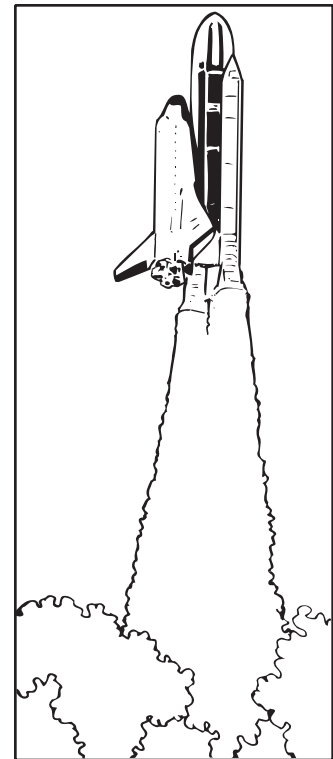

<p>SAFETY REMINDERS</p> <ul style="list-style-type: none"> • Use all construction tools carefully. Be particularly cautious with knives, scissors, and other sharp tools. • Wear protective gear while using the construction tools. 		<p>THINK SAFETY ACT SAFELY BE SAFE!</p>
---	--	--

Procedure Outline

1. Create a design for your model rocket.
2. Carefully draw and label a sketch of your design and seek approval for your design from the project manager.
3. Modify the design as needed based on the manager's recommendations and, once the final design is approved, construct your model.
4. Include a sketch of your final design in your report to the administrator.
5. Answer the questions in the Report.

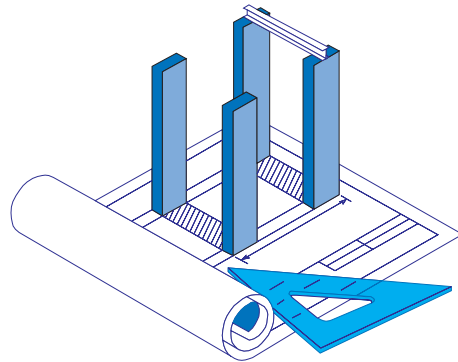

[✓] Remember, for more detailed information see Appendix B

Report – Activity M01: Design and Construct a Model Rocket

NAME _____
CLASS _____
DATE _____

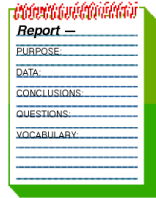

[] What Do You Think?

What things increase or decrease the amount of drag on a rocket when it is in a planet's atmosphere? What things increase or decrease the amount of stability of a rocket? What must be true about the thrust of a rocket compared to its weight?



Answers will vary. See the answers to the questions.

[] Rocket Design

1. Include a detailed sketch of your final design for your model rocket. (Attach extra sheets if necessary.)

[] Questions

1. What things increase or decrease the amount of drag on a rocket when it is in a planet's atmosphere?

Answers will vary. One thing that increases the amount of drag on a rocket when it is a planet's atmosphere is the resistance of the atmosphere. One thing that decreases the amount of drag is a streamline shape for the rocket.

2. What things increase or decrease the amount of stability of a rocket?

Answers will vary. One thing that increases the stability of a rocket is the length. The longer the rocket, the more stable it tends to be. Fins also increase stability. One thing that decreases the stability is an imbalance in the distribution of mass.

3. What must be true about the thrust of a rocket compared to its weight?

Answers will vary. The thrust of the rocket must be greater than the weight..

Complete the following:

VOCABULARY

drag: Drag is anything that hinders the motion of something.

stability: Stability is a measure of how stable or balanced something is.

thrust: Forward force produced (as in a rocket) by the high speed jet of fluid discharged rearward.

weight: Weight is the measure of the force of gravity on an object. It is proportional to the object's mass.

Submit this report to your project manager as soon as possible so it can be forwarded to the Space Agency administrator.

Teacher's Notes – Activity M01: Design and Construct a Model Rocket

The following is a list of suggested materials and tools for constructing a model rocket.

Suggested Materials	Qty	Equipment and Tools	Qty
cardboard sheets, approx. 21 by 28 cm	1 or 2	pencil or pen	1
cardboard tube*, approx. 60 cm long	1	ruler or straight-edge	1
glue	1 tube	scissors	1 pr
newspaper, sheet	several		
plastic sheet, thin, approx. 30 by 30 cm	1	<i>Optional</i>	
plastic soda bottle**	1	<i>hot glue gun</i>	
string	4 m	<i>paint</i>	
tape	1 roll	<i>paint brush or sprayer</i>	

*The cardboard tube can be smaller in diameter than the plastic soda bottle.

**The plastic soda bottle should be between 500 mL and 2 L.

Time Estimates	Preparation: 2 hours	Activity: several hours
-----------------------	-----------------------------	--------------------------------

Objectives

Students will be able to...

- design and build a simple model rocket
- describe the relationship between the thrust of a model rocket and the weight of the rocket

Notes

Pre-lab: Gathering Materials

Talk to your students about the materials needed for this activity a few weeks in advance of when you plan to begin the activity. You may wish to ask for volunteers to get specific items, and give each volunteer a materials checklist to help them remember. Perhaps you can put a poster on a wall that shows the number of each item needed, how many have been collected, and how many days remain to the beginning of the activity (see the last page). Give a team of students the responsibility of checking on the materials and marking progress on the poster.

Organization

Students tend to be enthusiastic about model building. It promotes creative thinking. It's challenging and fun. In this case, it culminates in a hands-on outdoor activity.

Harness the student energy. Organize your students into teams with various responsibilities: gathering materials, record-keeping, managing the construction tools, and clean-up after construction.

Safety During Construction

Safety is a primary concern both during construction of the model rockets and later during the launch. You probably have your own classroom rules for using scissors, knives, or other tools. Perhaps you can assign a different student each day to recite the safety rules regarding construction tools.

<p>SAFETY REMINDERS</p> <ul style="list-style-type: none"> • Use all construction tools carefully. Be particularly cautious with knives, scissors, and other sharp tools. 	<p>THINK SAFETY ACT SAFELY BE SAFE!</p>
---	--

Construction Notes

The section of the Technical Manual (*see Appendix B*) for this activity gives ideas for constructing an engine, fins, body, and parachute from a plastic soda bottle, cardboard sheet, cardboard tube, and plastic sheet.

Model Rocket Launcher

A Bottle Rocket Launcher (Model P4-2000) is available from *Arbor Scientific* for about \$20. The launcher is manufactured by *The Science Source*.

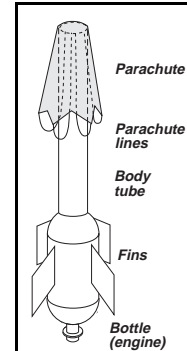

Arbor Scientific P.O. Box 2750 Ann Arbor, MI 48106-2750 (800) 367-6695	The Science Source P.O. Box 727 Waldoboro, ME 04572 (207) 832-6344
---	---

The Bottle Rocket Launcher from Arbor Scientific is a ready-to-use launcher with a rubber stopper that fits into the neck of a plastic bottle. The rubber stopper is attached to an air hose that connects to a bicycle tire pump. The air hose has a Schrader-type bicycle tire valve at the end. The launcher has metal jaws that hold the neck of the bottle. A locking bar keeps the metal jaws in place until it's time to launch. A trigger line pulls out the locking bar to release the rocket.

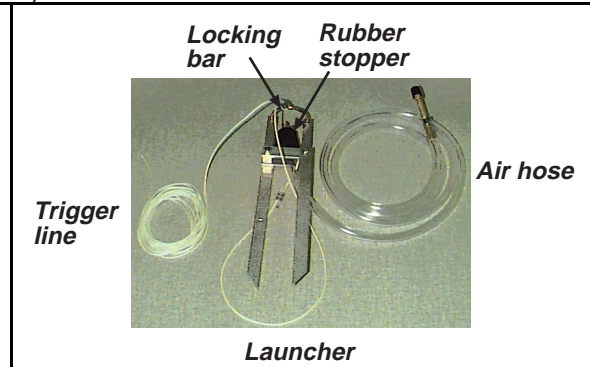

The launcher legs are pushed into the ground to support the launcher. The instructions suggest that you use three dowels or sticks to help support the plastic bottle.

The air hose is about 2 meters long and the trigger line is about 4 meters long.

Materials Checklist and 'Countdown to Launch' Poster

This type of activity can generate a lot of interest. Students tend to be eager to participate. Some time before the activity begins, you may want to post a 'Materials Checklist' for each class with the items and quantity needed. Another idea is to display a 'Days to Beginning of Construction' or a 'Countdown to Launch' calendar. Perhaps members of each class could volunteer to check in and store the materials that students bring to class.

Class _____		
Activity M01: Design and Construct a Model Rocket		
I. Materials Checklist	Number Needed	Number Collected
A. Plastic soda bottles		
B. Cardboard tubes		
C. Plastic garbage bags		
D. Cardboard sheets		
II. Days to Beginning of Construction		



Memorandum – Activity M02: Acceleration of a Model Rocket

To: Space Research Team
From: Joe Venus, Space Agency Administrator
Date: 05 Oct. 2017 AD

Greetings,

First, thank you for the reports on your model rocket construction. The project manager forwarded the reports to me, and they were impressive. Keep up the good work.

Your next task is to test a critical performance feature of your model rocket design – the *acceleration*.

The acceleration of an object is a measurement of the rate at which it changes velocity – the speed and/or direction of motion.

We know from previous missions into space that humans cannot perform their tasks if the acceleration is too great. Your task is to measure the acceleration of your model rocket during launch.

The next section of this Workbook is the *Procedure Outline* for this activity. It will give you some ideas, but, as always, if you can improve on the methods or materials, please do so. Remember, read and heed the *Safety Reminders* in the outline.

Refer to the *Technical Manual* in *Appendix B* of this Workbook for more detailed information on this task.

I look forward to seeing your reports for this activity. Information about the acceleration of the model rocket is vital to the engineers who are designing our spacecraft. Please submit your reports to the project manager so the manager can forward them to me.

Again, thank you for your efforts. Good luck on the next phase of the project.

Yours,

Joe Venus
Space Agency Administrator

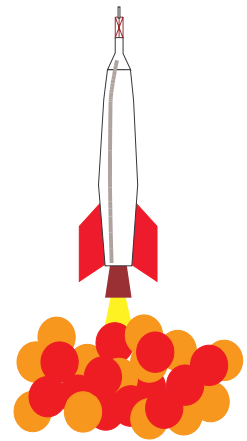
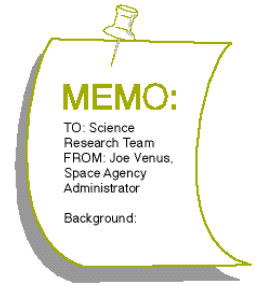

Procedure Outline – Activity M02: Acceleration of a Model Rocket

This is a FIELD activity that uses the *ScienceWorkshop* 500 Interface for data logging.

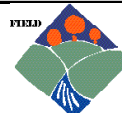

Equipment		Per Team	Qty
Per Class	Qty	Container, 2 L (for carrying water)	2
ScienceWorkshop™ 500 Interface	1	Model rocket	1
Motion Sensor (CI-6742)	1	Per Student	
Air pump (e.g., bicycle tire pump)	1	Safety goggles	1 pr
Base & Support Rod (ME-9355)	1	Consumables	
Dowels or sticks	6	Cardboard sheet (splash shield)	1
Model rocket launcher	1	Tape	1 roll
Tire pressure gauge	1	Water	3 L

VOCABULARY	acceleration	mass	net force	velocity
-------------------	--------------	------	-----------	----------

What Do You Think?

What is the acceleration of your model rocket at launch? What happens to the acceleration if less water is pressurized in the engine? What happens to the acceleration if more water is pressurized in the engine?



Take time to answer the 'What Do You Think?' question(s) in the Lab Report section.

Background

The speed and direction of motion of an object is its **velocity**. Whenever an object changes its velocity, it undergoes acceleration. One way to describe **acceleration** is to say that it is a measure of the rate of change of velocity. What causes acceleration?

A force is a push or a pull. The **net force** on an object is the combination of all the pushes and pulls on the object.

The net force on an object causes its acceleration. The more the net force, the more the acceleration. The less the net force, the less the acceleration. Therefore, the net force on an object is one of the things that determines how much acceleration the object has.

A basic property of every object is the other thing that determines how much acceleration there is. That basic property is the object's mass. The **mass** of an object is the amount of matter in the object.

The mass of an object determines how much resistance the object has to the net force that is applied to it. In other words, when a net force is applied to an object, the more mass it has, the less the acceleration. The less the mass the object has, the more the acceleration it will have.

This is a **FIELD** activity. You will use a Motion Sensor to measure how fast your model rocket is accelerating when it leaves the launch pad.

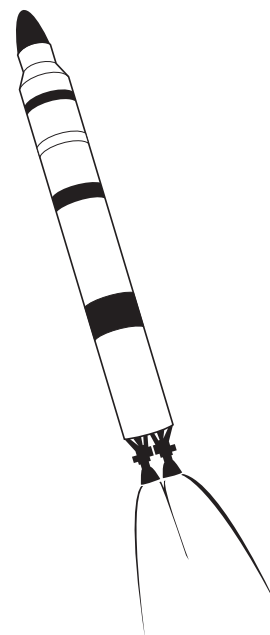

SAFETY REMINDERS

- Wear protective goggles.
- Place the launcher securely into the ground.
- Do not pressurize the model rocket beyond 40 pounds per square inch.
- Do not aim the rocket at anyone, or at buildings or other structures.
- Do not look down at the rocket during pressurization or launch.

**THINK SAFETY
ACT SAFELY
BE SAFE!**



Procedure Outline

[✓] Remember, for more detailed information see **Appendix B**.

In this activity, use the Motion Sensor to measure the change in motion of your model rocket as it leaves the launch pad. For the first trial, use a standard amount of water in the engine (bottle). For the second trial, reduce the amount of water, but pressurize the bottle to the same pressure as for the first trial. For the third trial, increase the amount of water but keep the pressure the same.



[] **A. Set Up the Equipment**

1. Fill the 2 liter containers with water.
2. Get ready to carry the water containers and other equipment (air pump, base and support rod, model rocket & launcher, tire pressure gauge) to the launch site.

[] **B. Set Up the Experiment**

You can use the *ScienceWorkshop 500* Interface to record data outside of a classroom. You can program the interface while it is connected to the computer, disconnect the interface and go collect data, and then re-connect the interface to the computer to analyze your data.

See Appendix C for detailed information about how to use the *ScienceWorkshop 500* Interface for “data logging”

1. Start *DataStudio* or *ScienceWorkshop* and open the file as follows:

DataStudio	ScienceWorkshop (Mac)	ScienceWorkshop (Win)
M02 Model Rocket.DS	M02 Acceleration	M02_ACCE.SWS

- The file opens with a Graph display. The Trigger Rate for the Motion Sensor is set to 50 Hz (50 samples per second).
2. In the software, prepare the interface for data logging. (*See Appendix C.*)
 3. Disconnect the interface from the computer and power supply.
 4. Carry the equipment, interface, and Motion Sensor to the launch site.

[] **C. Do the Experiment**

- For the first trial, fill the bottle half full of water and pressurize to 40 pounds per square inch (p.s.i.) with the air pump.
- For the second trial, fill the bottle less than half full of water and pressurize to 40 p.s.i.
- For the third trial, fill the bottle more than half full of water and pressurize to 40 p.s.i.

1. Connect the Motion Sensor plugs into Digital Channel 1 and Digital Channel 2 on the interface box. Mount the Motion Sensor on the support rod.
2. Put the launcher legs securely into the ground. Add water to the bottle. Push the rubber stopper into the bottle neck and set up your model rocket on the launcher.
3. Set the Motion Sensor and interface about 1 meter from the launch site. Aim the Motion Sensor so that its "line-of-sight" is at the top of the model rocket.
4. Make a curved splash shield and put it between the base of the launcher and the Motion Sensor to protect the sensor from water.
5. Connect the air hose valve stem to your air pump. Pressurize the bottle to 40 pounds per square inch and prepare to launch the rocket.

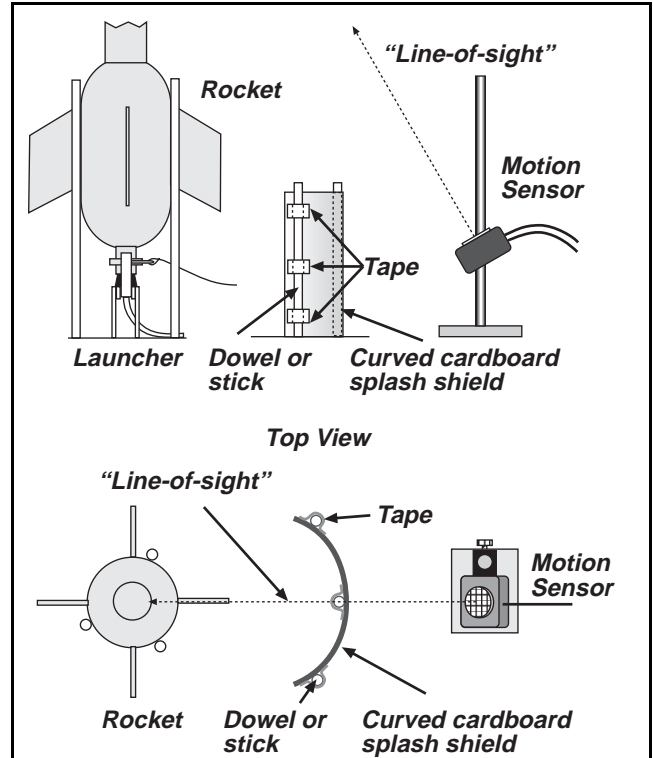

6. When you are ready, press the LOG button on the front of the interface. Wait ten seconds.
7. When the green light-emitting diode on the front of the interface begins blinking rapidly, tug sharply on the trigger line to launch the rocket.
8. After the rocket launches, press the LOG button on the front of the interface to stop data recording.
9. Recover the model rocket and repeat the launch procedure, but use *less* water than for the first trial. Recover the model rocket and repeat the launch procedure, but use *more* water than for the first trial.

[] D. Analyze the Data

1. Reconnect the interface to the power supply and computer. In the software, download the data from the interface to the computer. (See Appendix C.)
2. Examine each run of data in the Graph display to determine the acceleration of your model rocket.
3. Record your results and answer the questions in the Report.

Report – Activity M02: Acceleration of a Model Rocket

NAME _____
CLASS _____
DATE _____

Report –
PURPOSE: _____
DATA: _____
CONCLUSIONS: _____
QUESTIONS: _____
VOCABULARY: _____

[] What Do You Think?

What is the acceleration of your model rocket at launch? What happens to the acceleration if less water is pressurized in the engine? What happens to the acceleration if more water is pressurized in the engine?

Answers will vary. Students may predict that the acceleration will be greater if more water is pressurized.

[] Analyze the Data

- Use the Graph display to see how much the velocity changes for each trial. [Refer to Appendix B for more information about using the Statistics that are part of the Graph display.]
- For each of the three trials, sketch the change in velocity.

This is an example of the plot of velocity versus time for a model rocket.

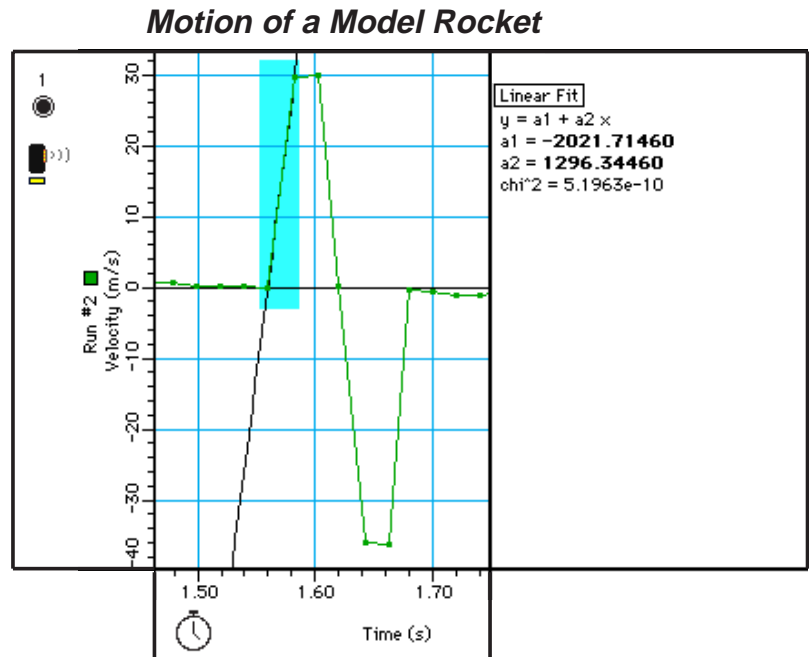

[] Conclusion

Answers will vary. One conclusion is that the acceleration of the model rocket is difficult to measure! Another conclusion is that the changes in the amount of water used in the engine did not make a measurable change in the acceleration.

[] Questions

1. How do your answers to the 'What Do You Think?' questions compare with the results?

Answers will vary. _____

2. In this activity, which combination of water and pressurized air caused the most acceleration?

Answers will vary. The acceleration of the model rocket is dependent on more factors than just the combination of water and pressurized air in the engine. However, we found that the original combination caused the most acceleration.

3. Which combination of water and pressurized air caused the least acceleration?

Answers will vary. The combination of less water and the same pressure caused the least acceleration. Although the overall weight of the rocket was reduced, so was the amount of thrust.

Complete the following:

VOCABULARY

acceleration: Acceleration is the change in velocity of an object.

mass: Mass is the amount of matter in an object. It is a measure of the object's inertia.

net force: Net force is the sum of all the forces acting on an object.

velocity: Velocity is the speed and direction of motion of an object.

Optional

If one "g" is 9.8 m/sec^2 , how many "g"s did your model rocket have?

Answers will vary. The data in the sample above give an acceleration of over 120 g's!

Submit this report to your project manager as soon as possible so it can be forwarded to the Space Agency administrator.

Teacher's Notes – Activity M02: Acceleration of a Model Rocket

Time Estimates	Preparation: 15 min	Activity: 45 min
-----------------------	----------------------------	-------------------------

Objectives

Students will be able to...

- use a Motion Sensor to measure the motion of a model rocket during launch
- interpret a graph of a model rocket's motion to determine its acceleration during launch

Notes

Safety

First, remind students about *safety*. Please require them to wear protective goggles at launch.

SAFETY REMINDERS

- Wear protective goggles.
- Place the launcher securely into the ground.
- Do not pressurize the model rocket beyond 40 pounds per square inch.
- Do not aim the rocket at anyone, or at buildings or other structures.
- Do not look down at the rocket during pressurization or launch.



Role Playing

This activity is an opportunity for student role-playing. For example, each team of students could select members of their team for the following roles:

√Team Flight Director — responsible for checking that all systems are “go” and for pulling the trigger line.

√Operations Officer — responsible for filling the engine with water, setting up the team's model rocket on the launcher, and pressurizing the system.

√Tracking Systems Officer — responsible for aligning the Motion Sensor so it is “aimed” at the top of the model rocket before launch.

√Launch Officer — responsible for pressing the LOG button on the interface and announcing the countdown to launch.

If the team plans to launch their model rocket more than one time, they can rotate responsibilities. For example, the Operations Officer for Launch #1 might be the *Backup* Team Flight Director for Launch #1, and would serve as Team Flight Director for Launch #2, and so on.

In addition, members from the class could be assigned other tasks:

√Launch Managers — responsible for getting the launch equipment (e.g., launcher, dowels, air pump) from the classroom to the launch site and for setting up the launcher and splash shield.

√Safety Officers — responsible for reminding all launch personnel about the safety rules.

√Launch Recorders — responsible for recording the order of launch so that each run of data can be matched up with the correct team.

√Recovery Teams — responsible for recovery of the model rockets after launch.



Preparation for Launch

The following is a summary of how to prepare the model rocket for launch.

- Turn the rocket so the neck of the bottle is up. Half fill the bottle with water.
- Put the end of the air hose through the base of the launcher between the arms. Press the rubber stopper firmly into the neck of the bottle. Place the rubber stopper and bottle between the arms of the launcher.
- Each arm of the launcher has a notch in its side. Move the arms so that each notch fits over the neck ring of the bottle. When the arms are in place, put the ends of the locking bar into the holes on the launcher arms.
- Take the launcher and rocket to an appropriate launch site. Press the two pointed legs of the launcher into the ground to anchor the launcher in place.
- Push three dowels or sticks into the ground at equal intervals of distance around the side of the rocket to support the rocket.
- Attach the valve stem on the end of the air hose to the bicycle tire pump.
- Pump up the air pressure inside the bottle to 40 pounds per square inch, but no more!

Set Up the Motion Sensor

- Mount the Motion Sensor on the support rod.
- Set the Motion Sensor and interface about 1 meter from the launch site.
- Aim the Motion Sensor so that its "line-of-sight" is at the top of the model rocket.
- One way to line up the Motion Sensor is to look at the brass-colored transducer on the front of the sensor. If you can see the reflection of your eye, then you know where the sensor's "line-of-sight" is located.
- If you can see the top of the rocket and your eye in the reflection from the transducer, then the line of sight of the sensor is at the top of the rocket.

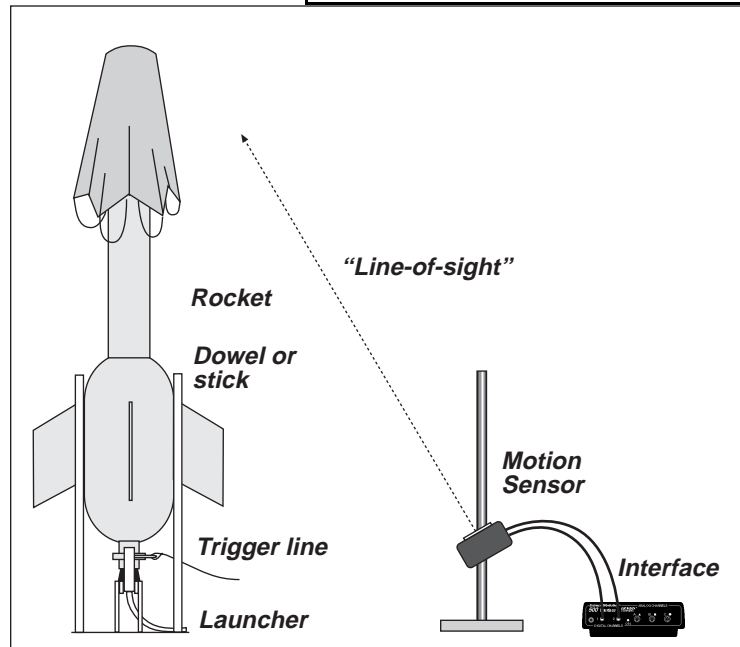
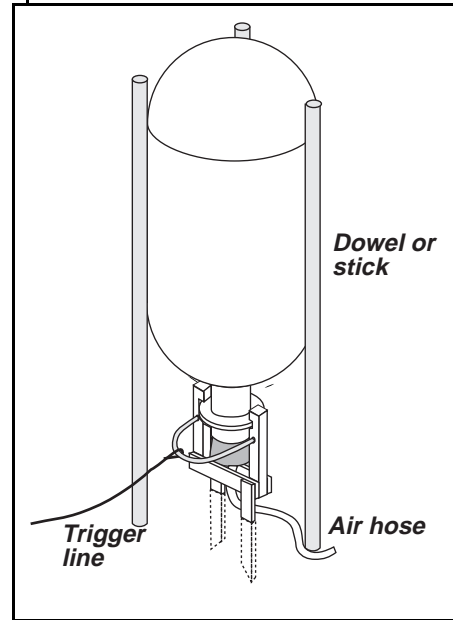
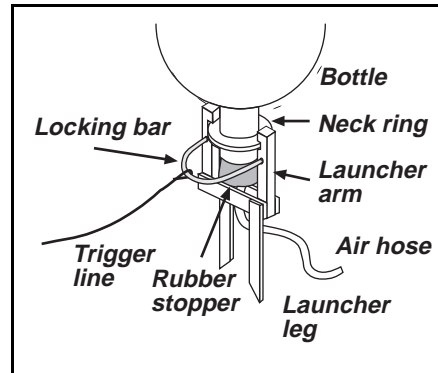

- Put a piece of cardboard as a “splash shield” between the launcher and the Motion Sensor to keep the sensor from getting wet. You can make a splash shield from a single sheet of cardboard (21 by 28 cm), some tape, and three dowels or sticks.

Launch

- Discuss the way you want the launch to go *before* the students go to the launch site.
- Establish rules about where participants and observers are to stand relative to the launch site.
- Warn the “launch personnel” that they may get sprayed by water as it shoots from the end of the rocket.

Extensions

Students can measure the effect of different levels of air pressure on the model rocket's altitude. Another extension is to keep the amount of air pressure constant, but vary the amount of water.

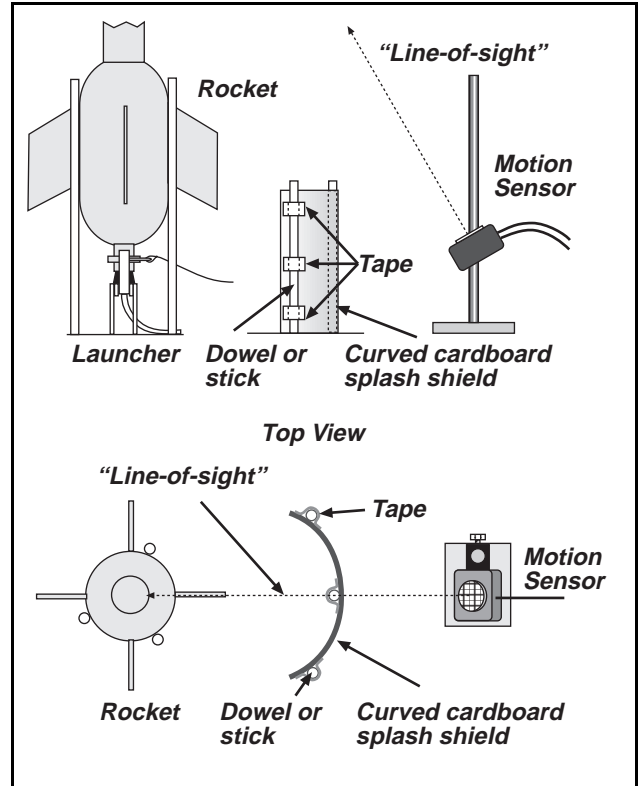



Memorandum – Activity M03: Determine a Spacecraft Surface - Heat Transfer

To: Space Research Team
From: Joe Venus, Space Agency Administrator
Date: 25 Oct. 2017 AD

Greetings,

First, thank you for the reports on the acceleration of your model rockets. The project manager forwarded the reports to me, and I just finished reviewing them. Your results are very important to the design engineers.

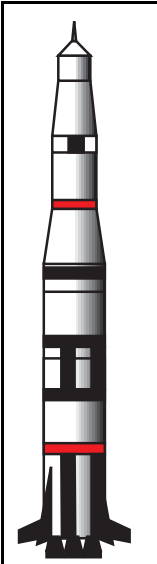
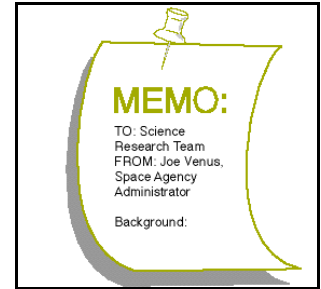

The next task deals with the surface of our spacecraft. The design engineers plan to use aluminum metal because it is light, strong, and inexpensive. They need to know what will happen to the temperature of storage tanks and other equipment that is just inside the surface of the spacecraft.

The water storage tanks and some of the other equipment inside the spacecraft must be kept warm. The engineers want to know whether a dark colored aluminum surface can absorb enough radiant energy from the sun to keep the tanks and other items warm inside.

The liquid oxygen and liquid hydrogen tanks need to be kept cold. The engineers want to know whether a shiny aluminum surface can reflect enough radiant energy from the sun to keep the fuel tanks cold inside.

The next section of this Workbook is the *Procedure Outline* for this activity. It will give you some ideas, but, as always, if you can improve on the methods or materials, please do so. Remember, read and heed the *Safety Reminders* in the outline.

Refer to the *Technical Manual* in *Appendix B* of this Workbook for more detailed information on this task.

I look forward to seeing your reports for this activity. Information about the change in temperature for a shiny surface versus a dark-colored surface is vital to the engineers who are designing our spacecraft. Please submit your reports to the project manager so the manager can forward them to me.

Again, thank you for your efforts. Good luck.

Yours,

Joe Venus
Space Agency Administrator

Procedure Outline – Activity M03: Determine a Spacecraft Surface - Heat Transfer

This is a LAB activity.



Equipment	Qty	Consumables	Qty
Temperature Sensor (CI-6505A)	2	Water	1 L
Aluminum can, black (TD-8570A)	1		
Aluminum can, shiny (TD-8570A)	1	<i>Per Student</i>	Qty
Graduated cylinder, 100 mL	1	Protective gear	1 set
Heat lamp	1		
Ruler or Metric tape (SE-8712A)	1		
Thermal insulation pad	2		

VOCABULARY	conduction	convection	heat	radiation
------------	------------	------------	------	-----------

What Do You Think?

What is the change in temperature of a shiny, unpainted aluminum can compared to the change in temperature of a dark-colored aluminum can when both are exposed to a source of radiant energy?



Take time to answer the 'What Do You Think?' question(s) in the Lab Report section.

Background

Heat is thermal energy in transit. Heat transfer happens when two objects are at different temperatures.

Heat is transferred in three ways: **conduction**, **convection**, and **radiation**. When an aluminum can full of hot water sits in a room, the water transfers heat to the room by all three methods. Heat is transferred by conduction through the sides of the can because air molecules make direct contact with the can. Air molecules that become warm by conduction carry thermal energy with them as they “bounce” their way upward from the can. This is heat transfer by convection. Finally, a small amount of thermal energy leaves in the form of electromagnetic waves that are emitted from the can’s surface. This is heat transfer by radiation.

If an aluminum can full of room temperature water is exposed to a heat lamp, the can will absorb radiant energy. When an object absorbs radiant energy, its temperature usually rises. Some surfaces are able to absorb radiant energy better than others.

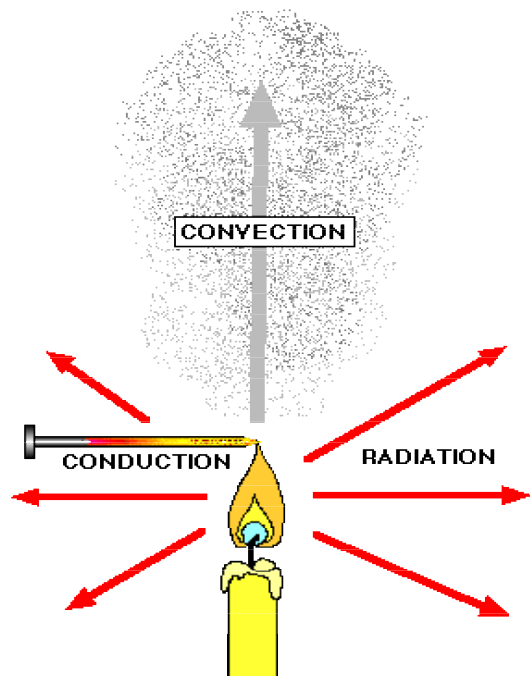

This is a **LAB** activity. You will use Temperature Sensors to measure the rate of change of temperature for water in two different aluminum cans exposed to a heat lamp.

SAFETY REMINDERS (LAB)

- Wear protective gear while handling hot objects.
- Follow directions for using the equipment.



Procedure Outline

[✓] Remember, for more detailed information see *Appendix B*.

In this activity, use two Temperature Sensors to measure the change in temperature of equal amounts of water in two different aluminum cans as the cans are warmed by a heat lamp.



[] **A. Set Up the Equipment**

1. Prepare the two aluminum cans (one shiny and one painted black). Fill each can with the same amount of room temperature water.
2. Place each can on an insulated pad. Keep the cans away from drafts.
3. Plug in the heat lamp but don't turn it on yet. Place each can so it is the same distance from the front of the heat lamp.
4. Connect one Temperature Sensor into Analog Channel A on the interface. Connect the second Temperature Sensor into Analog Channel B on the interface.
5. Put Temperature Sensor A into the shiny can and put Temperature Sensor B into the dark can.

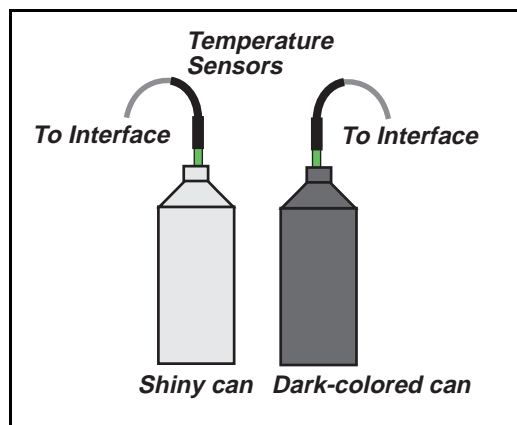

[] **B. SET UP THE EXPERIMENT**

1. Connect the sensor to the interface.
2. Start *DataStudio* or *ScienceWorkshop* and open the file as follows:

DataStudio	ScienceWorkshop (Mac)	ScienceWorkshop (Win)
M03 Heat Transfer.DS	M03 Heat Transfer	M03_HEAT.SWS

[] **C. Do the Equipment**

1. Turn on the heat lamp. Be sure that both cans receive the same amount of radiant energy.
2. Begin recording data. Data points will appear on the Graph display every 10 seconds.
3. Stir the water in both cans continuously for 15 minutes. Data recording stops automatically.

[] **D. Analyze the Data**

1. Examine the Graph display to find the minimum and maximum temperature for each can.
2. Record the minimum and maximum temperatures and calculate the change in temperature for each can.
3. Record your results and answer the questions in the Report.

Report – Activity M03 : Determine a Spacecraft Surface – Heat Transfer

Report –
 PURPOSE: _____
 DATA: _____
 CONCLUSIONS: _____
 QUESTIONS: _____
 VOCABULARY: _____

NAME _____
 CLASS _____
 DATE _____

[] What Do You Think?

What is the change in temperature of a shiny, unpainted aluminum can compared to the change in temperature of a dark-colored aluminum can when both are exposed to a source of radiant energy?

Answers will vary. Students may predict that the temperature of the black can will change more than the temperature of the shiny, unpainted can.

[] Analyze the Data

- Use the Graph display to see how much the temperature changes for the water in each can. [Refer to Appendix B for more information about using the Statistics that are part of the Graph display.] Record the results.

Can	Maximum temperature	Minimum temperature	Change in temperature
Shiny	25.0 °C	21.2 °C	3.8 °C
Black	35.6 °C	20.9 °C	14.7 °C

- For each Temperature Sensor, sketch the change in temperature.

This is an example of the plots of temperature versus time for the shiny can and the black can.

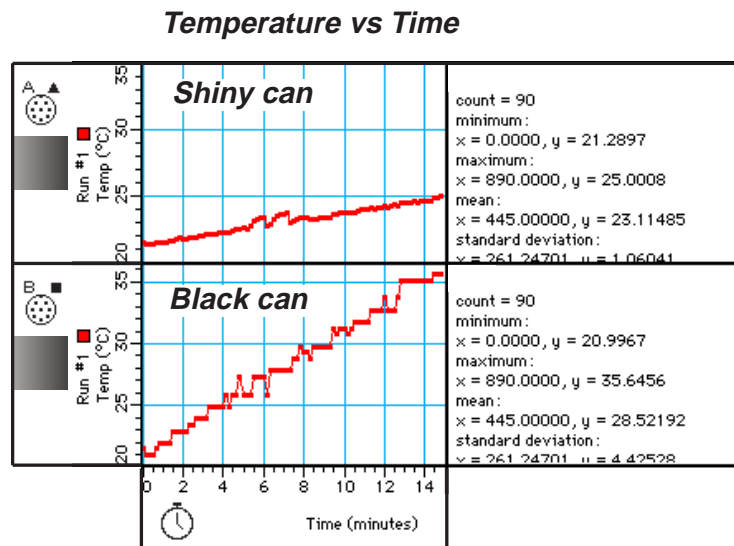

[] Conclusion

Answers will vary. One conclusion is that the temperature of the black can changes much more than the temperature of the shiny can when both are exposed to a heat lamp.

[] Questions

1. How does your answer to the 'What Do You Think?' questions compare with the results?

Answers will vary.

2. In this activity, which can of water had the greatest change in temperature?

In this activity, the black can of water had the greatest change in temperature.

3. Which can of water had the smallest change in temperature?

The shiny can of water had the smallest change in temperature.

4. Which kind of surface (dark or shiny) should be used on those parts of the spacecraft that must stay cool inside?

Based on the results in this activity, the shiny surface should be used on those parts of the spacecraft that must stay cool inside.

Complete the following:

VOCABULARY

conduction: Conduction is a method of thermal energy transfer where energy is transferred by direct contact.

convection: Convection is a method of thermal energy transfer where energy is carried by a fluid (such as a liquid or gas).

heat: Heat is the transfer of thermal energy.

radiation: Radiation is a method of thermal energy transfer where energy is transferred in the form of electromagnetic waves.

Submit this report to your project manager as soon as possible so it can be forwarded to the Space Agency administrator.

Teacher's Notes – Activity M03: Determine a Spacecraft Surface

Time Estimates	Preparation: 15 min	Activity: 30 min
-----------------------	----------------------------	-------------------------

Objectives

Students will be able to...

- use Temperature Sensors to measure the change in temperature of equal quantities of water inside aluminum cans with different surfaces
- describe which surface (shiny or black) absorbs radiant energy to cause the greatest change in temperature

Notes

This is a **LAB** activity that involves a heat lamp. Please review safety procedures.

Safety

First, remind students about *safety*. Please require them to wear protective goggles. (Heat lamp bulbs can break. Hot water might spill and scald someone.)

SAFETY REMINDERS (LAB)

- Wear protective gear while handling hot objects.
- Follow directions for using the equipment.



Setup

You may want to discuss “control” and “variable” before students begin the setup. Temperature and quantity of water are two of the controls in this activity. The surface of the cans is a variable.

The water used to fill the cans does not have to be exactly at room temperature. However, the water in each can must be the same temperature, and each can must be filled to the same level.

Another important control is the distance from the heat lamp to each can. Challenge your students to be as precise as possible in placing the two cans so they are same distance from the heat lamp.

Data Recording

Data recording stops automatically at 15 minutes. Students need to concentrate on swirling the water in the cans during that time. Stirring with the sensors is better than moving the cans to swirl the water.

Data Analysis

In addition to using the Graph display, students can also use the Table display to find the difference between the minimum and maximum temperature of the water in each can.

Click the **Display** menu and select **New Table**.

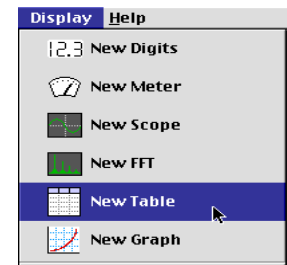

Click the Statistics button () to open the statistics area at the bottom of the Table.

Extension

Repeat the procedure, but begin with equal quantities of hot (80 °C) water in each can. Let the cans cool (i.e., don't use the heat lamp). Determine which of the cans *cools* faster.

Repeat the procedure with hot water in each can, but place a fan at an equal distance from each can. Turn on the fan so it sends air over each can. Determine whether the moving air changes the *rate* of cooling.

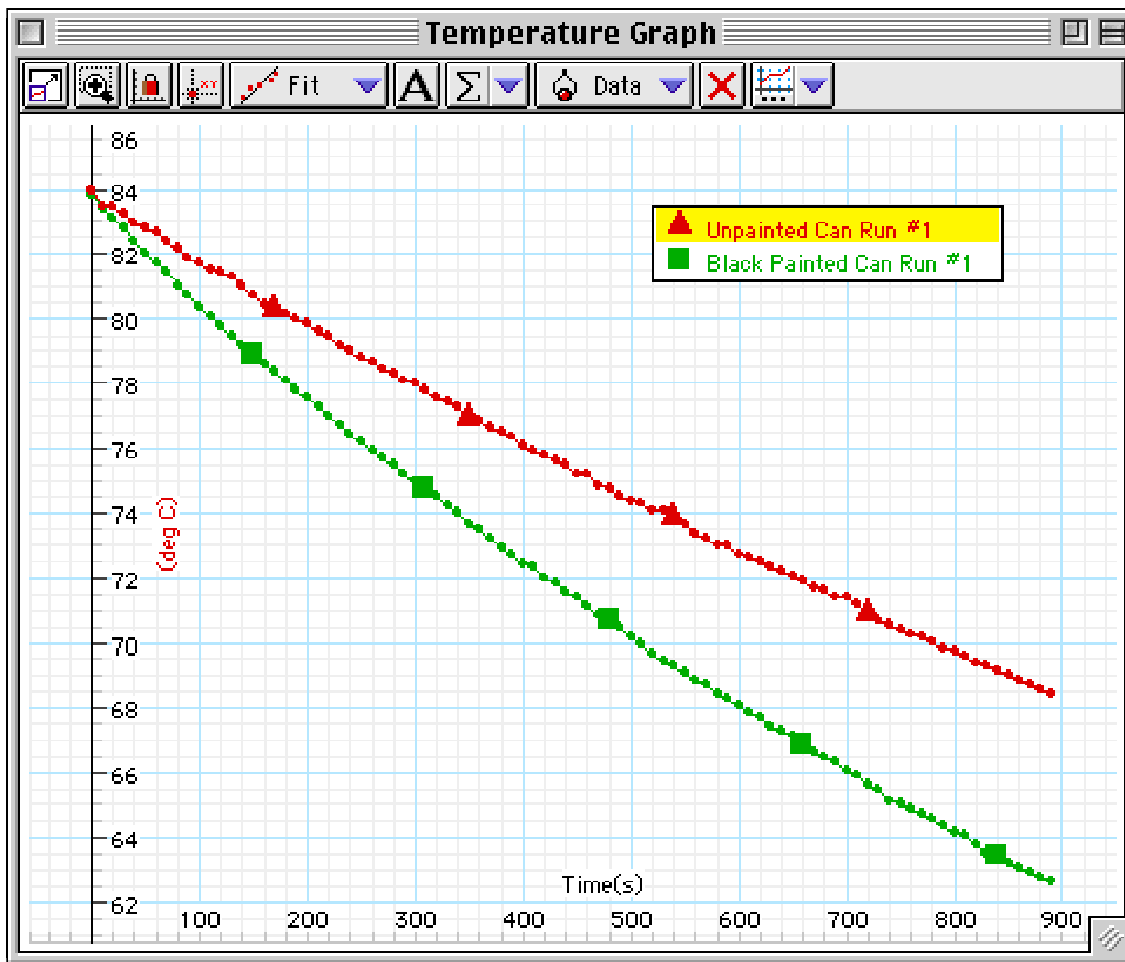



Memorandum – Activity M04: Map a Planetary Surface

To: Space Research Team
From: Joe Venus, Space Agency Administrator
Date: 30 Oct. 2017 AD

Greetings,

Your work in determining the spacecraft surface was outstanding. The project manager forwarded the reports to me, and I sent a summary of your valuable results to the design team. Thanks again.

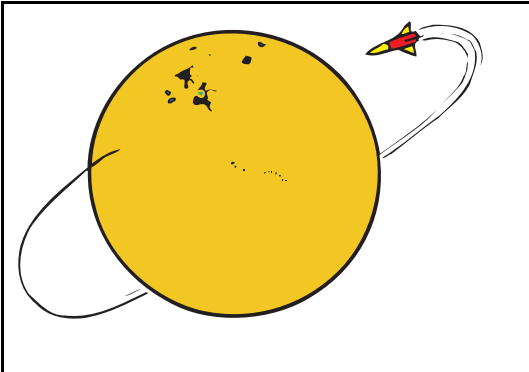
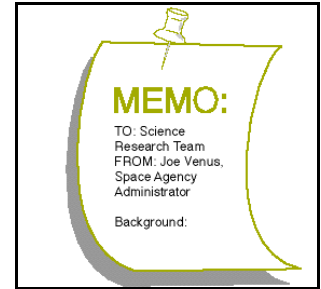

We are ready to tackle a new part of the project. The next few tasks all deal with planning the very difficult entry, descent, and landing phase of our mission to another world.

The first task is to test a method for mapping a planetary surface. A map of a planet's surface is essential in determining where to land our spacecraft.

The flight director intends to use a type of altimeter that is similar to the one on the Mars Pathfinder Lander. The altimeter determines the distance from the spacecraft to the planet's surface as the spacecraft orbits the planet.

As the spacecraft maintains a constant speed in a circular orbit, the altimeter device sends pulses of ultrasound down to the surface and records the echoes that bounce back from the terrain below. The on-board computer calculates the relative distance from the spacecraft to the surface features.

A plot of the relative distances can give us a good idea of the roughness of the surface.

The next section of this Workbook is the *Procedure Outline* for this activity. It will give you some ideas, but, as always, if you can improve on the methods or materials, please do so. Remember, read and heed the *Safety Reminders* in the outline.

Refer to the *Technical Manual* in *Appendix B* of this Workbook for more detailed information on this task.

Please submit your reports to the project manager so the manager can forward them to me. I look forward to reading them. I will give your results on planetary mapping to the flight director and other project planners.

Your hard work is appreciated. Good luck.

Yours,

Joe Venus
Space Agency Administrator

Procedure Outline – Activity M04: Map a Planetary Surface

This is a **LAB** activity that uses the 'data logging' feature of the interface.



Equipment Needed	Qty	Other	Qty
<i>ScienceWorkshop</i> TM 500 Interface	1	Miscellaneous objects	4-5
Motion Sensor (CI-6742)	1	Tape measure (optional)	1

VOCABULARY	altimeter	altitude	elevation	terrain
------------	-----------	----------	-----------	---------

What Do You Think?

How can a Motion Sensor be used to map the **elevation** of the surface features of a planet?



Take time to answer the 'What Do You Think?' question(s) in the Lab Report section.

Background

The Mars Pathfinder spacecraft used a laser altimeter to determine its height (altitude) above the surface of the planet Mars. A similar type of instrument on board the Mission to Other Worlds spacecraft will measure the altitude of surface features as the spacecraft orbits the planet it visits. Both instruments use a method of distance measurement that is somewhat like the distance measurement method used by the Motion Sensor and the *ScienceWorkshop* interface.

About the Motion Sensor

The Motion Sensor sends out a burst of ultrasonic pulses and senses the echoes of ultrasound that bounce back from objects in front of it.

The software program records the round-trip time and calculates the distance to the object.

You can plot the distance to an object on a graph. If the Motion Sensor is used to measure the distance from the sensor to the features on a model planetary surface, the plot of distance on the graph is a map of the elevation of the surface features on the planet.

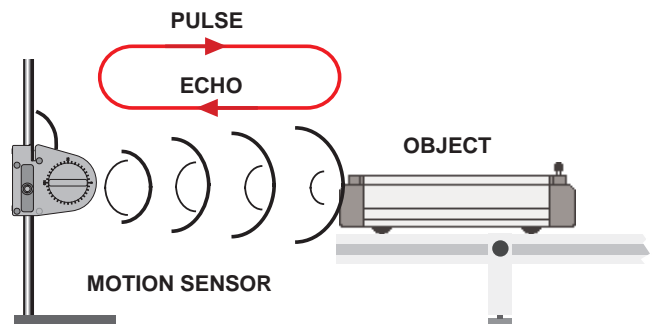

When a spacecraft in orbit around a planet measures the elevation of surface features, the spacecraft maintains a nearly circular orbit. This insures that the spacecraft is at a constant distance from the center of the planet, and moves with a constant speed. The challenge in this activity is to carry the Motion Sensor along a straight line at a constant speed.

This is a **LAB** activity. You will use the *ScienceWorkshop* 500 Interface for data logging.

SAFETY REMINDERS

- Follow directions carefully when using the equipment for this activity.

**THINK SAFETY
ACT SAFELY
BE SAFE!**

Procedure Outline

[✓] Remember, for more detailed information see Appendix B.

In this activity, carry the Motion Sensor and the *ScienceWorkshop* 500 Interface along a straight line at a constant speed over a model of a planetary surface. Use the sensor to measure the distance for each feature on the surface below it.



[] A. Set Up the Equipment

Create a model “planetary” surface using chairs, books, tables (even people) arranged in a row on a flat horizontal surface. Make sure that the person carrying the Motion Sensor can move through the landscape in such a way that the Motion Sensor can measure the distance from itself to the “features” on the surface.

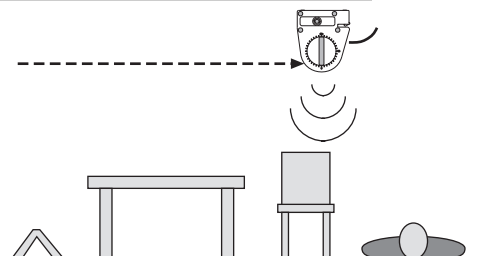

[] B. Set Up the Experiment

Use the *ScienceWorkshop* 500 Interface to record data with the interface disconnected from the computer. You can program the interface while it is connected to the computer, disconnect the interface and go collect data, and then re-connect the interface to the computer to analyze your data.

See Appendix C about using the *ScienceWorkshop* 500 Interface for “data logging”

1. Connect the sensor to the interface. Start *DataStudio* or *ScienceWorkshop* and open the file as follows:

DataStudio	ScienceWorkshop (Mac)	ScienceWorkshop (Win)
M04 Map a Planet.DS	M04 Map a Planet	M04_MAP.SWS

- The file opens with a Graph display. The file has a pre-made calculation for distance from the sensor to the planetary “surface”.
2. In the program, prepare the interface to be disconnected for data logging. (*See Appendix C.*) Then disconnect the interface from the computer and power supply.

[] C. Do the Experiment

1. Carry the interface and Motion Sensor to the edge of the “planet”. Hold the Motion Sensor about 1.5 meters (5 feet) above the floor. Turn the sensor so it faces the floor.
2. Press the LOG button on the interface to “wake” the interface and begin recording data.
 - The green light-emitting diode (LED) will blink once per second for ten seconds while the interface gets ready to record data. Recording starts when the green LED blinks rapidly.
3. Move at a slow, constant speed so the Motion Sensor can record the distance between it and the features of the “planet”.
4. When you reach the end of the landscape, press the LOG button again to stop recording data and return the interface to “sleep” mode. (The green LED blink once every five seconds.)

[] D. ANALYZE THE DATA

1. Reconnect the interface to the power supply and computer. Download the data from the interface to the computer. (*See Appendix C.*)
2. Use the Graph display to find the minimum, maximum, and mean values for the distances to the planet’s surface features. Record your results and answer the questions in the Report.

Report – Activity M04: Map a Planetary Surface

NAME _____
CLASS _____
DATE _____



[] What Do You Think?

How can a Motion Sensor be used to map the **elevation** of the surface features of a planet?

Answers will vary. Students may predict that the Motion Sensor can be used as an altimeter that sends out pulses of ultrasound and receives the echoes from the surface features.

[] Analyze the Data

- Use the Graph display in to see how much the distance from the sensor to the planetary “surface” changes as the Motion Sensor is carried over the “surface” along a straight line at constant speed. [Refer to Appendix B for more information about using the Statistics that are part of the Graph display.] Record the results.

Item	Minimum	Maximum	Mean
Distance	0.40 m	2.10 m	0.61 m

- Sketch the terrain of your planetary “surface”.

This is an example of a map of elevations of several “surface features” on a “planetary terrain”. Note that the altitude of the Motion Sensor is 2.1 meters instead of the recommended 1.5 meters.

“This surface has several tall peaks that extend above the average height (0.61 m) of the terrain. It also has a deep valley that appears to have a peak in middle - somewhat like a mid-ocean ridge. The mid-valley peak reaches just above the average height of the terrain. The feature at the right is below the average height of the terrain.”

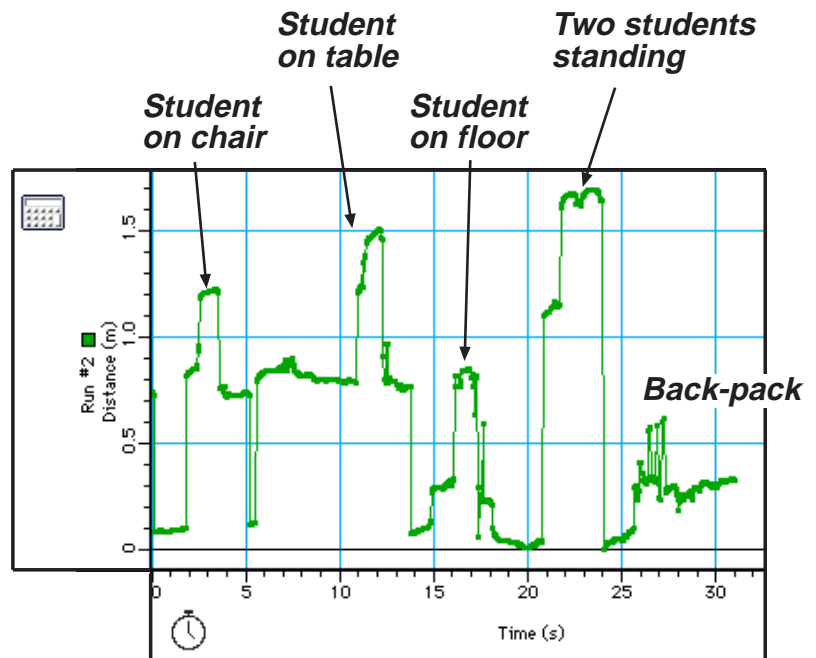

Map a Planetary Surface

[] Question

1. How can a Motion Sensor be used to map the elevation of the surface features of a planet?
Answers will vary. The Motion Sensor measures the distance from it to the objects that are set up as surface features on a model of a planet. If the distance to each object is subtracted from the height of the Motion Sensor, a plot of distance shows a map of elevation of the surface features.

Complete the following:

VOCABULARY
altimeter: An altimeter is a device used to measure altitude.
altitude: Altitude is vertical elevation.
elevation: Elevation is the height to which something is raised.
terrain: The terrain is the tract of ground considered with reference to its surface features.

Submit this report to your project manager as soon as possible so it can be forwarded to the Space Agency administrator.

Teacher's Notes – Activity M04: Map A Planetary Surface

Time Estimates	Preparation: 10 min	Activity: 30 min
-----------------------	----------------------------	-------------------------

Objectives

Students will be able to...

- use a Motion Sensor to measure distances from the sensor to objects arranged to model a planetary surface
- use the 'data logging' feature of the software and interface
- analyze the graph of data to determine the minimum and maximum distances from the sensor to the 'planetary surface'
- describe the overall shape of the planetary surface based on their data

Notes

The Motion Sensor can be hand-carried if the interface is disconnected from the computer for 'data logging'.

Alternate Setup

The Motion Sensor can be mounted on a horizontal rod that is supported at a fixed height above the 'planetary features'. Instead of carrying the sensor, have the students move the sensor at a constant speed along the horizontal rod.

Changing the 'Default' Distance in the Calculation

Measure the actual distance from the sensor to the surface upon which the 'planetary features' are arranged. Enter this distance into the calculation in the software.

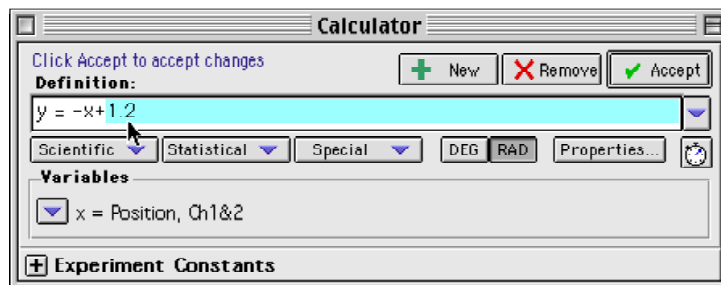

- In *DataStudio*, click the 'Calculate' button ( Calculate) to open the Calculator window. Change the distance and then click 'Accept'.

- In *ScienceWorkshop*, click the 'Calculator' button () in the Experiment Setup window. Change

the distance and then click the 'Equals' key () on the keypad.

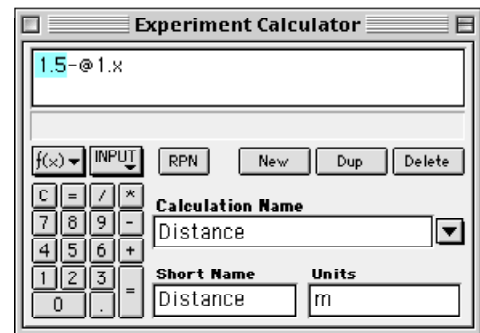

Sample Data

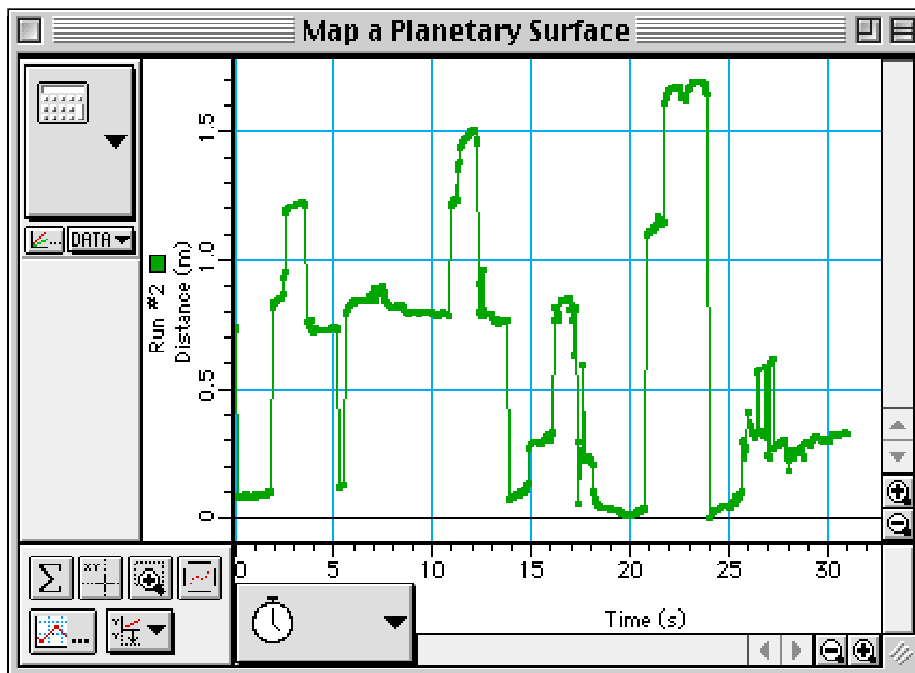
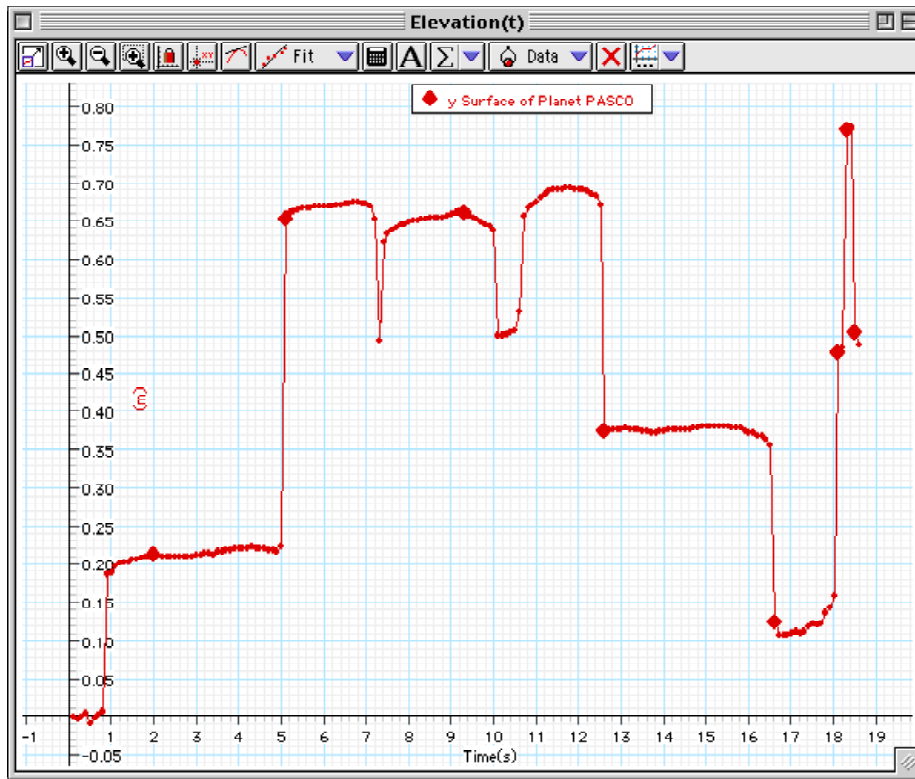



Memorandum – Activity M05: Acceleration of a Falling Object

To: Space Research Team
From: Joe Venus, Space Agency Administrator
Date: 05 Nov. 2017 AD

Greetings,

Congratulations on the great effort to test the planetary mapping procedure.

A problem has surfaced. The Space Agency needs your help in solving it. I know we can count on your team to do a superb job.

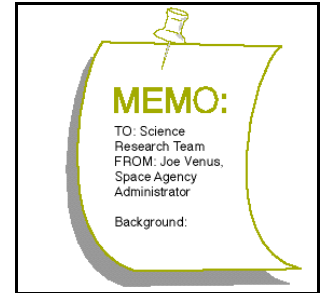

The landing system for the prototype spacecraft failed its first test. Similar to the Mars Pathfinder Lander, our spacecraft is designed to drop from its descent module and then bounce on the surface several times after initial impact.

The design engineers who tested the prototype spacecraft discovered hairline fractures in the fuselage after the test. They determined that the fractures are due to the stress of impact on landing.

We need you to determine the acceleration of the spacecraft as it is falling, and the acceleration of the spacecraft due to the landing and bouncing.

While the spacecraft is descending through the vacuum of space, the only force acting on it is the force of gravity. For a spacecraft near a planet, the acceleration is virtually a constant value.

When the spacecraft hits the planet, it undergoes a very large, very fast change in its velocity. This usually means that the acceleration is many times greater than the acceleration during the descent. However, this large acceleration lasts for a very short time. We need you to measure the acceleration.

The next section of this Workbook is the *Procedure Outline* for this activity. It will give you some ideas, but, as always, if you can improve on the methods or materials, please do so. Remember, read and heed the *Safety Reminders* in the outline.

Refer to the *Technical Manual* in *Appendix B* of this Workbook for more detailed information on this task.

Please submit your reports to the project manager so the manager can forward them to me. I know you will put in your best work on this important task.

Good luck.

Yours,

Joe Venus
Space Agency Administrator

Procedure Outline – Activity M05: Acceleration of a Falling Object

This is a **LAB** activity.



Equipment Needed	Qty	Equipment Needed	Qty
Motion Sensor (CI-6529)	1	Meter stick	1
Ball (hard rubber)	1	Level (optional)	1
Base & Support Rod (ME-9355)	1		

VOCABULARY	free fall	gravity
-------------------	-----------	---------

What Do You Think?

What is the acceleration of a falling object near the surface of a planet? What is the acceleration of the object when it bounces on the surface?



Take time to answer the 'What Do You Think?' question(s) in the Lab Report section.

Background

When the Mars Pathfinder Lander spacecraft landed on Mars, it dropped from its descent module and bounced several times after hitting the surface. Over twenty-two centuries ago, a Greek philosopher and scientist named Aristotle proposed that there is a natural force that causes heavy objects to fall toward the center of a planet such as earth. He called this force **gravity**. In the seventeenth century, the English scientist Isaac Newton was able to show that gravity is a universal force that extends beyond earth. It is the force that causes the moon to orbit the earth and the earth and other planets to orbit the Sun.

When an object is in **free fall**, it means that the only force acting on it is the force of gravity. As an object falls freely, it accelerates. This means that its velocity changes. For a falling object near the surface of a planet, the rate of change of velocity is a constant value known as the "acceleration due to gravity".

When the object hits a surface, its velocity changes dramatically! The acceleration is usually much greater than the acceleration due to gravity.

Use a Motion Sensor to measure the motion of a falling ball before, during, and after it hits a surface and bounces. You can plot the motion of the ball to find the value of the acceleration due to gravity, and the value of the acceleration during each bounce.

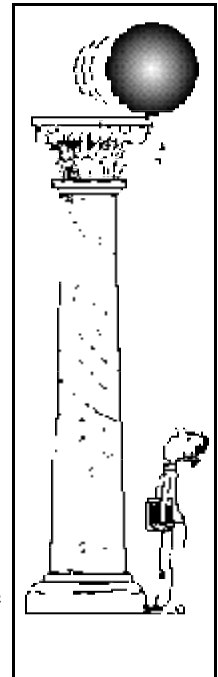

NOTE: See the Procedure Outline in *Activity M04 - Map a Planetary Surface* for information about the Motion Sensor.

The program uses a default value for the speed of sound (about 344 meters per second) to compute the distance to the object as follows:

$$\text{distance to object} = \frac{\text{roundtrip time}}{2} \times \text{speed of sound}$$

The speed of sound through air depends on several factors, including the temperature of the air. Because the temperature of air can change, the speed of sound can change. You will calibrate the Motion Sensor so the program can accurately compute the distance to an object.

SAFETY REMINDERS: Follow directions for using the equipment.

Procedure Outline

[✓] Remember, for more detailed information see *Appendix B*.

In this activity, calibrate the Motion Sensor and then use the sensor to measure the motion of a falling ball. The *ScienceWorkshop* program records and displays the position and velocity of the ball as it falls, hits a surface, and bounces.



[] **A. Set Up the Equipment**

1. Mount the Motion Sensor on the support rod. Place the sensor near the edge of a table, and turn the sensor so it is aimed at the floor.
 - Make sure that the floor is level. If it is not, put a hard flat surface on the floor and put pieces of paper or shims under the edges of the hard flat surface to level it.
2. Adjust the Motion Sensor so it is exactly 1 meter above the floor or flat, hard surface.
 - Remove the meter stick after you've used it to measure the distance from the sensor to the floor.

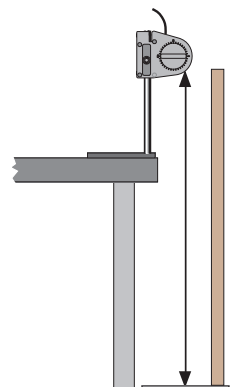

[] **B. Set Up the Equipment**

1. Connect the sensor to the interface.
2. Start *DataStudio* or *ScienceWorkshop* and open the file as follows:

DataStudio	ScienceWorkshop (Mac)	ScienceWorkshop (Win)
M05 Falling Object.DS	M05 Free Fall & Bounce	M05_BOUN.SWS

[] **Pre-Lab: Calibrate the Motion Sensor**

1. Calibrate the Motion Sensor *before* you use it to measure the motion of the falling ball.

NOTE: See *Appendix B* for more information about how to calibrate the sensor.

[] **C. Do the Experiment**

1. Adjust the position of the Motion Sensor on the support rod so that there is 1.5 meters between the Motion Sensor and the floor.
2. Hold the ball between your finger and thumb under the Motion Sensor *no closer than 15 cm* (about 6 inches) below the Motion Sensor.
3. Begin data recording and then drop the ball. Let the ball bounce several times.
 - NOTE: Be sure to move your hand out of the way as soon as you release the ball.
4. After the ball has bounced several times on the floor, stop the data recording.

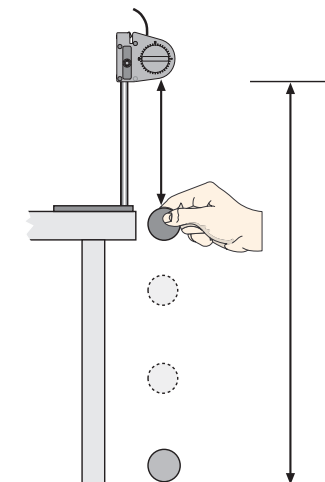

[] **D. Analyze the Data**

1. Use the Graph display to determine the acceleration of the ball *as it falls* and also each to find the maximum acceleration *each time the ball bounces*.
2. Record your data and answer the questions in the Report.

Report – Activity M05: Acceleration of a Falling Object

Report –
 PURPOSE: _____
 DATA: _____
 CONCLUSIONS: _____
 QUESTIONS: _____
 VOCABULARY: _____

NAME _____

CLASS _____

DATE _____

[] What Do You Think?

What is the acceleration of a falling object near the surface of a planet? What is the acceleration of the object when it bounces on the surface?

Answers will vary. Students may predict that the acceleration of a falling object near the surface of a planet depends on the strength of that planet's gravitational field. Students may predict that the acceleration during a bounce will be much greater than the acceleration during free fall.

[] Analyze the Data

- The Graph display shows the position and the acceleration of the ball as it falls, and then as it bounces.
- 1. Use the 'Smart Tool' in *DataStudio* or the 'Smart Cursor' in *ScienceWorkshop* to determine the acceleration of the ball as it falls.
- 2. Use the Graph display to determine the acceleration of the ball each time that it bounces.

Item	Falling	Bounce #1	Bounce #2	Bounce #3	Bounce #4
Acceleration	~ 10 m/s ²	~ -60 m/s ²	~ -55 m/s ²	~ -47 m/s ²	n.a.

- 3. Sketch the plot of position and the plot of acceleration for the ball as it falls and bounces.
- *The plot of position versus time shows a mirror image of the ball's motion.*
- *The plot of acceleration shows that the ball has a constant acceleration while it is falling and between the bounces. The ball has a sharp reverse in direction (acceleration is negative) as well as a sharp change of speed at each bounce.*
- *The acceleration during the first bounce is about six times greater than the acceleration during the fall or the acceleration between bounces.*
- *The acceleration during each bounce decreases.*

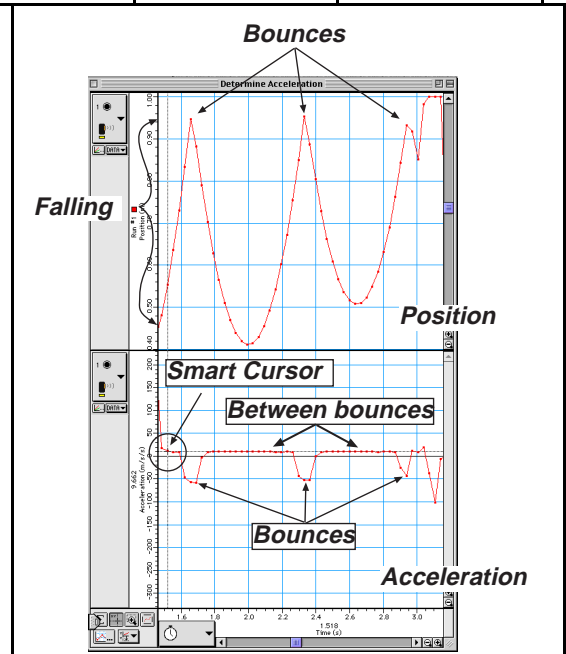

[] Conclusiong

Answers will vary. One conclusion is that the acceleration of the object is constant during the fall and between the bounces, but the acceleration is much greater during the bounces.

[] Questions

1. How do your answers to the 'What Do You Think?' questions compare to the results?

Answers will vary. _____

2. Approximately how many times greater is the acceleration during the first bounce than the acceleration during the fall?

The acceleration during the first bounce is approximately six times greater than the acceleration during the fall (or between the bounces).

3. What happens to the amount of acceleration during each bounce?

The amount of acceleration decreases from the first bounce to the next.

Complete the following:

VOCABULARY

free fall: Free fall happens when an object is falling, and the only force acting on it is gravity (as when it falls in a vacuum, for example).

gravity: Gravity is the force of attraction between objects.

Submit this report to your project manager as soon as possible so it can be forwarded to the Space Agency administrator.

Teacher's Notes – Activity M05: Acceleration of a Falling Object

Time Estimates	Preparation: 15 min	Activity: 30 min
-----------------------	----------------------------	-------------------------

Objectives

Students will be able to...

- use a Motion Sensor to measure the motion of an object as it falls and then bounces
- determine the amount of acceleration of the object as it is falling
- determine the amount of acceleration of the object as it bounces

Notes

Preparation

Calibrating the Motion Sensor is quick and easy. You may want to show the procedure before you ask your students to do it.

- This setup prepares the Motion Sensor for calibration.
1. Mount the Motion Sensor on the support rod. Place the sensor near the edge of a table, and turn the sensor so it is aimed at the floor.
 - Make sure that the floor is level. If it is not, put a hard flat surface on the floor and put pieces of paper or shims under the edges of the hard flat surface to level it.
 2. Adjust the Motion Sensor so it is exactly 1 meter above the floor or flat, hard surface. Remove the meter stick after you've used it to measure the distance from the sensor to the floor.
 3. Start *DataStudio* or *ScienceWorkshop* and open the file as follows:

DataStudio	ScienceWorkshop (Mac)	ScienceWorkshop (Win)
M05 Falling Object.DS	M05 Free Fall & Bounce	M05_BOUN.SWS

Calibration

4. In the Experiment Setup window, double-click the sensor's icon.
- **Result:** In *DataStudio*, the Sensor Properties window opens.
Click the 'Motion Sensor' tab. **Result:** The calibration window opens and the sensor begins to click a few times per second.
- **Result:** In *ScienceWorkshop*, the sensor's calibration window opens and the sensor begins to click a few times per second.

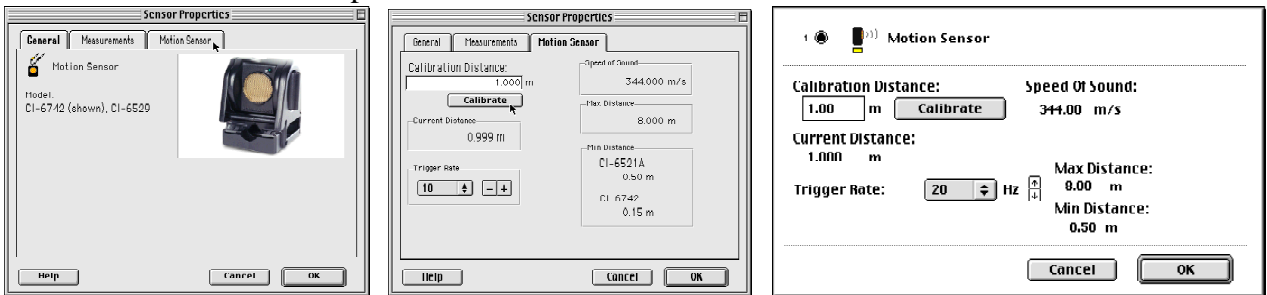

5. Calibrate the software.
 - **First**, make sure that the sensor is one meter from the target.
 - **Second**, click the 'Calibrate' button in the Motion Sensor window. **Result:** The software calculates the speed of sound based on the calibration distance (one meter) and the round trip time of the pulse and echo
6. Click 'OK' to return to the Experiment Setup window.

Data Recording

Remind the student who drops the ball to pull his or her hand back out of the way once the ball is released.

Data Analysis

This activity uses the built-in analysis tools of the Graph display. If students have not had much experience with this feature, you may want to preview it for them. Use the 'Smart Tool' (in *DataStudio*) or the 'Smart Cursor' (in *ScienceWorkshop*) to display the y- and x-coordinates of any point in the display area of the Graph. In *DataStudio*, the y- and x- coordinates appear next to the pint. In *ScienceWorkshop*, the y-coordinate of the cursor's position appears along the vertical axis, and the x-coordinate of the cursor's position appears below the horizontal axis.

The plot of position versus time for the falling and bouncing ball is a "mirror image" of the actual motion of the ball.

Extensions

Try dropping larger objects to see whether their acceleration during 'free fall' is the same as for the small rubber ball.

Try dropping a cone shaped paper filter such as the kind used in drip coffee machines. Drop the filter with the flat or cone shape end facing the floor.

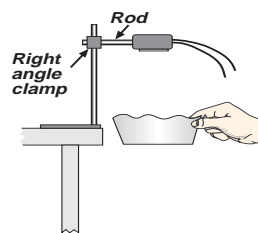

Sample Data

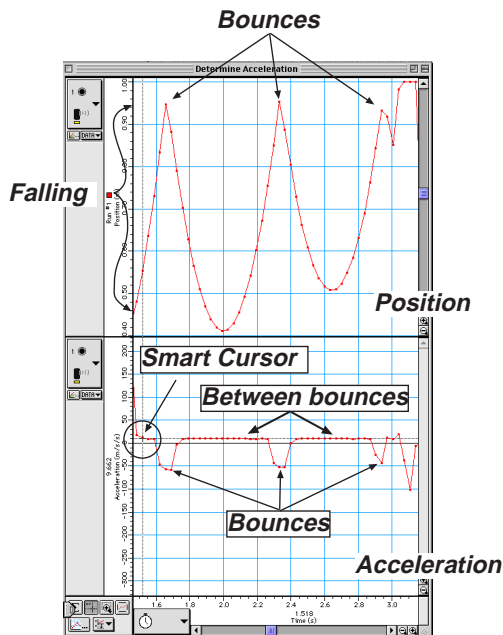
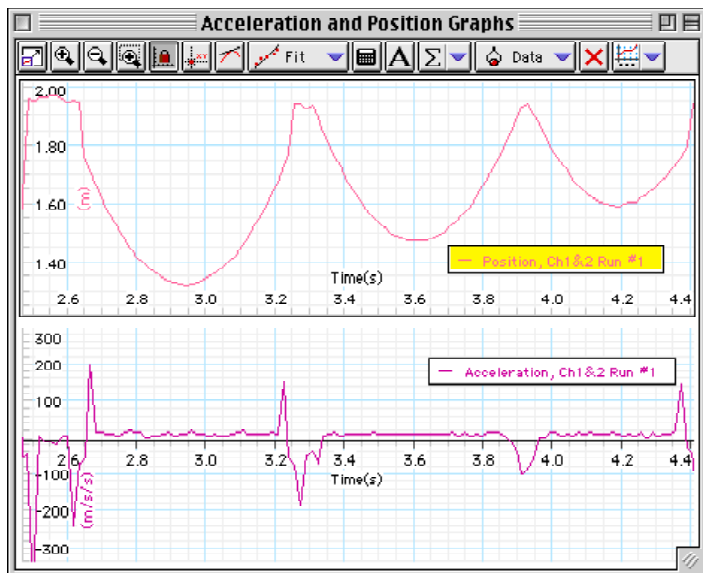



Memorandum – Activity M06: Design Landing Bags

To: Space Research Team
From: Joe Venus, Space Agency Administrator
Date: 09 Nov. 2017 AD

Greetings,

Thanks to your work on measuring the acceleration during free fall, the Mission to Other Worlds project is back on schedule. Good job. The design engineers have made progress in changing the prototype spacecraft.

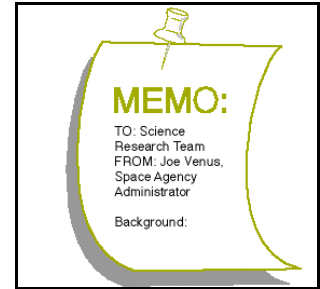

The re-designed landing system for the spacecraft is similar to the landing bag system for the Mars Pathfinder. After a free fall through the atmosphere, the descent module and its contents will be cushioned at impact by an array of gas bags that surround the vehicle.

To avoid damage to the descent module, the gas bags surrounding it must not compress to the point where the body of the landing craft hits the surface. There must always be a cushion of air between the craft and the planet's surface, even at the point of highest impact.

The engineers designing the gas bags would like you to investigate the relationship between the pressure and volume of gases so they can design the gas bag array safely. You need to do a little research into Boyle's Law.

Basically, Boyle's Law is a description of what happens to the pressure of a gas when its volume is changed and *vice versa*.

We need you to carefully measure the change in pressure in a chamber filled with air as the volume of the air is physically altered. We hope that you can graph your data and determine the relationship between the volume and pressure.

The next section of this Workbook is the *Procedure Outline* for this activity. It will give you some ideas, but, as always, if you can improve on the methods or materials, please do so. Remember, read and heed the *Safety Reminders* in the outline.

Refer to the *Technical Manual* in *Appendix B* of this Workbook for more detailed information on this task.

Please submit your reports to the project manager so the manager can forward them to me.

Yours,

Joe Venus
Space Agency Administrator

Procedure Outline – Activity M06: Design Landing Bags

This is a **LAB** activity.



Equipment Needed	Qty	Equipment Needed	Qty
Pressure Sensor - Absolute (CI-6532)	1	Syringe (included with sensor)	1
Plastic tubing (included with sensor)	2.5 cm	Consumables	Qty
Quick-release connector (included)	1	Glycerin	1 mL

VOCABULARY	pressure	tetrahedron	volume
-------------------	----------	-------------	--------

What Do You Think?

What is the relationship between the pressure of a gas and the volume of the gas when the volume of the gas is changed by an outside force?



Take time to answer the 'What Do You Think?' question(s) in the Lab Report section.

Background

When the Mars Pathfinder spacecraft landed on Mars on July 4, 1997, the tetrahedron shaped lander was protected during impact by circular gas bags mounted on the four exterior surfaces. These gas bags were inflated just moments before the spacecraft hit the surface of Mars.

Robert Boyle was an English scientist who lived at the same time as Isaac Newton. Boyle discovered that when a gas is inside a container such as a cylinder and a piston moves up or down in the cylinder to change the volume of the gas, something also happens to the pressure of the gas.

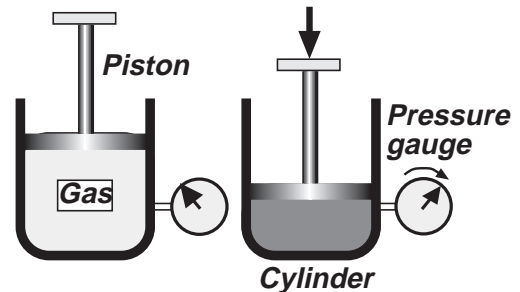

If the volume increases, the pressure decreases. If the volume decreases, the pressure increases. Boyle's Law states that for a given amount of a gas at a *fixed temperature* the pressure of the gas is inversely proportional to the volume.

SAFETY REMINDERS: Follow directions for using the equipment.

Procedure Outline

[✓] Remember, for more detailed information see *Appendix B*.

In this activity, use the Pressure Sensor to measure the change in pressure inside a syringe as the piston is pushed into the syringe. As the volume changes, you will type in the amount of volume at each point as the piston is pushed farther into the syringe. The program records and displays the pressure and volume data. Use the Graph display to figure out the relationship of pressure and volume.



[] A. Set Up the Equipment

- Put a drop of glycerin on the barb end of a quick release coupling. Put the end of the coupling into one end of a short piece (about 2.5 cm) of plastic tubing that comes with the Pressure Sensor.
- Put a drop of glycerin on the end of the syringe. Connect the end of the syringe to the other end of the small piece of plastic tubing.
- Align the quick-release coupling on one end of the plastic tubing with the pressure port of the Pressure Sensor. Push the coupling onto the port, and then turn the coupling clockwise until it clicks (about one-eighth turn).
- Check that the syringe and Pressure Sensor have a secure seal by adjusting the volume between 20 mL and 10 mL. It should get harder to push as the volume decreases.
- Adjust the volume of air in the syringe to 20.0 mL. (Note: To set the initial position of the piston in the syringe, disconnect the quick-release connector from the sensor, move the piston to the first position (20 mL), and then re-connect the quick-release connector to the sensor.)

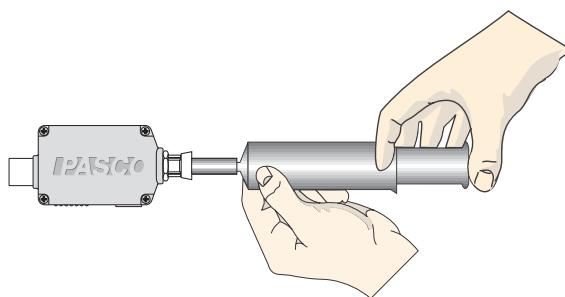
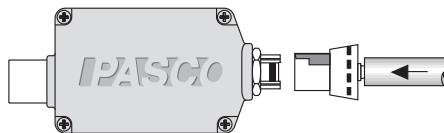
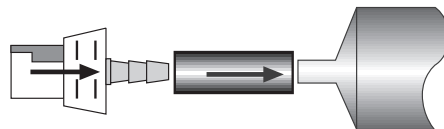



[] B. Set Up the Experiment

- Connect the sensor to the interface. Start *DataStudio* or *ScienceWorkshop* and open the file as follows:

DataStudio	ScienceWorkshop (Mac)	ScienceWorkshop (Win)
M06 Landing Bags.DS	M06 Airbags	M06_BAG.SWS

- The file opens with a Graph display, a Table display, and a Digits display. The Graph and Table displays show the pressure and volume. The Digits display shows pressure. The data recording rate is set to one measurement per second.
- You can use the keyboard to type in the amount of volume as you change it.

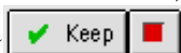
[] C. Do the Experiment — Data Recording (for *DataStudio*)

- In *DataStudio*, the Table display shows values for the gas volume in the syringe (for example, 20, 18, 16 and so on).
1. When everything is ready, start recording data. (Hint: In *DataStudio*, click 'Start').
 - In *DataStudio*, the 'Start' button changes to 'Keep' () and the Table display shows the value of pressure next to the first volume (20 mL).
 2. Click 'Keep' to record the pressure.
 - The Table display changes to show the next value of volume (18 mL).
 3. Move the piston to the 18 mL mark and click 'Keep' to record the pressure.
 4. Continue to move the piston to each new position and then click 'Keep' to record the corresponding pressure.
 5. After you record the pressure for the last volume, click 'Stop' () to end data recording.
 6. If time permits, repeat the procedure.

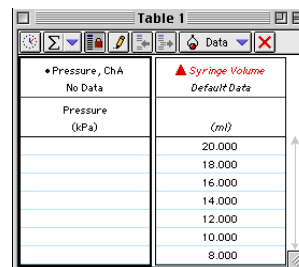

Pressure, ChA	Syringe Volume
No Data	Default Data
Pressure (kPa)	(mL)
	20.000
	18.000
	16.000
	14.000
	12.000
	10.000
	8.000

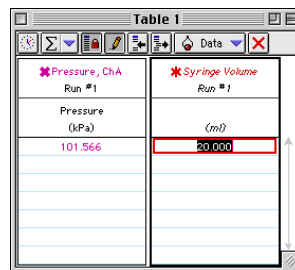

Pressure, ChA	Syringe Volume
Run #1	Run #1
Pressure (kPa)	(mL)
101.566	20.000

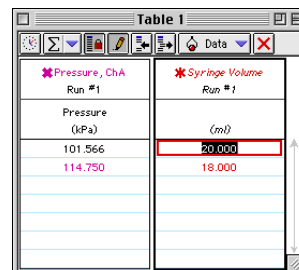

Pressure, ChA	Syringe Volume
Run #1	Run #1
Pressure (kPa)	(mL)
101.566	20.000
114.750	18.000

[] C. Do the Experiment — Data Recording (for *ScienceWorkshop*)

1. In *ScienceWorkshop*, click 'REC' to start recording data.
- The Keyboard Sampling window opens.
2. When the pressure reading stabilizes, type "20" for the volume of air in the syringe and click 'Enter' to record the pressure.
3. Reduce the volume to 18 mL. Type 18 for the volume and click 'Enter'. (Note: *ScienceWorkshop* will prompt you for the third volume based on the pattern of the first two volumes.)
4. Continue reducing the volume by 2.0 mL each time, checking the pressure, and entering the new volume until your last entered volume is 10.0 mL.
5. After you enter the last volume, click 'Stop Sampling' to end data recording. The 'Keyboard Sampling' window will close automatically.
6. If time permits, repeat the procedure.

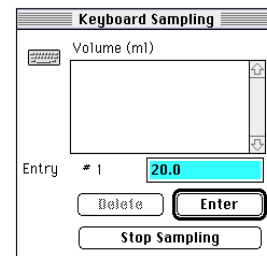

Keyboard Sampling

Volume (mL)

Entry # 1: 20.0

Buttons: Delete, Enter, Stop Sampling

[] D. Analyze the Data

1. Set up the Graph display so you can examine the plot of Volume versus Pressure and also the plot of Inverse Volume versus Pressure.
2. Determine the relationship of the pressure and volume of the air.
3. Record your results and answers the questions in the Report.

Report – Activity M06: Design Landing Bags

Report –
PURPOSE:
DATA:
CONCLUSIONS:
QUESTIONS:
VOCABULARY:

NAME _____

CLASS _____

DATE _____

[] What Do You Think?

What is the relationship between the pressure of a gas and the volume of the gas when the volume of the gas is changed by an outside force?

Answers will vary. Students may predict that the volume of the gas will decrease when the force on the outside is increased.

[] Analyze the Data

- The first plot on the Graph display shows the pressure and the volume of the air inside the syringe. The second plot on the Graph display shows the pressure of the air versus the inverse of the volume ($1/\text{Volume}$).
1. Examine the Graph display to determine the relationship of the pressure and the volume of the air in the syringe.
 2. Sketch the plot of Volume and the plot of $1/\text{Volume}$ for the air in the syringe.
- *The plot of volume versus pressure shows that the volume decreases as the pressure increases. This means that volume and pressure are inversely proportional.*
 - *The plot of $1/\text{volume}$ versus pressure shows a straight line. This supports the conclusion that volume and pressure are inversely proportional. The plot shows that $1/\text{volume}$ and pressure are directly proportional.*

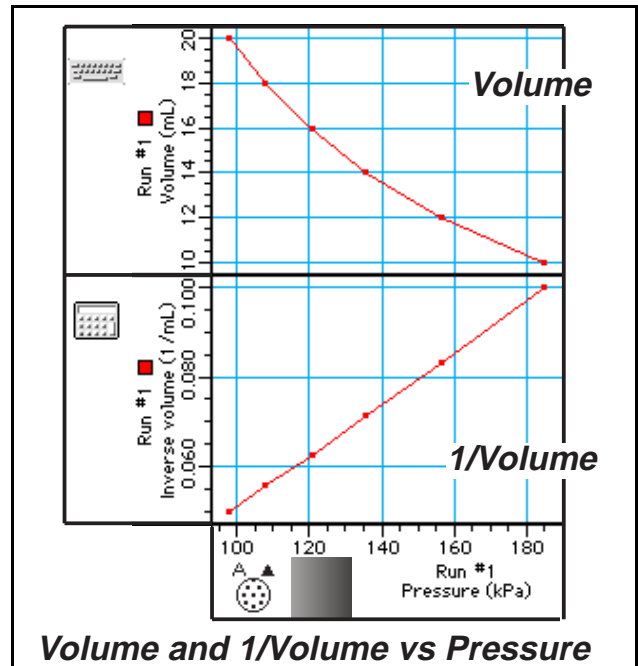

[] Conclusion

Answers will vary. One conclusion is that the relationship of pressure and volume is an inverse relationship. The volume goes down as the pressure goes up..

[] Questions

1. How does your answer to the 'What Do You Think?' question compare to the results?

Answers will vary. _____

2. What happened to the pressure in the syringe as you decreased the volume of the air by pushing in the piston?

The pressure in the syringe increased as the volume in the syringe decreased due to pushing the piston.

3. How does the shape of the plot of Volume compare to the shape of the plot of 1/Volume?

The shape of the plot of volume is a curve whereas the shape of the plot of 1/volume is a straight line.

Complete the following:

VOCABULARY

pressure: Pressure is the ratio of the force applied to a surface, divided by the area of the surface.

tetrahedron: A tetrahedron is a geometric shape with four sides, each side being an equilateral triangle.

volume: Volume is a measure of the amount of space taken by an object. The volume of a box, for example, is the product of its height, width, and depth.

Submit this report to your project manager as soon as possible so it can be forwarded to the Space Agency administrator.

Teacher's Notes – Activity M06: Design Landing Bags

Time Estimates	Preparation: 15 min	Activity: 15 min
-----------------------	----------------------------	-------------------------

Objectives

Students will be able to...

- use a Pressure Sensor to measure the change in pressure of a gas inside a cylinder as the volume of the gas is changed as a piston moves into the cylinder
- describe the relationship between the volume of a gas and the pressure of a gas
- determine whether the relationship between the volume and pressure of a gas is direct or not

Notes

Preparation

In this activity, the student can use the keyboard to type in the amount of volume as they change the pressure on the gas in the syringe. You may want to show the procedure before you ask your students to do it.

Be sure that the syringe is originally set to a volume of 20.0 mL when it is connected to the Pressure Sensor.

The primary source of error is the volume of air unaccounted for in the tubing and pressure chamber of the sensor. By creating a new quantity called total volume, a reasonable 0.5 mL can be added to the volume of air in the syringe as a correction factor. Students could adjust this value to get the best results and then compare that with the volume of air they calculate to be inside the tubing connecting the sensor to the syringe.

Safety

Connecting the sensor to the syringe requires a short piece of plastic tubing. Because the tubing can be difficult to cut, consider cutting short pieces before the beginning of the activity. Also warn the students not to compress the air to a volume of less than 8 or 10 mL. The pressure can become too great, causing errors due to the added stress on the tubing. Excessive pressure may cause the syringe to detach from the plastic tubing.

Setup

Connecting the sensor to the syringe takes only a few minutes.

Data Recording

Remind the students to be careful during data collection. It is important that the piston is at the *exact* position in the syringe (i.e., 20 mL, 18 mL, 16 mL, etc.) when they click 'Keep' or 'Enter'.

Data Analysis

In this activity, the simplest analysis is the best. Students should see that the pressure goes *up* as the piston is pushed into the syringe to make the volume go *down* ("compress the gas").

Extensions

Disconnect the end of the plastic tubing from the sensor. Put the piston at the 10 mL mark. Reconnect the tubing to the sensor. Repeat the data recording procedure, but move the piston outward (from 10 mL to 12 mL to 14 mL, etc.). In other words, *increase* the volume of the gas inside the syringe and see what happens to the pressure.

DataStudio Sample Data

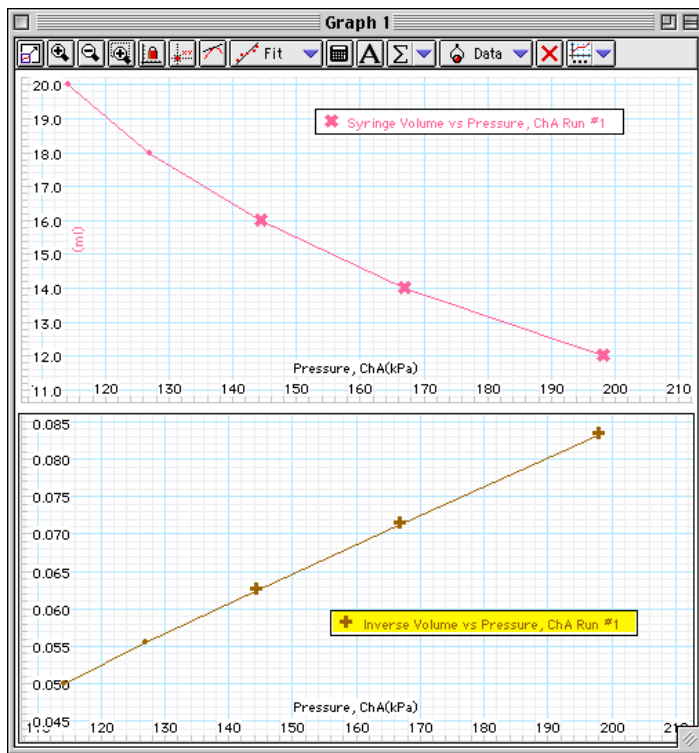

Pressure, ChA Run #1	Syringe Volume Run #1	Inverse Volume Run #1
Pressure (kPa)	(ml)	Y
114.261	20.000	0.050
126.957	18.000	0.056
144.536	16.000	0.062
166.997	14.000	0.071
198.248	12.000	0.083

ScienceWorkshop Sample Data

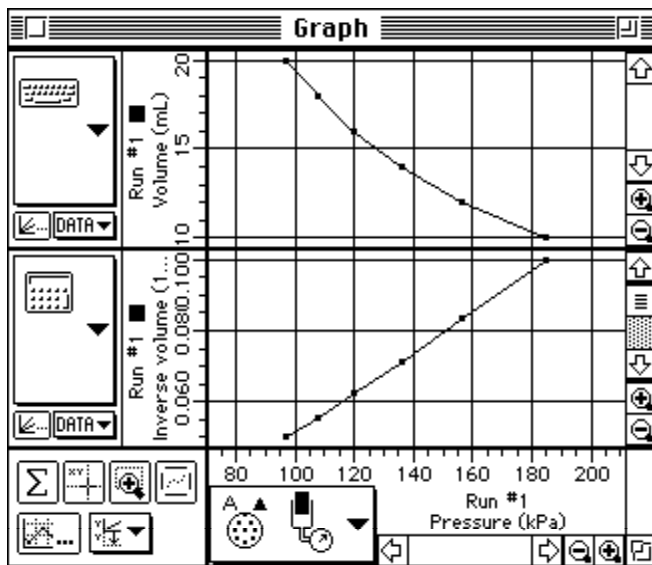

Index	Run #1 Pressure (kPa)	Run #1 Volume (mL)	Run #1 Invol (1/mL)
1	97.110	20.000	0.050
2	107.852	18.000	0.056
3	120.060	16.000	0.063
4	136.174	14.000	0.071
5	156.682	12.000	0.083
6	184.515	10.000	0.100



Memorandum – Activity M07: Temperature at Different Locations

To: Space Research Team
From: Joe Venus, Space Agency Administrator
Date: 20 Nov. 2017 AD

Greetings,

Good work on the task of determining the relationship between pressure and volume of a gas as the volume is altered. I read the reports that your project manager forwarded to me.

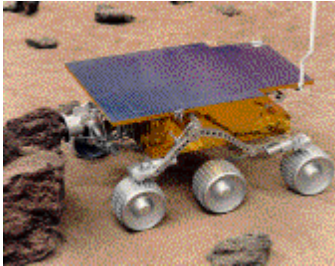
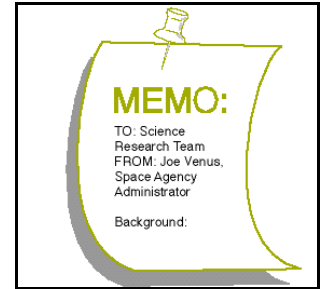

The next phase of your Mission to Other Worlds project focuses on ways to explore the alien planet's surface.

As you know, the Mars Pathfinder Lander safely delivered the Sojourner Rover onto the surface of Mars in 1997. The Sojourner was able to travel across the Martian terrain and make dozens of measurements on the surface. It used a special X-ray spectrometer to determine the composition of many of the rocks near the landing site.

We are planning to include several instruments on the new robot rover that will be part of the payload. One of the instruments will measure the temperature at each location that the rover visits. The rover will be able to extend a robot arm and put the temperature sensor in direct contact with the planet's surface.

We also plan to measure the temperature in direct sunlight and compare it to the temperature on the shady side of rocks on the surface. If the rover encounters any liquid water on the surface it will measure the temperature there as well.

We need you to test our Temperature Sensor. Carefully measure the temperature at a variety of locations (including in sunlight and in shade). Use the "data logging" feature of your computer interface. We especially want you to test the Temperature Sensor in both wet and dry conditions.

The next section of this Workbook is the *Procedure Outline* for this activity. It will give you some ideas, but, as always, if you can improve on the methods or materials, please do so. Remember, read and heed the *Safety Reminders* in the outline.

Refer to the *Technical Manual* in *Appendix B* of this Workbook for more detailed information on this task.

Please submit your reports to the project manager so the manager can forward them to me.

Yours,

Joe Venus
Space Agency Administrator

Procedure Outline – Activity M07: Temperature at Different Locations

This is a **FIELD** activity.



Equipment Needed	Qty	Other	Qty
<i>ScienceWorkshop</i> TM 500 Interface	1	<i>remote control model vehicle (option)</i>	1
Temperature Sensor (CI-6505A)	1		

VOCABULARY | exobiologist

What Do You Think?

How much difference in temperature is there between direct sunlight and dark shade? How much difference in temperature is there between a dry surface and a wet surface?



Take time to answer the 'What Do You Think?' question(s) in the Lab Report section.

BACKGROUND

Both the Mars Pathfinder spacecraft that landed on Mars in July, 1997, and the Viking Lander spacecraft that landed on Mars in July, 1976, used instruments to measure the temperature of the Martian atmosphere.

The Viking Lander also made measurements of the change in temperature near the surface of Mars during the seasons on that planet, as well as the change in temperature between day and night.

When these measurements were received as radio signals on earth, they helped planetary scientists and exobiologists learn more about the climate on Mars. One discovery they made is that it is frequently cold enough on Mars that carbon dioxide gas in the atmosphere can freeze to become dry ice.

They also discovered that the thin air on Mars does not contain very much thermal energy.

Atmospheric temperatures from Pathfinder Atmospheric Structure Instrument

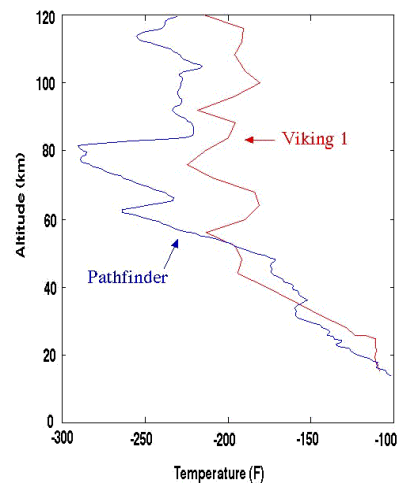

SAFETY REMINDERS: Follow directions for using the equipment.

PROCEDURE OUTLINE

[✓] Remember, for more detailed information see **Appendix B**.

In this activity, use a Temperature Sensor and the *ScienceWorkshop* 500 Interface to measure the temperature at several different locations. The *ScienceWorkshop* program records the temperature data. You can use the Table display to find the minimum, maximum, and mean values of the temperature at different locations.



[] **A. Set Up the Equipment**

1. Connect the sensor's DIN plug into Analog Channel A on the interface.

[] B. Set Up the Experiment

You can use the *ScienceWorkshop 500* Interface to record data outside a classroom. You can program the interface while it is connected to the computer, disconnect the interface and go collect data, and then re-connect the interface to the computer to analyze your data.

See Appendix C about using the *ScienceWorkshop 500* Interface for “data logging”

1. Start *DataStudio* or *ScienceWorkshop* and open the file as follows:

DataStudio	ScienceWorkshop (Mac)	ScienceWorkshop (Win)
M07 Location Temp.DS	M07 Remote Temperature	M07_REMO.SWS

- The file opens with a Table display of temperature. The data recording rate is set to two measurements per second.
2. Prepare the interface to be disconnected for data logging.
 3. Disconnect the interface from the computer and power supply.
 4. Carry the interface and Temperature Sensor to the first location.

[] C. Do the Experiment

1. Place the Temperature Sensor so its tip is against a surface that is exposed to direct sunlight. When you are ready to begin the experiment, press the LOG button on the interface to wake the interface.
 - The light-emitting diode (LED) blinks one per second for ten seconds. The interface is recording when the LED blinks rapidly.
2. Leave the Temperature Sensor in the contact with the surface that is in the sunlight for about sixty seconds. Press the LOG button again to stop recording data.
3. Hold the Temperature Sensor in the air so the entire sensor is exposed to the sunlight but the tip is not touching anything. Repeat the data recording procedure for about sixty seconds.
4. Place the Temperature Sensor so its tip is against a surface that is in a dark shadow. Repeat the data recording procedure for about sixty seconds.
5. Hold the Temperature Sensor in the air so the entire sensor is in the dark shadow. Repeat the data recording procedure for about sixty seconds.

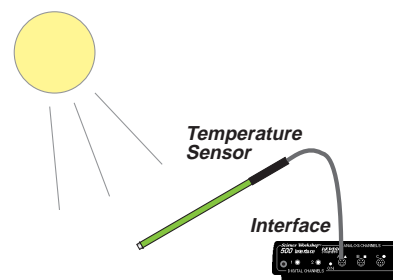

Optional

If there is a shallow puddle of water near some bare ground, measure the temperature of the water and then measure the temperature of the bare ground next to the water.

[] D. Analyze the Data

1. Reconnect the interface to the power supply and computer. Download the data from the interface to the computer. (See Appendix C.)
2. Examine each run of data in the Table display to determine the minimum, maximum, and mean value of temperature for each location and condition.
3. Record your results and answer the questions in the Report.

Report – Activity M07: Temperature at Different Locations



NAME _____

CLASS _____

DATE _____

[] What Do You Think?

How much difference in temperature is there between direct sunlight and dark shade? How much difference in temperature is there between a dry surface and a wet surface?

Answers will vary. There probably will be a measurable difference in temperature between direct sunlight and dark shade. They may not be much difference between a dry surface and a wet surface.

[] Analyze the Data

1. Examine each run of data in the Table display to determine the minimum, maximum, and mean values of temperature for each location and condition.

Data Table

Location/condition	Minimum Temp (°C)	Maximum Temp (°C)	Mean Temp (°C)
surface/direct sun			
air/direct sun			
surface/dark shade			
air/dark shade			
water at 1 cm depth			
soil at 1 cm depth			

[] Conclusion

Answers will vary. One conclusion is that the temperature of a surface exposed to sunlight is greater than the temperature of air in sunlight.

[] Questions

1. How do your answers to the 'What Do You Think?' questions compare to the results?

Answers will vary. _____

2. Which pair of conditions had the greatest difference in temperature?

Answers will vary. _____

3. Which pair of conditions had the smallest difference in temperature?

Answers will vary. _____

Complete the following:

VOCABULARY

exobiologist: An exobiologist is a biologist concerned with life forming or existing outside the earth or its atmosphere

Submit this report to your project manager as soon as possible so it can be forwarded to the Space Agency administrator.

Teacher's Notes – Activity M07: Temperature at Difference Locations

Time Estimates	Preparation: 15 min	Activity: 30 min
-----------------------	----------------------------	-------------------------

Objectives

Students will be able to...

- use a Temperature Sensor and the *ScienceWorkshop* 500 Interface to measure the temperature at different locations and under different conditions
- determine the difference in temperature between direct sunlight and dark shape
- determine the difference in temperature between a dry surface and a wet surface

Notes

Preparation

One part of the preparation is to find places close to the classroom where your students can measure different temperatures (e.g., sunlight, dark shape, wet surface, dry surface).

Role-Playing

This “data logging” activity allows students to take on various roles.

For example, one student in a group can be the **Computer Officer** — responsible for setting up the experiment in *ScienceWorkshop* and for dis-connecting and re-connecting the interface and the computer.

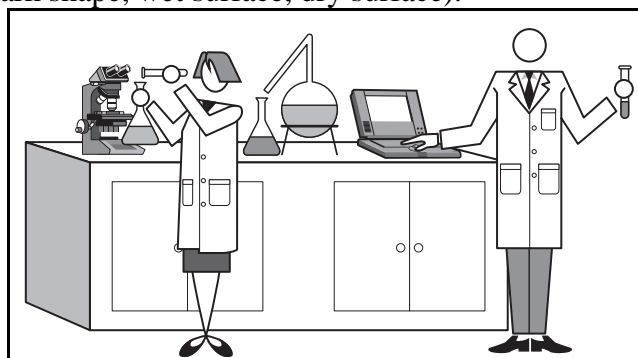

A second student can be the **Instrument Officer** — responsible for pressing the LOG button on the interface and holding the Temperature Sensor. A third student can be the **Records Officer** — responsible for keeping track of time and for recording the location and condition for each run of data.

Safety

Remind students to follow directions for using the equipment.

Setup

Connecting the sensor to the interface and preparing the interface for data logging takes only a few moments.

Data Recording

Remind the Records Officer to time the data recording so it lasts sixty seconds for each trial.

Extensions

One extension is to mount the interface and sensor on top of a remote control model vehicle. Start data recording, and then let a student “drive” the vehicle from location to location.

A second extension is to place the interface and temperature sensor inside a refrigerator. Record the difference in temperature as the refrigerator door is opened and closed

A third extension is to place the interface and temperature sensor inside an automobile whose windows and doors are closed.

Sample Data

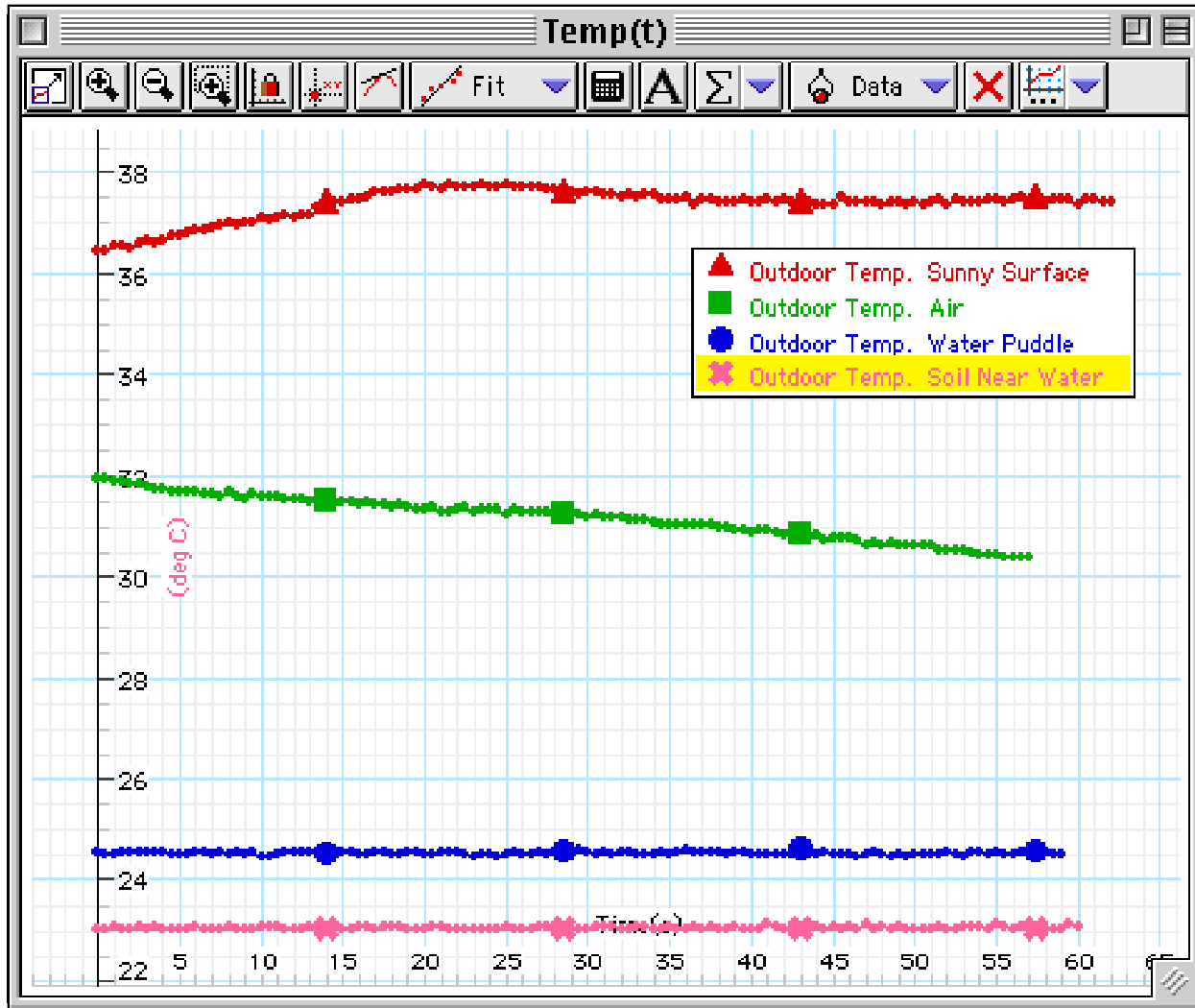



Memorandum — Activity M08: Relative Humidity

To: Space Research Team
From: Joe Venus, Space Agency Administrator
Date: 04 Dec. 2017 AD

Greetings,

Your reports on the temperatures at various different locations were excellent. The data you collected helps us to know what we can expect when we use an instrument like the Temperature Sensor on the Mission to Other Worlds.

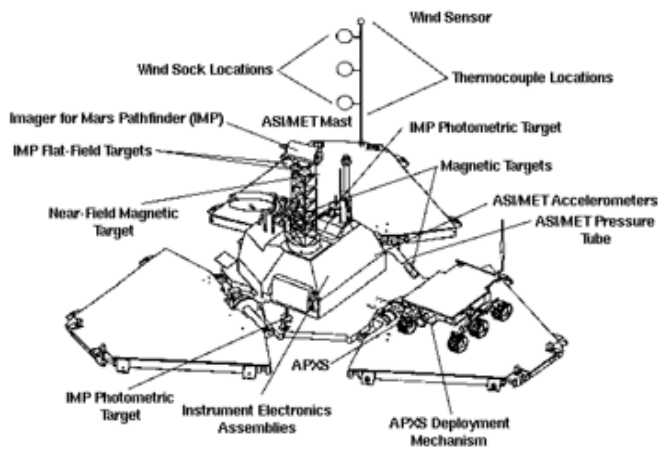
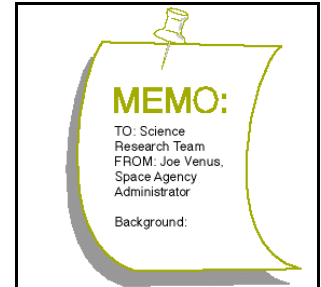

Your next task requires the kind of ingenuity and skill that your team has consistently demonstrated.

We are planning to include a new instrument on board the spacecraft that will (hopefully) measure relative humidity of the air (if any) on the planets we visit. Since measurement of relative humidity is so important to the understanding of the weather on another planet, we've decided to include a backup system for measuring relative humidity.

Unfortunately, adding a backup system always increases the weight of the payload that the spacecraft must carry.

Therefore, we want to be certain that we can get good results with the backup system, and that the system we use is as simple and lightweight as possible.

Your team is selected to test our backup measurement system for Relative Humidity. The system uses two Temperature Sensors, and your experience in measuring temperature at different locations will be very important for this task.

Carefully measure the relative humidity in as many different locations and under as many different weather conditions as possible. If necessary, use the "data logging" feature of your computer interface. We especially want you to measure the relative humidity on both a clear day and a on a day when the weather is threatening to be stormy. Be sure to record accurate observations of the overall weather conditions on the days when you make your measurements.

The next section of this Workbook is the *Procedure Outline* for this activity. It will give you some ideas, but, as always, if you can improve on the methods or materials, please do so. Remember, read and heed the *Safety Reminders* in the outline.

Refer to the *Technical Manual* in *Appendix B* of this Workbook for more detailed information on this task.

We're counting on you to do a good job. Please submit your reports to the project manager so the manager can forward them to me.

Yours,

Joe Venus
Space Agency Administrator

Procedure Outline – Activity M08: Relative Humidity

This is a **LAB** activity with an optional **FIELD** activity.



Equipment Needed	Qty	Other	Qty
Temperature Sensor (CI-6505A)	2	Cardboard fan, about 15 by 15 cm	1
Container, 100 mL	1	Cheesecloth*, about 5 by 5 cm	1
		Rubber band	2
		Water, room temperature	100 mL

(*light cotton material can be used in place of cheesecloth)

VOCABULARY	humidity	psychrometer	relative humidity	specific humidity
------------	----------	--------------	-------------------	-------------------

What Do You Think?

What is the relationship of humidity to relative humidity? How can relative humidity be determined by measuring temperature?



Take time to answer the 'What Do You Think?' question(s) in the Lab Report section.

Background

The amount of water vapor in the air is called **humidity**. As water molecules evaporate, the humidity of the air increases. Certain climate regions on earth (such as deserts and the Arctic and Antarctic regions) have very low humidity, while other climate regions (such as tropical rain forests) have moderate to high humidity.



In general, the amount of water vapor that a given volume of air can hold increases as the temperature increases. A higher temperature allows more water to evaporate into water vapor. As the temperature goes down, the amount of water vapor in the air goes down because the water vapor molecules can condense into liquid form again. Therefore, the humidity drops. When the air holds all the water vapor it can at a given temperature, the air is *saturated*.

Relative humidity is a common way to describe the amount of water vapor in the air. **Relative humidity** is a ratio that compares the mass of water vapor in the air to the mass of water vapor that the air can hold at its saturation point. Relative humidity is always written as a percentage.

Specific humidity is the *actual* amount of water vapor in the air measured in grams of water vapor to one kilogram of air.

One instrument used to measure relative humidity is the sling **psychrometer**.

The psychrometer has two identical thermometers. The bulb of one thermometer is covered with damp cloth while the bulb of the other thermometer is kept dry. The psychrometer is twirled around in the air so the air circulates freely around the bulbs of both thermometers.

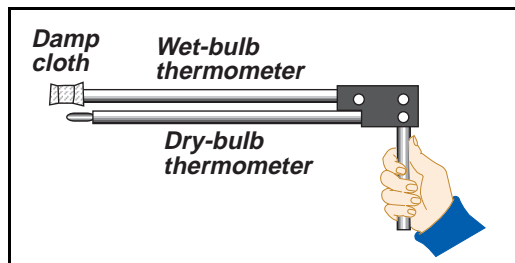

If the relative humidity is high, the water in the damp cloth on the wet-bulb thermometer doesn't evaporate very fast, and the temperature of the wet-bulb thermometer stays close to the temperature of the dry-bulb thermometer. However, if the relative humidity is low, there is less water vapor in the air. The water in the damp cloth evaporates more easily and the wet-bulb thermometer's temperature drops more rapidly.

Relative humidity is determined by comparing the dry-bulb temperature to the difference between the dry-bulb temperature and the wet-bulb temperature.

SAFETY REMINDERS

- Follow directions carefully when using the equipment for this activity.

THINK SAFETY
ACT SAFELY
BE SAFE!

Procedure Outline

Use two Temperature Sensors to measure the relative humidity during different weather conditions. Use *DataStudio* or *ScienceWorkshop* to record the temperature data. Use the Table display to find the values of the temperature for a dry-bulb Temperature Sensor and a wet-bulb Temperature Sensor.

[] A. Set Up the Equipment

1. Wrap the piece of cheesecloth or light cotton material around the end of one of the Temperature Sensors, and fasten the cloth in place with a rubber band. This will be the wet-bulb Temperature Sensor.
2. Put *room temperature* water into a container.

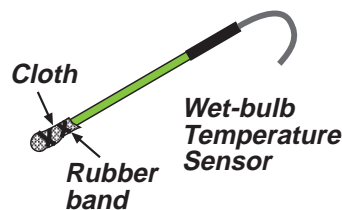

[] B. Set Up the Equipment

Computer Setup

1. Connect the dry-bulb Temperature Sensor's DIN plug into Analog Channel A on the interface. Connect the wet-bulb Temperature Sensor's DIN plug into Analog Channel B.
2. Start *DataStudio* or *ScienceWorkshop* and open the file titled as shown:

DataStudio	ScienceWorkshop (Mac)	ScienceWorkshop (Win)
M08 Humidity.ds	M08 Humidity	M08_HUMI.SWS

- The file has a Table Display, a Graph display, and a Digits display. Data recording is set at 5 measurements per second (5 Hz.)

[] C. DO THE EXPERIMENT

1. Write a description of the weather conditions (e.g., sunny, cloudy, foggy, etc.) and location (e.g., indoors, outdoors) in your report.

- Place both Temperature Sensors near the edge of a table so the ends of both sensors extend beyond the edge of the table.
- Moisten the cheesecloth with *room temperature* water.
- Begin data recording.
- Rapidly fan the ends of the sensors with the piece of cardboard.
- Stop data recording after 60 seconds.

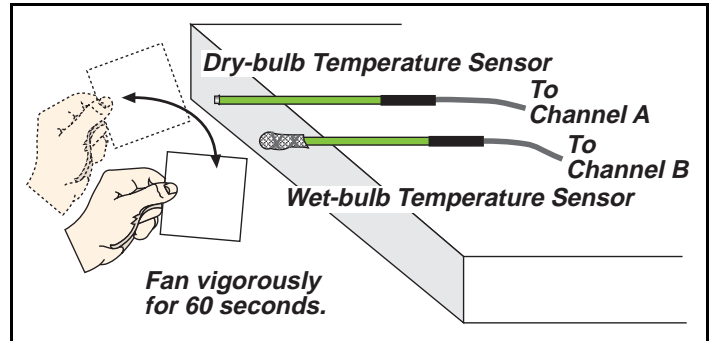

Optional

Set up the *ScienceWorkshop 500* Interface for “data logging”. Carry the interface sensors, fan, and container of water outdoors. Repeat the data recording procedure. Remember, press the LOG button to begin recording data, wait 10 seconds, and then fan vigorously for 60 seconds. Press the LOG button again to end data recording.

Reconnect the interface to the power supply and computer. Download the data from the interface to the computer.

[] D. ANALYZE THE DATA

- Examine each run of data to determine the dry-bulb temperature and the wet-bulb temperature for each run of data. Use the temperatures and the chart in the report to calculate the relative humidity.
- Record your results and answer the questions in the Lab Report.

Report – Activity M08: Relative Humidity

NAME _____
CLASS _____
DATE _____

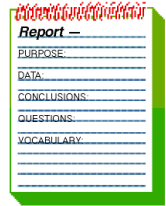

[] What Do You Think?

What is the relationship of humidity to relative humidity? How can relative humidity be determined by measuring temperature?

Answers will vary. Humidity is the amount of water vapor in the air. Relative humidity is the ratio of the mass of water vapor in the air compared to the total mass of water vapor the air can hold at its saturation point. Relative humidity is determined by comparing the dry-bulb temperature to the difference between the dry-bulb temperature and the wet-bulb temperature.

[] Analyze the Data

- For each run of data, write a description of the weather conditions and location for that run of data. Examine the run of data in the Graph and Table displays to determine the dry-bulb temperature and the wet-bulb temperature.

Data Table

Run #	Weather Conditions & Location	Dry-bulb temp (°C)	Wet-bulb temp (°C)
1	Cloudy, overcast	22.0	15.7

- Use the Table of Relative Humidity (attached) to calculate the relative humidity for each run of data.

Run #	Dry-bulb temp (°C)	Difference between wet-bulb and dry-bulb temp	Relative Humidity (%)
1	22.0	6.3	Between 47 and 54

[] Conclusion

Answers will vary. One conclusion is that the temperature difference between the dry-bulb sensor and the web-bulb sensor can be used (along with the chart) to determine relative humidity.

[] Questions

1. How do your answers to the 'What Do You Think?' questions compare to the results?
Answers will vary.
2. What is the difference between *relative humidity* and *specific humidity*?
Relative humidity is the measure of how much water vapor is in the air compared to how much water vapor could be in the air at that temperature. Specific humidity is a measure of the amount of water vapor in a specific volume of air.
3. What causes the difference between the readings of the dry-bulb sensor and the wet-bulb sensor?
The difference in the readings of the dry-bulb sensor and the wet-bulb sensor is caused by the evaporation of water from the end of the wet-bulb sensor. The lower the humidity, the faster the water evaporates and the lower the temperature for the wet-bulb sensor will be.
4. What does it mean to say, "The relative humidity is 60%"?
To say that the relative humidity is 60% means that the amount of water vapor in the air is 60% of the total amount of water vapor the air can hold (saturation) at that temperature.
5. What might cause you to feel hot and uncomfortable on a warm, humid (muggy) day?
On a warm, humid day, the rate of evaporation of water vapor will be slower than on a less humid day. Therefore, sweat will evaporate more slowly (or not at all if the temperature is high enough). Since the evaporation of sweat is a cooling process for the body, if your sweat can't evaporate, you will feel hot!

Complete the following:

VOCABULARY

Humidity: Humidity is the measure of the water vapor in the air.

Psychrometer: A psychrometer is an instrument used to measure relative humidity. It has two temperature sensors (thermometers): one dry-bulb and one wet-bulb.

Relative humidity: Relative humidity is the ratio of the amount of water vapor in the air compared to the amount that would be in the air at its saturation point for a given temperature.

Specific humidity: Specific humidity is a measure of the amount of water vapor in a specific volume of air.

Submit this report to your project manager as soon as possible so it can be forwarded to the Space Agency administrator.

Table of Relative Humidity (in percentage)

Difference between dry-bulb and wet-bulb temperatures (°C)												
Dry temp	1	2	3	4	5	6	7	8	9	10	11	12
0 °C	81	64	46	29	13							
1	83	66	49	33	17							
2	84	68	52	37	22	7						
3	84	70	55	40	26	12						
4	85	71	57	43	29	16						
5	86	72	58	45	33	20	7					
6	86	73	60	48	35	24	11					
7	87	74	62	50	38	26	15					
8	87	75	63	51	40	29	19	8				
9	88	76	64	53	42	32	22	12				
10	88	77	66	55	44	34	24	15	6			
11	89	78	67	56	46	36	27	18	9			
12	89	78	68	58	48	39	29	21	12			
13	89	79	69	59	50	41	32	23	15	7		
14	90	79	70	60	51	42	34	26	18	10		
15	90	80	71	61	53	44	36	27	20	13	6	
16	90	81	71	63	54	46	38	30	23	15	8	
17	90	81	72	64	55	47	40	32	25	18	11	
18	91	82	73	65	57	49	41	34	27	20	14	7
19	91	82	74	65	58	50	43	36	29	22	16	10
20	91	83	74	66	59	51	44	37	31	24	18	12
21	91	83	75	67	60	53	46	39	32	26	20	14
22	92	83	76	68	61	54	47	40	34	28	22	17
23	92	84	76	69	62	55	48	42	36	30	24	19
24	92	84	77	69	62	56	49	43	37	31	26	20
25	92	84	77	70	63	57	50	44	39	33	28	22
26	92	85	78	71	64	58	51	46	40	34	29	24
27	92	85	78	71	65	58	52	47	41	36	31	26
28	93	85	78	72	65	59	53	48	42	37	32	27
29	93	86	79	72	66	60	54	49	43	38	33	28
30	93	86	79	73	67	61	55	50	44	39	36	30
31	93	86	80	73	67	61	56	51	45	40	37	31
32	93	86	80	74	68	62	57	51	46	41	38	32
33	93	87	80	74	68	63	57	52	47	42	39	33
34	93	87	81	75	69	63	58	53	48	43	40	35
35	94	87	81	75	69	64	59	54	49	44	41	36

Teacher's Notes – Activity M08: Relative Humidity

Time Estimates	Preparation: 15 min	Activity: 30 min
-----------------------	----------------------------	-------------------------

Objectives

Students will be able to...

- use two Temperature Sensors (one as a dry-bulb sensor and one as a wet-bulb sensor) to measure the difference in temperature due to humidity
- determine the relative humidity from a standard humidity chart based on their wet-bulb/dry-bulb temperature measurements
- describe how the amount of water vapor in the air determines the difference between the dry-bulb temperature and the wet bulb temperature

Notes

Pre-lab

Put out a large container of water on the day before this activity so it can come to room temperature overnight.

Preparation

Depending on the weather in the part of the world where you are, your students may already be well aware of how unpleasant high humidity can be. Begin the activity with a discussion of how the body sweats to rid itself of excess heat, and how difficult it can be for the sweat to evaporate if the amount of water vapor in the air is near the saturation point for a given temperature.

Safety

Remind students to follow directions for using the equipment.

Setup

The most critical part of the setup is putting the cloth on the end of the wet-bulb Temperature Sensor. Remind your students to make sure that the exposed metal tip of the sensor is covered by damp cloth.

Data Recording

It is very important that the water is at room temperature so the wet-bulb temperature reading is not lower than it should be at the beginning of data recording.

Extensions

One extension is to repeat the data recording out-of-doors.

A second extension is to repeat the data recording on a day that has very different weather from the first day.

A third extension is the measure the relative humidity in a bathroom during a shower.



Setting a Stop Condition

If you don't plan to do "data logging", you can add a 'Stop Condition' to the file so that data recording ends automatically at 60 seconds.

In *DataStudio*, click 'Options' () in the Setup window toolbar. Click 'Time' under 'Stop Condition' and type in '60'. Click 'OK' to return to the Setup window.

In *ScienceWorkshop*, select 'Sampling Options...' from the 'Experiment' menu. Result: The Sampling Options window opens. In the right half of the window, click the radio button in front of 'Time' under 'Stop Conditions'. Result: A second window opens. Type in '60'.

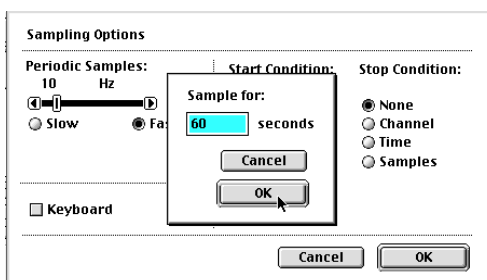
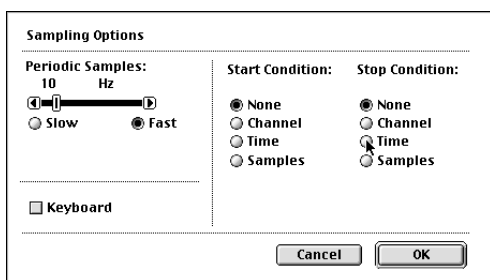
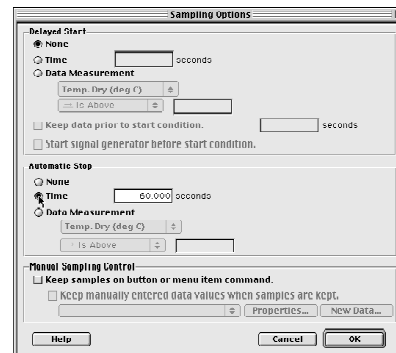

Click 'OK' to return to the Sampling Options window.
Click 'OK' again to return to the Experiment Setup window.

Sample Data

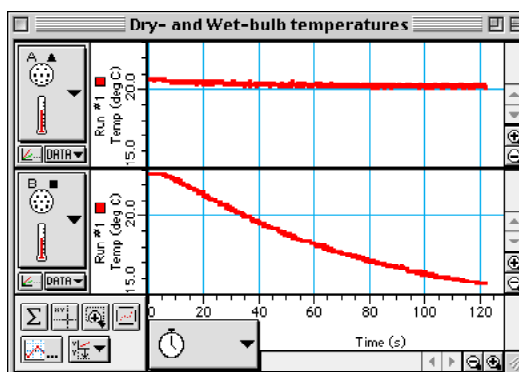
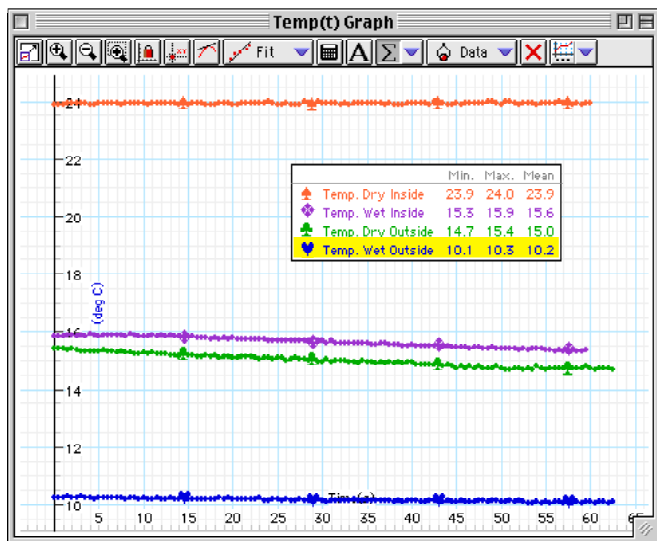



Memorandum — Activity M09: pH of Samples from Other Worlds

To: Space Research Team
From: Joe Venus, Space Agency Administrator
Date: 11 Dec. 2017 AD

Greetings,

A special thanks to your team for the excellent reports on measuring relative humidity with two Temperature Sensors. After reviewing your results, I made a formal recommendation that we *include* the sensors as a backup system. If the recommendation is approved, they will go on the Mission to Other Worlds.

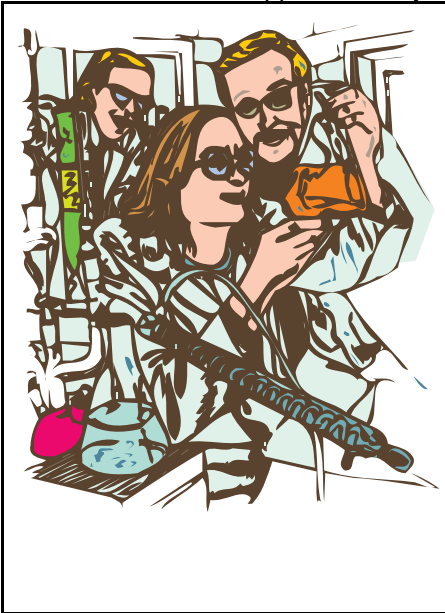

The activities in the last phase of this project deal with making measurements of materials that will be collected on the surface of the alien planet.

An important goal of the Mission to Other Worlds is to test for the presence of life. However, we can't predict what form of alien life we might encounter on the planet we visit. Therefore, we are exploring many different ways for testing for alien life.

We expect that some alien life forms could be like the simpler forms of life here on earth. Our planetary scientists think that these simple alien life forms will have the same basic requirements as simple terrestrial life forms.

One basic requirement of terrestrial life forms is that their environment must have a pH range between 5 and 9 (not too acidic and not too basic). If our robot spacecraft collects soil samples that might contain simple alien life forms, these soil samples will need to be preserved in a substance that has this same pH range – between pH 5 and pH 9.

We need your team to test the pH of several different substances that our planetary scientists are considering for use as preservatives for the collected soil samples. If a substance has a pH value that is outside the safe range, it will be rejected. Your project manager has received a shipment of these substances.

The next section of this Workbook is the *Procedure Outline* for this activity. It will give you some ideas, but, as always, if you can improve on the methods or materials, please do so. Remember, read and heed the *Safety Reminders* in the outline.

Refer to the *Technical Manual* in *Appendix B* of this Workbook for more detailed information on this task.

Please submit your reports to the project manager so the manager can forward them to me.

Yours,

Joe Venus
Space Agency Administrator

Procedure Outline – Activity M09: pH of Samples from Other Worlds

This is a **LAB** activity.

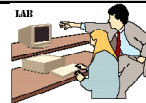

Equipment Needed	Qty	Other	Qty
pH Sensor (CI-6507A)	1	Buffer solution: low pH	100 mL
Beaker, 250 mL	3	Buffer solution: high pH	100 mL
Container for samples (about 200 mL)	4	Distilled water	1 L
Wash bottle	1	Samples (from project manager)	4
Per Student: Protective gear	1 set	Tissues or paper towels	6

VOCABULARY	acid	base	neutral	pH
-------------------	------	------	---------	----

What Do You Think?

What is the pH of several different substances? What is the category for each substance (acid, neutral, or base)?



Take time to answer the 'What Do You Think?' question(s) in the Lab Report section.

One way to classify a substance is to measure whether it is an acid, a base, or is neutral. Acids and bases have been known since early times. An **acid** (from Latin *acidus*, or sharp) has a sharp, sour taste (for example, vinegar). A **base** has a bitter taste and neutralizes the effects of an acid. (Substances that are base are sometimes called “alkaline”.)

Whether a substance is an acid or a base or is neutral can be measured using the pH scale. The **pH** of a solution is a measure of the potential for adding more hydronium (H_3O^+) to the solution. Acid solutions already have a large amount of hydronium in them, so the potential for hydronium, or pH, is very low. Basic solutions have lots of hydroxide (OH^-) ions that would 'soak up' lots of hydronium, so the potential for hydronium is very high.

Most pH values range from 0 to 14.

A pH value of 7 means a **neutral** solution. A pH value below 7 means an acid. A pH value above 7 means a base.

Rainwater is slightly acidic. Blood is slightly basic.

In general, living organisms can tolerate a range of pH values between 5 and 9.

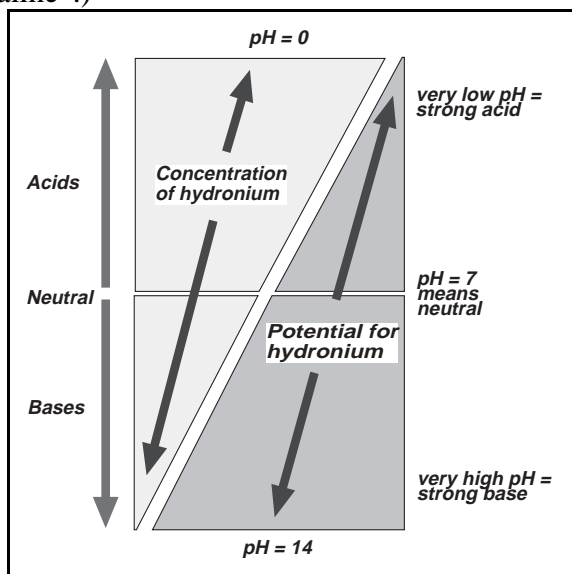

SAFETY REMINDERS (LAB)

- Wear protective gear while handling chemicals.
- Follow directions for using the equipment.
- Dispose of all chemicals and solutions properly.



Procedure Outline

[✓] Remember, for more detailed information see *Appendix B*.

In this activity, use a pH Sensor to measure the pH of several different substances to determine two things about each substance. First, determine whether the substance is acid, base, or neutral. Second, determine whether the substance is within the pH range necessary for living organisms to survive.



[] Pre-Lab: Calibrate the pH Sensor

Use three beakers, the buffer solutions, distilled water, and the wash bottle to calibrate the pH Sensor *before* you use it to measure pH.

NOTE: See *Appendix B* for more information.

1. Connect the pH Sensor DIN plug into Analog Channel A on the *ScienceWorkshop* Interface. Connect the BNC plug to the BNC connector.
2. Set up the equipment to calibrate the pH Sensor. To calibrate the pH Sensor you will need the following: wash bottle, distilled water, three beakers, buffer solutions of high pH (e.g. pH 10) and low pH (e.g. pH 4), pH Sensor.

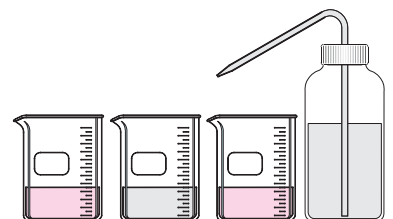

[] A. Set Up the Equipment

1. Put some of the first substance you are going to test in a clean, dry container. Write a description of the substance.
2. Put the pH Electrode into the substance.

[] B. Set Up the Experiment

1. Start *DataStudio* or *ScienceWorkshop* and open the file as follows:

DataStudio	ScienceWorkshop (Mac)	ScienceWorkshop (Win)
M09 pH of Other Worlds.DS	M09 pH Samples	M09_PH.SWS

- The file opens with a Digits display and a Table display of pH. Data recording is set to stop automatically at 30 seconds.

[] C. Do the Experiment

1. Begin recording data. The displays show the pH value for the first chemical. Data recording stops at 30 seconds.
2. After data recording stops, remove the pH Electrode from the sample. Hold the pH Electrode over an empty beaker. Use the wash bottle with distilled water to thoroughly rinse off the pH Electrode. Dispose of the first substance as instructed.
3. Put the second substance into a clean container and measure its pH. Rinse the pH Electrode after you measure the pH.
4. Repeat the process for the other two substances.

[] D. Analyze the Data

1. Use the Table display to examine the pH value of each substance. Determine whether each substance is acid, base, or neutral.
2. Record your conclusions and answer the questions in the Report.

Report – Activity M09: pH of Samples from Other Worlds

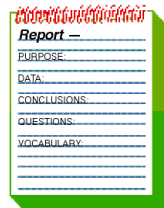

NAME _____

CLASS _____

DATE _____

[] What Do You Think?

What is the pH of several different substances? What is the category for each substance (acid, neutral, or base)?

Answers will vary. Students might predict that substances that are sour will be acid, substances that are bland will be neutral, and substances that are bitter will be base.

[] Analyze the Data

1. For each substance you tested, write a description of the substance. Record the pH value. List whether the substance is acid, base, or neutral..

Data Table

Substance #	Description	pH Value	Acid/Base/Neutral
1	blue colored liquid, perfume-like smell	11	base
2	slightly yellow, thick liquid, no smell	8	weak base
3	clear liquid, vinegary smell	3	acid
4	yellow liquid, lemon smell	2	acid

[] Conclusion

Answers will vary. One conclusion is that the substances with low pH are acids and the substances with high pH are bases.

[] Questions

1. How do your answers to the ‘What Do You Think?’ questions compare to the results?

Answers will vary. _____

2. Which substances are within the pH range necessary for living organisms to survive?

Answers will vary. _____

3. Which substance would you recommend as the *best* substance for storing samples that may contain living organisms?

Answers will vary. _____

Complete the following:

VOCABULARY

acid: An acid is a substance with a low pH value, meaning that its potential for hydronium is low.
--

base: A base is a substance with a high pH value, meaning that its potential for hydronium is high.

neutral: A neutral substance has a pH value of about 7.

pH: The term pH means potential for hydronium or potential for hydrogen and it is an indication of whether a substance is acid, base, or neutral.

Submit this report to your project manager as soon as possible so it can be forwarded to the Space Agency administrator.

Teacher's Notes – Activity M09: pH of Samples from Other Worlds

Time Estimates	Preparation: 15 min	Activity: 30 min
-----------------------	----------------------------	-------------------------

Objectives

Students will be able to...

- calibrate a pH Sensor using two buffer solutions of known pH
- use a calibrated pH Sensor to measure the pH of a variety of substances
- classify the substances by their pH as acid, base, or neutral

Notes

Preparation

Mention that classifying phenomena based on trends and similarities (or differences) is at the heart of scientific analysis.

Get four common substances of different pH. You will need about 100 mL of each substance for each group. For example, if you have eight groups, you will need 800 mL of each substance.

The chart shows the *approximate* pH value of nine substances.

Substance	pH	Type	Substance	pH	Type	Substance	pH	Type
bleach	11	base	egg white (raw)	8	weak base	soda pop	3	acid
milk of magnesia	11	base	tap water	7	neutral	fruit juice	3	acid
detergent (liquid)	10	base	milk	6	weak acid	lemon juice	2	acid

You may want to label the containers for the four substances by number or letter (e.g., “1”, “2” or “A”, “B”).

Buffer Solutions

Flinn Scientific sells various buffer solutions. Vernier Software sells sets of pH Buffer Capsules. Each set contains two capsules for pH buffers 4, 6, and 10 and four capsules for pH buffer 7. These capsules, when added to 100 mL of distilled water, provide reliable buffers for calibrating the pH Sensor.

Contact Vernier Software at (503) 297-5317 (or send a message via fax to (503) 297-1760).

You can prepare pH buffer solutions as follows:

pH 4 Add 2.0 mL of 0.1 M HCl to 1 L of 0.1 M potassium hydrogen phthalate.

pH 7 Add 582 mL of 0.1 M NaOH to 1 L of 0.1 M potassium dihydrogen phosphate.

pH 10 Add 214 mL of 0.1 M NaOH to 1 L of 0.05 M sodium bicarbonate.

Pre-lab

The pH Sensor can be used without calibration, but results will be better if students calibrate the sensor using buffer solutions of known pH value. Review the procedure for calibrating the pH Sensor with your students. (See the Procedure Details for S06 in Appendix A.)

Safety and Disposal

Remind students about safety procedures when using chemicals.

For information on the handling and disposal of chemical solutions, check in the Flinn Scientific catalog. Flinn can be reached at 1-800-452-1261.

Check local regulations about disposing of solutions used in the classroom. All of the substances listed in the chart are commonly poured down sinks into municipal and rural drainage systems.

Data Recording

Remind your students that the file is set to stop recording automatically at 30 seconds.

Some data will probably vary for such chemicals as detergent, fruit juice, soda pop, and tap water.

Extension

One extension is to record data on other liquid samples that the students collect, either from home or from their surroundings.

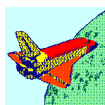

Memorandum — Activity M10: Test for Life — Measure a Chemical Reaction

To: Space Research Team
From: Joe Venus, Space Agency Administrator
Date: 16 Dec. 2017 AD

Greetings,

Thank you for the reports on measuring the pH values of the various substances. After reviewing your results, the planetary scientists decided to recommend the most neutral substance as a preservative. Now the substance will be tested by other research teams for longevity, volatility, etc.

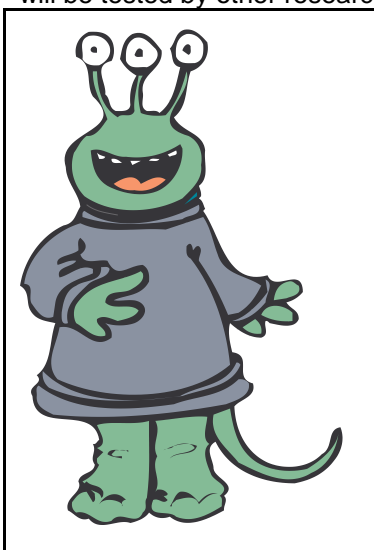
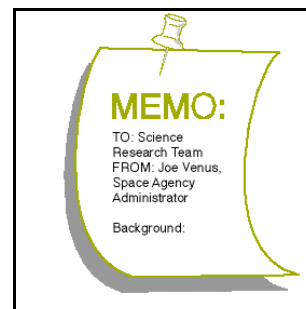

The next activity in this phase of this project involves a different measurement of materials that will someday be collected on the surface of the alien planet.

When the Viking landers arrived on Mars in 1976, their on-board computers directed them to conduct a series of tests to determine whether any organic material was in the Martian soil. A robot arm on each lander scooped up samples of dirt and put small amounts of the dirt into special test chambers on the spacecraft. Each chamber had a different set of instruments for testing for life.

We plan to use a variety of tests for life in our Mission to Other Worlds. One test uses hydrogen peroxide, a very reactive chemical that is used as an anti-infective. Hydrogen peroxide can cause living cells to die. Catalase is an enzyme that can break down hydrogen peroxide into harmless by-products, and most living organisms can produce catalase.

Your team will work on the prototype chamber that will test for living organisms by using hydrogen peroxide. Your project manager has received the prototype chamber and some samples of soil for you to use.

The next section of this Workbook is the *Procedure Outline* for this activity. It will give you some ideas, but, as always, if you can improve on the methods or materials, please do so. Remember, read and heed the *Safety Reminders* in the outline.

Refer to the *Technical Manual* in *Appendix B* of this Workbook for more detailed information on this task.

Please submit your reports to the project manager so the manager can forward them to me.

Yours,

Joe Venus
Space Agency Administrator

Procedure Outline – Activity M10: Test for Life – Measure a Chemical Reaction

This is a **LAB** activity.

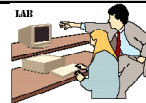

EQUIPMENT	Qty	OTHER	Qty
Pressure Sensor - Absolute (CI-6532)	1	Glycerin	1 mL
Bottle or flask, 250 mL	1	Hydrogen peroxide, 3% solution	50 mL
Connector (included with sensor)	1	Water	150 mL
Graduated cylinder, 100 mL	1	Soil samples (from project manager)	2
Plastic tubing (included with sensor)	20 cm		
Quick-release connector (with sensor)	1	<i>Per Student</i>	Qty
Rubber stopper, 1-hole, to fit bottle	1	Protective gear	1 set

VOCABULARY	catalase	enzyme
-------------------	----------	--------

What Do You Think?

What happens when hydrogen peroxide is mixed with a soil sample that contains organic material that can produce the catalase enzyme?



Take time to answer the 'What Do You Think?' question(s) in the Lab Report section.

Background

Catalase is an **enzyme** that can break down hydrogen peroxide. Hydrogen peroxide is a very active chemical that is often used as an anti-infective. It can poison other chemicals in a living cell causing the cell to die.

Catalase reduces the peroxide part of the hydrogen peroxide molecule into water and oxygen by the following reaction:

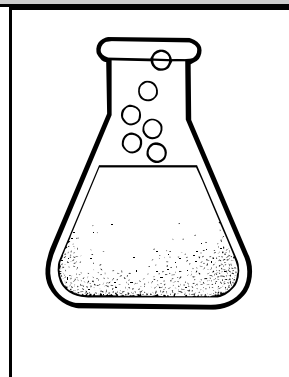
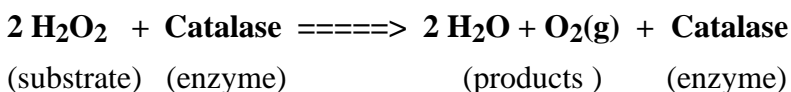

Since catalase is not used up in the chemical reaction, the same enzyme can start another reaction. A substrate-enzyme reaction would cause oxygen to be released. The presence of the enzyme would tend to indicate the presence of a living organism.

SAFETY REMINDERS (LAB)

- Wear protective gear while handling chemicals.
- Follow directions for using the equipment.
- Dispose of all chemicals and solutions properly.



Procedure Outline

[✓] Remember, for more detailed information see **Appendix B**.

In this activity, use a Pressure Sensor to measure the change in gas pressure inside a closed bottle or flask in which a soil sample has been mixed with dilute hydrogen peroxide. Determine whether the soil sample contains organic material that can produce the catalase enzyme.



[] A. Set Up the Equipment

- Put a drop of glycerin on the barb end of a quick release connector. Put the barb end of the connector into one end of a 20 cm long piece of plastic tubing (included with the Pressure Sensor).
- Put a drop of glycerin on the barb end of the connector for the rubber stopper. Put the barb end of the connector into the other end of the plastic tubing.
- Put a drop of glycerin on the larger diameter end of the connector that will go into the rubber stopper, and insert the end into the rubber stopper.
- Align the quick-release connector on the end of the plastic tubing with the connector on the pressure port of the pressure sensor. Push the connector onto the port, and then turn the connector clockwise until it clicks (about one-eighth turn).
- Put 25 mL of 3% hydrogen peroxide in a 100 mL graduated cylinder. Fill the cylinder to the 100 mL mark with 75 mL of water.
- Transfer the diluted peroxide solution to the flask.
- Be ready to put the rubber stopper into the neck of the flask after you add the first soil sample to be tested.
- Connect the Pressure Sensor's DIN plug into Analog Channel A on the interface.

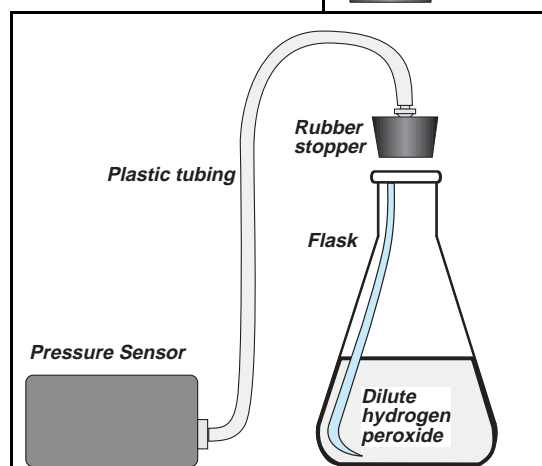
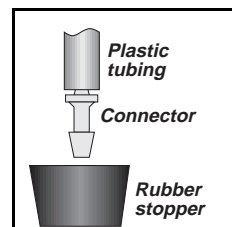
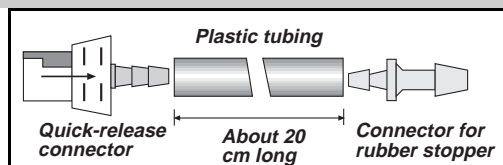

[] B. Set Up the Experiment

- Start *ScienceWorkshop* and open the *ScienceWorkshop* file as follows:

DataStudio	ScienceWorkshop (Mac)	ScienceWorkshop (Win)
M10 Test for Life.DS	M10 Test for Life	M10_LIFE.SWS

- The file opens with a Digits display and a Table display of pressure, and a Graph display of pressure versus time. Data recording is set to stop automatically at 120 seconds.

[] **C. Do the Experiment**

1. Begin recording data.
2. Add the first soil sample to the flask with the dilute hydrogen peroxide and quickly put the rubber stopper into the neck of the flask. Push the stopper in firmly.
3. Swirl the flask to *thoroughly* mix the soil sample into the solution. Hold the stopper down tightly. Data recording stops automatically at 120 seconds.
4. After the first trial, *slowly* remove the rubber stopper to relieve any pressure inside the flask. Empty the flask and rinse it with water.

• Dispose of the soil sample and hydrogen peroxide as instructed.

5. Put 25 mL of 3% hydrogen peroxide in a 100 mL graduated cylinder. Fill the cylinder to the 100 mL mark with 75 mL of water. Transfer the diluted peroxide solution to the flask.
6. Be ready to put the rubber stopper into the neck of the flask after you add the second soil sample to be tested.
7. Begin recording data again and then add the second soil sample to the flask. Repeat the procedure as before. Remember, remove the stopper *slowly* after data recording stops.

[] **D. Analyze the Data**

1. Examine the Table display and the Graph display to determine whether either soil sample had organic material that contained the catalase enzyme.
2. Record your conclusions and answer the questions in the Report.

Report – Activity M10: Test for Life – Measure a Chemical Reaction

Report –
PURPOSE: _____
DATA: _____
CONCLUSIONS: _____
QUESTIONS: _____
VOCABULARY: _____

NAME _____

CLASS _____

DATE _____

[] What Do You Think?

What happens when hydrogen peroxide is mixed with a soil sample that contains organic material that can produce the catalase enzyme?

Answers will vary. Students might predict that the soil samples that contain organic material may bubble when hydrogen peroxide is added.

[] Analyze the Data

- For each soil sample you tested, examine the Table display and the Graph display to determine whether either soil sample had organic material that contained the catalase enzyme.

Data Table

Sample #	Beginning pressure	Final pressure	Change in pressure
1	103 kPa	180 kPa	77 kPa
2	104 kPa	105 kPa	1 kPa

- Sketch the plot of pressure versus time for each soil sample you tested.

- The plot of pressure versus time for the first sample shows an increase in pressure from about 100 kPa to about 180 kPa.
- The plot of pressure versus time for the second sample shows almost no change in pressure.

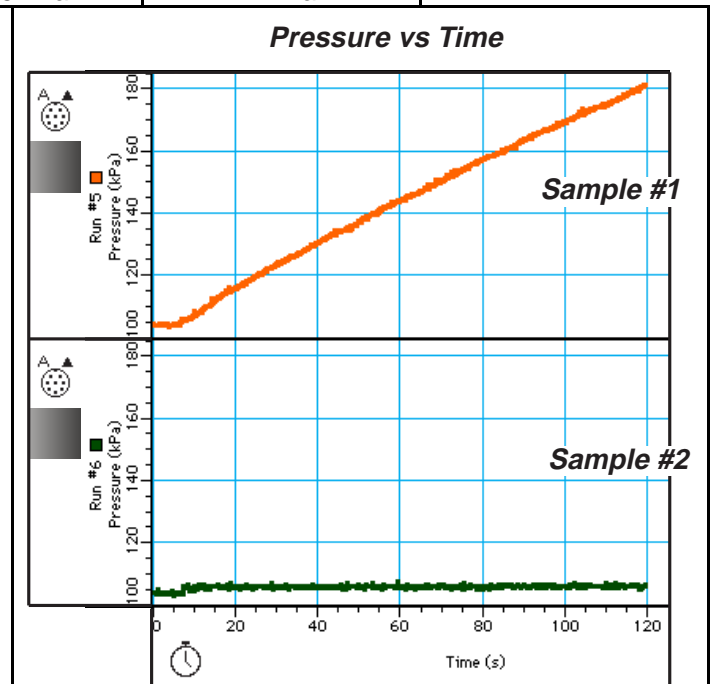

[] Conclusion

Answers will vary. One conclusion is that the first soil sample contains living organisms that produce the catalase enzyme that reacts with hydrogen peroxide to release oxygen gas.

[] Questions

1. How does your answer to the 'What Do You Think?' question compare to the results?

Answers will vary. _____

2. Which soil sample is likeliest to contain organic material that has the catalase enzyme? What evidence is there to support your idea?

The first soil sample is likeliest to contain organic material that has the catalase enzyme. The evidence that supports this idea is that the gas pressure inside the flask increased by almost 80%.

3. What other evidence besides the change in pressure was there to show that a chemical reaction was happening?

Other evidence that a chemical reaction was happening inside the flask was the bubbling inside the flask and the slight warming of the flask.

Complete the following:

VOCABULARY

catalase: Catalase is an enzyme that can react with hydrogen peroxide to break down the hydrogen peroxide, but is not consumed or changed in the reaction.

enzyme: An enzyme is a complex protein produced by living cells that can speed up or induce chemical reactions without itself being permanently altered.

Submit this report to your project manager as soon as possible so it can be forwarded to the Space Agency administrator.

Teacher's Notes – Activity M10: Test for Life — Measure a Chemical Reaction

Time Estimates	Preparation: 60 min	Activity: 30 min
-----------------------	----------------------------	-------------------------

Objectives

Students will be able to...

- use a Pressure Sensor to measure the change in pressure of the gas inside a closed container
- determine whether a gas-producing chemical reaction occurs when a soil sample is mixed with dilute hydrogen peroxide
- conclude whether or not a catalase-producing organism is present

Notes

Soil Sample Preparation

The outline for this activity tells the students/researchers to get two different soil samples from you – the project manager.

Equipment Needed	Qty	Other (per group)	Qty
Balance (SE-8723)	1	Container (for samples)	2
Spoon	1	Sand, dry	9.5 g
Weighing paper	1	Yeast, active, dry	0.5 g

One soil sample is clean, dry sand. It must be as sterile (free of organic materials) as possible.

The other soil sample is clean, dry sand with a small amount of active dry yeast added. The active yeast represents a typical living organism that has catalase - the enzyme that breaks down hydrogen peroxide into water and oxygen. The sand is intended to disguise the presence of the yeast.

When the sand/yeast mixture is added to dilute hydrogen peroxide, the catalase in the yeast breaks down the hydrogen peroxide and releases oxygen gas. If this chemical reaction happens in a closed container, the pressure inside the container increases.

Both the yeast and the hydrogen peroxide must be fresh. Dry active yeast should be refrigerated.

Make two soil samples for each group. Both soil samples should have the same mass. Make one soil sample with 5 g of sand. Make the other soil sample with 0.5 g of yeast and 4.5 g of sand (or one part yeast to nine parts sand).

Mixing a single, large batch of yeast and sand(one part yeast to nine parts sand) may seem more efficient. However, because the yeast and sand have different densities, the sand tends to settle in the container, leaving most of the yeast on the top. It would be difficult to dispense the large batch of yeast and sand in such a way that each portion had the same one-to-nine ratio of yeast to sand.

Safety

SAFETY REMINDERS (LAB)

- Wear protective gear while handling chemicals.
- Follow directions for using the equipment.
- Dispose of all chemicals and solutions properly.



Disposal

Check local regulations about disposing of solutions used in the classroom. The substances used in this activity are commonly poured down sinks into municipal and rural drainage systems.

Data Recording

Remind your students that the file is set to stop recording automatically at 120 seconds.

Also, stress that they need to hold the stopper down tightly using both thumbs. When the yeast/sand mixture is added to the dilute hydrogen peroxide, the pressure inside the flask can increase to almost 200 kilopascals, or two times the normal atmospheric pressure. If the stopper is not held in place firmly, it will pop out of the flask!

Extensions

One extension is to test other organic substances to see whether they contain the catalase enzyme and can cause the hydrogen peroxide to break down. One substance to try is raw chicken or beef liver. Use the juice from the raw liver, or use a mortar and pestle to grind up a small amount of liver with some distilled water. A second substance to test is raw potato. Again, use a mortar and pestle to grind up a small piece of fresh, raw potato with some distilled water.

Another extension is to test saliva. Students may know that saliva contains an enzyme that is essential to the digestive process. Does it also contain catalase?

Sample Data

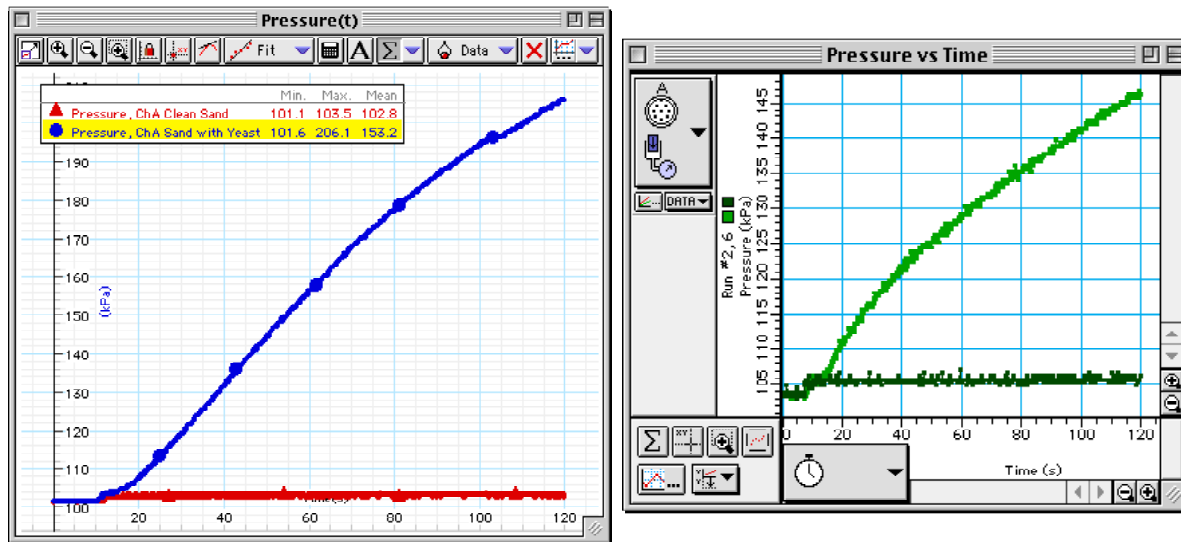

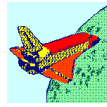

Overview – Appendix B

This appendix for *Part 2: Mission to Other Worlds* of Earth Science Labs with Computers is the technical manual for the activities. For example, the technical manual includes step-by-step instructions for setting up equipment, connecting sensors to the *ScienceWorkshop* interface, or calibrating a sensor.

Use this appendix when you have questions about setting up equipment or recording data for an activity.

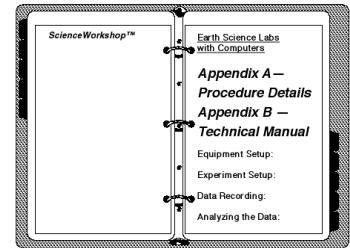

Appendix B Contents

M01	Design and Construct a Model Rocket.....	191
M02	Acceleration of a Model Rocket.....	197
M03	Determine a Space Craft Surface — Heat Transfer	201
M04	Map a Planetary Surface	203
M05	Acceleration of a Falling Object.....	205
M06	Design Landing Bags	209
M07	Temperature at Different Locations.....	213
M08	Relative Humidity	215
M09	pH of Samples from Other Worlds.....	217
M10	Test for Life: Measure a Chemical Reaction.....	221

Technical Manual – Activity M01: Design and Construct a Model Rocket

This part of the Technical Manual (Appendix B) gives information about one way to design and construct a model rocket using a plastic bottle as the fuselage of the rocket, cardboard for fins, and pressurized water for fuel.



Materials

The following is a list of suggested materials and tools for constructing a model rocket using a plastic bottle.

Suggested Materials	Qty	Equipment and Tools	Qty
cardboard sheets, approx. 21 by 28 cm	1 or 2	pencil or pen	1
cardboard tube*, approx. 60 cm long	1	ruler or straight-edge	1
glue	1 tube	scissors	1 pr
newspaper, sheet	several		
plastic sheet, thin, approx. 30 by 30 cm	1	Optional	
plastic soda bottle**	1	<i>hot glue gun</i>	
string	4 m	<i>paint</i>	
tape	1 roll	<i>paint brush or sprayer</i>	

(*The cardboard tube can be smaller in diameter than the plastic soda bottle.)

(**The plastic soda bottle should be between 500 mL and 2 L.)

The basic plan is this:

- use the plastic soda bottle as the engine
- add fins made from the cardboard sheets
- use the cardboard tube as the body, or fuselage
- make a parachute from the thin plastic sheet and string

Construction Ideas

Engine

Some plastic soda bottles come with a plastic base. This is usually glued onto the bottom of the bottle. Remove the plastic base by pulling it off.

You may also want to remove any paper labels from the bottle so it will be easier to add fins. Paper labels can be peeled or scraped off or soaked off with water.

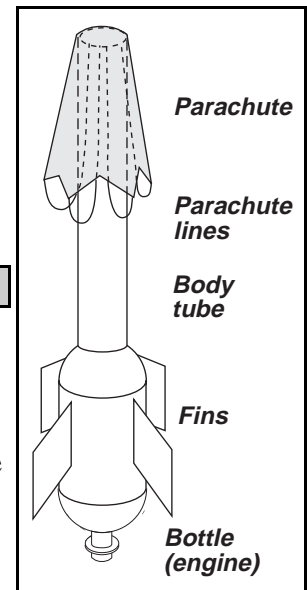

Fins

Fins improve the stability of your rocket. They do not need to be very large in order to help keep the rocket stable in flight. You can experiment with different sizes and shapes.

One possible shape is shown here:

- use one of the cardboard sheets
- draw the pattern for your fins onto the sheet
- cut out the fins

Draw vertical guide lines on the plastic bottle where you want to attach the fins. The lines should be equally spaced around the bottle.

- One method for drawing equally spaced lines requires a pen or pencil, a thin strip of paper, and the edge of a door frame.
- Place the bottle against the edge of a door frame. Draw a line on the bottle using the edge of the door frame as a guide.
- Cut a strip of paper about one inch wide and long enough to wrap at least once around your plastic bottle.
- Put one end of the strip of paper on the guide line on the bottle.

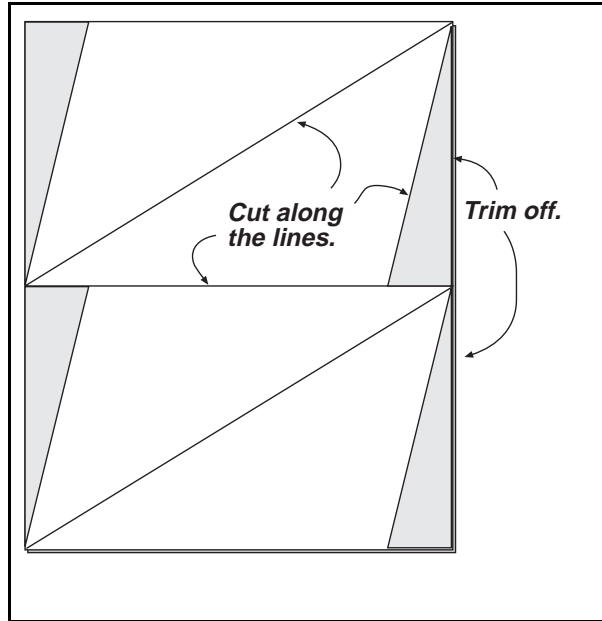

- Wrap the paper strip around the bottle so the end of the strip overlaps the end that is at the guide line.
- Mark the paper strip at the point where it crosses the guide line.
- Cut off the overlap part of the strip.

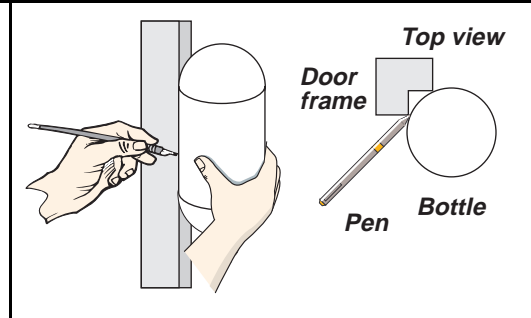

- Fold the remaining part of the strip in half.
- Fold the strip again into quarters.
- Unfold the strip. Mark the creases left by the folding. The strip will now have four equal parts.

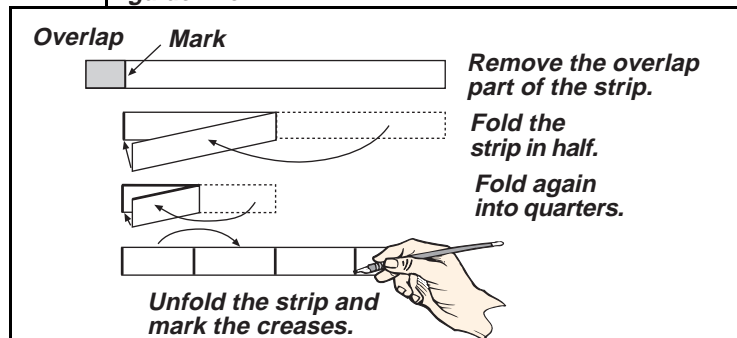
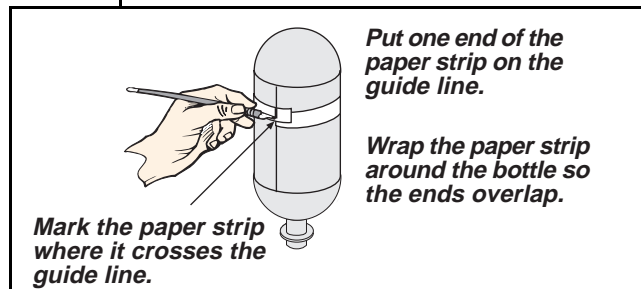

- Put one end of the paper strip on the guide line on the bottle near one end of the bottle. Wrap the paper strip around the bottle so the ends meet on the guide line.
- Put marks on the bottle that match the marks on the paper strip.
- Move the paper strip to the other end of the bottle and make marks that match the marks on the paper strip.
- Place the bottle against the edge of a door frame and line up the marks with the edge of the door frame. Draw a line on the bottle using the edge of the door frame as a guide. Draw the rest of the guide lines in the same way.

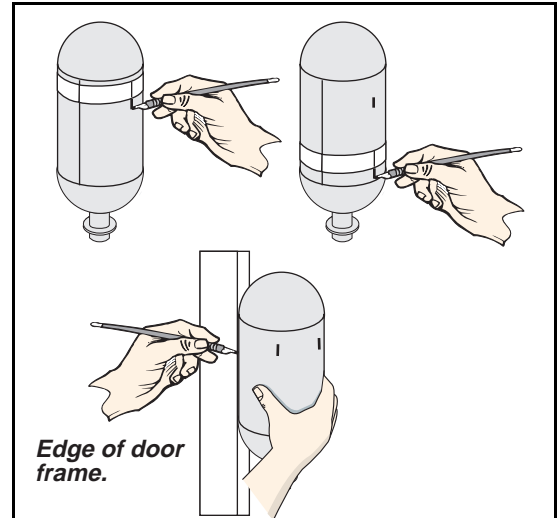

- Glue the fins onto the bottle along the guide lines.
- Use glue and strips of newspaper to reinforce the joints where the fins are glued to the bottle.

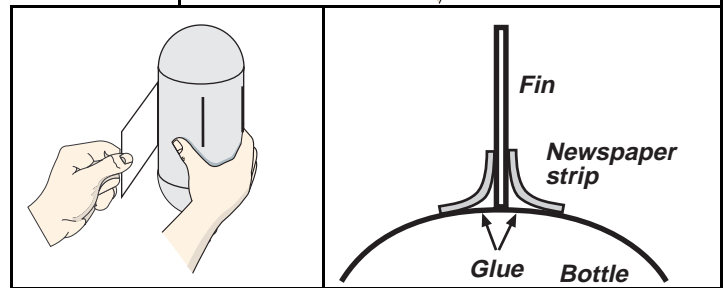

Body

The stability of your rocket also depends on its length. Glue a cardboard tube to the top of the engine (bottle). Use glue and strips of newspaper to reinforce the joint where the body tube is glued to the bottle.

Parachute

The parachute can be made by cutting a circle out of a large plastic bag.

- Fold a square piece of plastic in half, and then into quarters.
- Trim the edges to make a circle.

Cut six lengths of string about 60 cm each. Tape one end of each string to the edge of the plastic circle. Space the strings evenly around the edge of the circle.

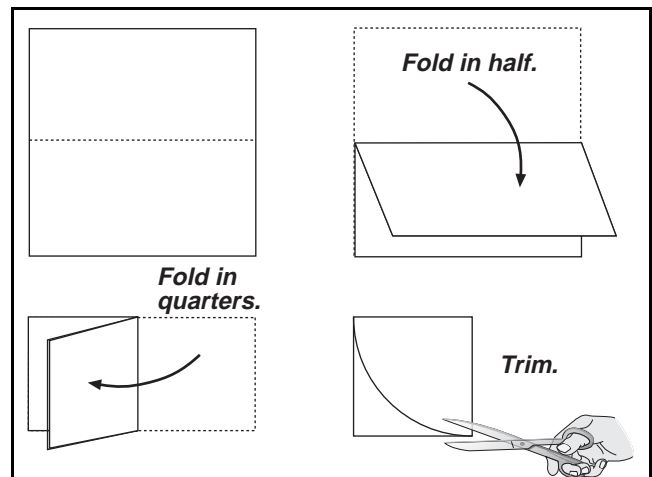

- Tape one end of the first string to the edge of the parachute at one of the fold lines.
- Cut a strip of paper that is the same length as the radius of the circle (center to edge).
- Place the strip of paper so that one end is at the first string. Move the paper so the other end just touches the edge of the circle. Put a mark at the end of the strip.
- Move the paper strip so that one end is at the mark you just made. Adjust the strip so the other end just touches the edge of the circle. Put a mark.
- Repeat the process until you have equally spaced marks on the edge of the circle.
- Tape the ends of the other strings to the marks on the circle.

Tie the ends of the strings together in a knot. Tape or glue the knot inside the top of the body tube.

Drape the parachute over the top of the body tube so the center of the parachute is over the end of the tube.

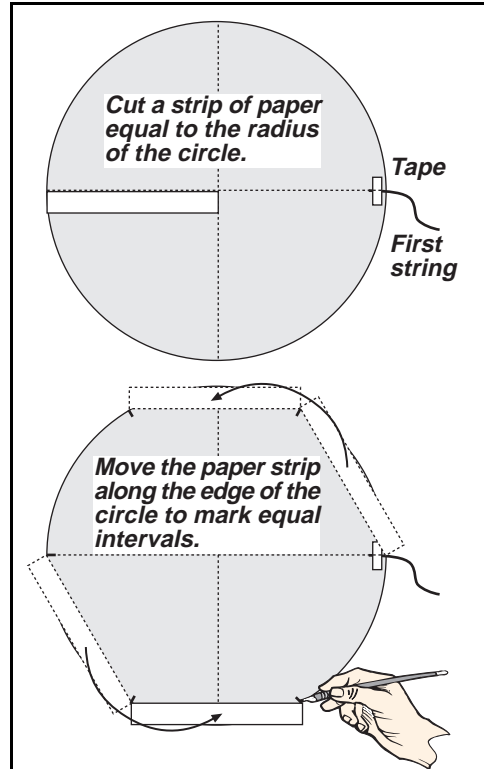

LAUNCHING THE ROCKET

One type of ready-to-use launcher has a rubber stopper that fits into the neck of the bottle. The rubber stopper is attached to an air hose that connects to a bicycle tire pump. The launcher has metal jaws that hold the neck of the bottle. A locking bar keeps the metal jaws in place until it's time to launch. A trigger line pulls the locking bar out.

Prepare the rocket for launching

- Turn the rocket so the neck of the bottle is up. Half fill the bottle with water.
- Put the end of the air hose through the base of the launcher between the arms. Press the rubber stopper firmly into the neck of the bottle. Place the rubber stopper and bottle between the arms of the launcher.
- Each arm of the launcher has a notch in its side. Move the arms so that each notch fits over the neck ring of the bottle. When the arms are in place, put the ends of the locking bar into the holes on the arms.

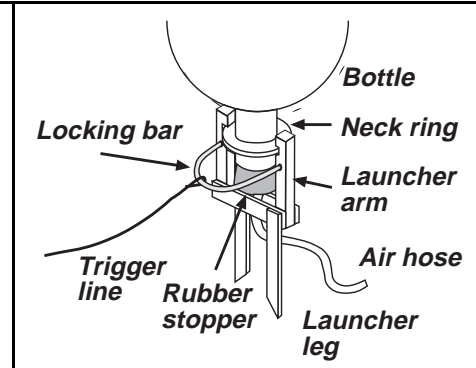
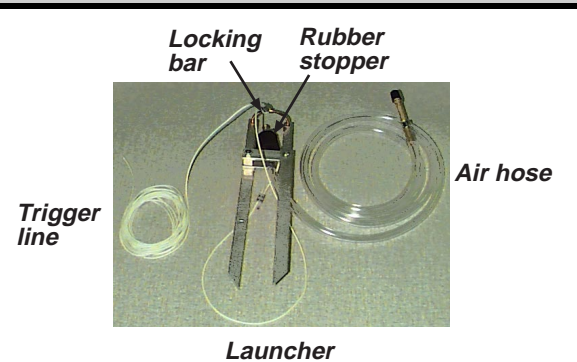

- Take the launcher and rocket to an appropriate launch site. Press the two pointed legs of the launcher into the ground to anchor the launcher in place.
- Push three dowels or sticks into the ground at equal intervals of distance around the side of the rocket to support the rocket.
- Attach the valve stem on the end of the air hose to the bicycle tire pump.
- Pump up the air pressure inside the bottle to 40 pounds per square inch, but no more!

Launch Safety Rules

- Do not pressurize beyond 40 pounds per square inch.
- Do not aim the rocket at anyone, or at buildings or other structures.
- Do not look down at the rocket during pressurization or launch.
- Do not stand within 10 feet of the rocket while launching.

Launch the Rocket

- Stand away from the rocket. Move to a position so you can pull the locking bar using the trigger line. Tighten the trigger line.
- Announce a countdown.
- Give the trigger line a sharp tug to pull out the locking bar.

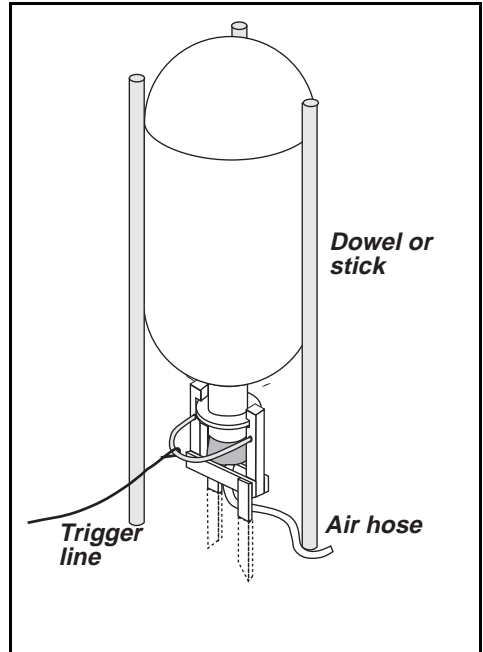

Technical Manual – Activity M02: Acceleration of a Model Rocket

This part of the Technical Manual (Appendix B) gives information about how to use the Motion Sensor to measure the change of velocity (acceleration) of your model rocket.



About the Motion Sensor

The Motion Sensor is designed to measure the position of an object as the object moves. The sensor has a brass colored transducer that creates a burst of ultrasonic pulses.

The burst of ultrasonic pulses travel at the speed of sound toward the object and then “echo” from the object back to the sensor. The software records the time between the pulse going out and the echo returning. The program calculates the distance to the object based on the speed of sound and the recorded time for the pulse to reach the object.

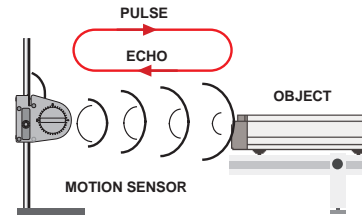

The program records the object’s position many times per second. It uses the difference in position from one moment to the next to determine the object’s speed. It can measure whether the object is moving toward the sensor (negative direction) or away from the sensor (positive direction) to determine the object’s direction of motion. The speed and direction of motion give the object’s velocity. The change in the object’s velocity from one moment to the next is the object’s acceleration.

[] A. Set Up the Equipment

1. Fill the 2 liter containers with water.
2. Get ready to carry the water containers and other equipment (air pump, base & support rod, model rocket & launcher, tire pressure gauge) to the launch site.

[] B. Set Up the Experiment

You can use the *ScienceWorkshop 500* Interface to record data outside of a classroom. You can program the interface while it is connected to the computer, disconnect the interface and go collect data, and then re-connect the interface to the computer to analyze your data.

See Appendix C about using the ScienceWorkshop 500 Interface for “data logging”

1. Start *DataStudio* or *ScienceWorkshop* and open the file as follows:

DataStudio	ScienceWorkshop (Mac)	ScienceWorkshop (Win)
M02 Model Rocket.DS	M02 Acceleration	M02_ACCE.SWS

- Select ‘Open’ from the ‘File’ menu.
- Go to the Experiment Library. Find the document labeled as shown above. Double-click the document filename or select it and click OK or ‘Open’.
- The file opens with a Graph display that shows the position and the velocity of the object being measured.

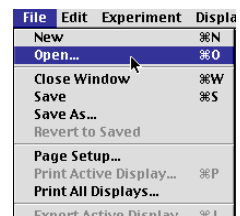

2. Prepare the *ScienceWorkshop* interface for data logging.
 - Make sure that there are four AA alkaline batteries in the interface battery compartment.
 - Make sure that the POWER switch on the back panel of the interface is ON.

3. Set up the software for data logging.
 - In *DataStudio*, click the 'Experiment' menu in the menu bar and select 'Disconnect for

Logging' or click 'Logging' () in the Setup window toolbar. In *ScienceWorkshop*, click the 'Experiment' menu and select 'Disconnect for Logging...".

- In *DataStudio*, a window opens reminding you that you can print an experiment summary if you want. (If your computer is connected to a printer you can print an experiment summary.) After you click 'Yes' or 'No', the software is ready for data logging.

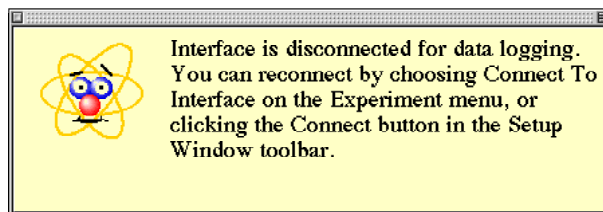
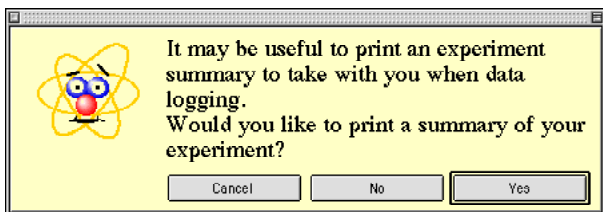

- In *ScienceWorkshop*, the Data Logging Setup window opens. (If your computer is connected to a printer you can print a checklist.) Click 'Begin Logging' when you are ready to begin data logging.

- The interface goes into "sleep" mode. The green light-emitting diode (LED) on the front panel of the interface will go out, and then will blink once every five seconds.

4. Disconnect the interface from the computer. Unplug the power cord and the interface cable from the back of the interface box. (It doesn't matter which is unplugged first).

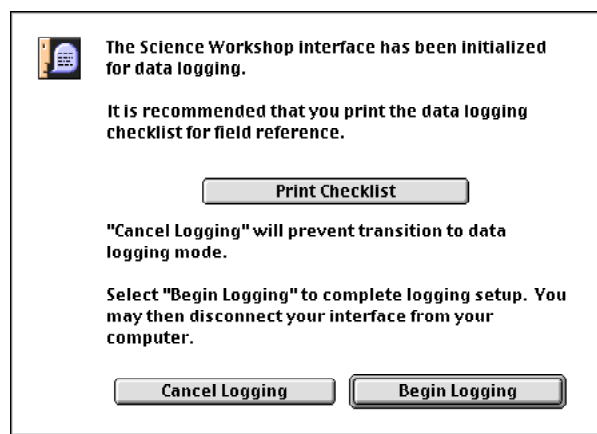

5. Carry the interface and other equipment to the experiment site.

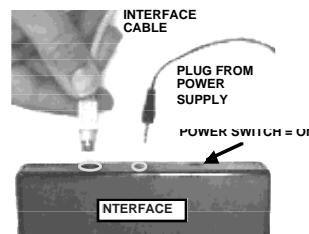

[] C. Do the Experiment

Trial	Amount of Water	Pressure
1	Half-full	40 p.s.i.
2	One-third full	40 p.s.i.
3	Two-thirds full	40 p.s.i.

1. Connect the Motion Sensor plugs into Digital Channel 1 and Digital Channel 2 on the interface box. Mount the Motion Sensor on the support rod.

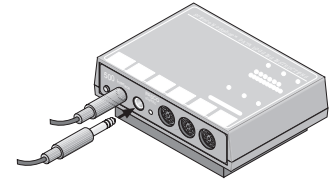

- Connect the plug with the yellow band into Digital Channel 1. Connect the other plug into Digital Channel 2.

2. Put the launcher legs securely into the ground. Add water to the bottle. Push the rubber stopper into the bottle neck and set up your model rocket on the launcher.

- See the Technical Manual for *Activity M01: Design and Construct a Model Rocket*.

3. Set the Motion Sensor and interface about 1 meter from the launch site. Aim the Motion Sensor so that its "line-of-sight" is at the top of the model.

- One way to line up the Motion Sensor is to look at the brass-colored transducer. If you can see the reflection of your eye, then you know where the sensor's "line-of-sight" is located.

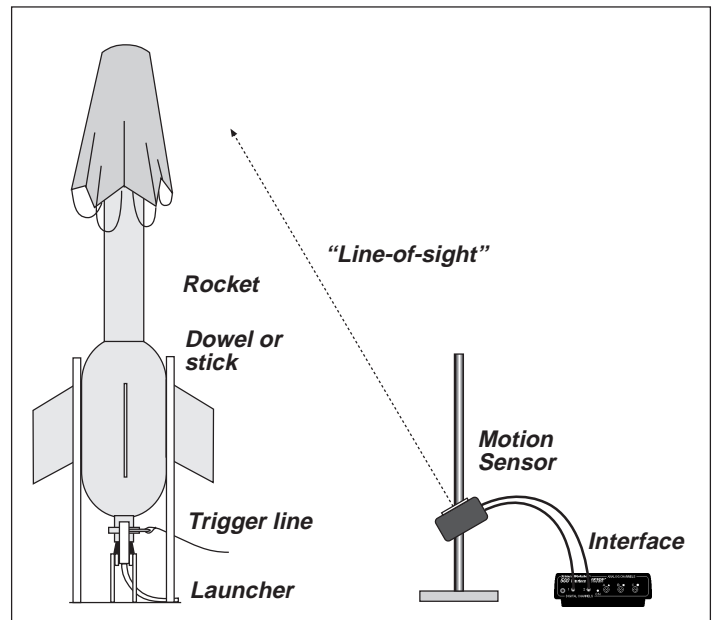
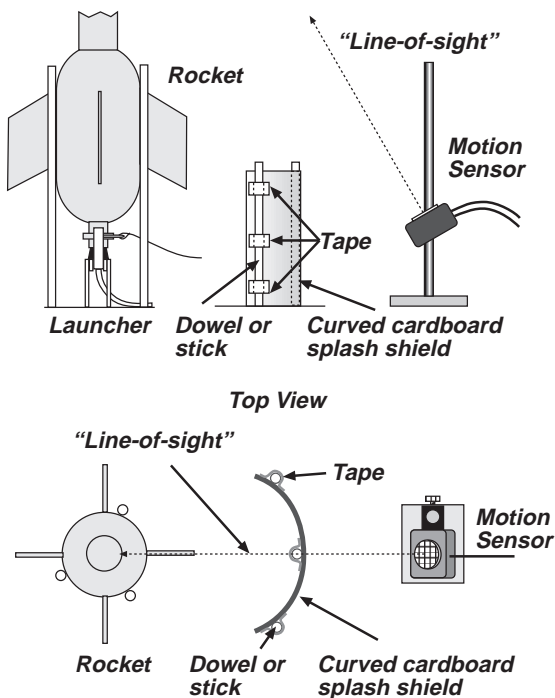

4. Make a curved splash shield and put it between the base of the launcher and the Motion Sensor to protect the sensor from water.



- Use a curved piece of cardboard, three dowels or sticks, and tape to make the shield.

5. Connect the air hose valve stem to your air pump. Pressurize the bottle to 40 pounds per square inch and prepare to launch the rocket.



6. When you are ready, press the LOG button on the front of the interface. Wait ten seconds.
 - The LED on the front of the interface blinks once a second for ten seconds while the interface wakes. The green LED blinks rapidly during data recording.
7. When the LED on the front of the interface begins blinking rapidly, tug sharply on the trigger line to launch the rocket.
8. After the rocket launches, press the LOG button on the front of the interface to stop data recording.
 - The LED goes out and then blinks once every five seconds.
9. Recover the model rocket and repeat the launch procedure, but use *less* water than for the first trial. Recover the model rocket and repeat the launch procedure, but use *more* water than for the first trial.

[] D. Analyze the Data

1. Reconnect the interface to the power supply and computer.
2. Download data from the interface to the computer. (See Appendix C.)
 - In *DataStudio*, select 'Connect to Interface...' in the Experiment menu or click 'Connect' () in the Setup window toolbar. In *ScienceWorkshop*, select 'Connect to Interface' in the Experiment menu. The data will be downloaded automatically.
3. Examine each run of data in the Graph display to determine the acceleration of the model rocket.

- In *DataStudio*, click 'Data' () in the Graph toolbar to select a run of velocity data. In *ScienceWorkshop*, click 'Data' () on the left side of the Graph display or select a run of velocity data the bottom of the Experiment menu.

- In *DataStudio*, click 'Curve Fit' () in the Graph toolbar and select 'Linear'. The slope appears in the Legend box. In *ScienceWorkshop*, click 'Statistics'

() in the lower left corner of the Graph to open the statistics area and select 'Curve Fit, Linear Fit' from the 'Statistics Menu' (). The slope (a2) appears in the statistics area.

4. Record the slope values and write your conclusions and answer the questions in the Report.

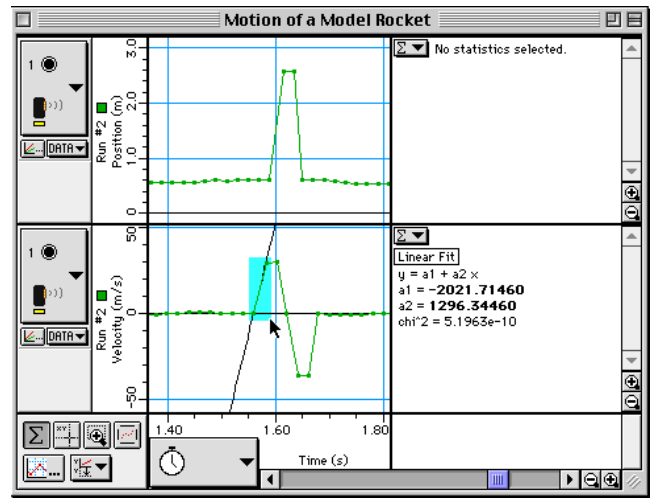

Click-and-draw a rectangle around a region of interest in the velocity plot.

Technical Manual – Activity M03: Determine a Spacecraft Surface

This part of the Technical Manual (Appendix B) gives information about how to use Temperature Sensors to measure the change of temperature of the water in two different aluminum cans.



About the Temperature Sensor

The Temperature Sensor is designed to measure the temperature of water and other liquids. The sensor has a small transistor in its tip that produces a voltage that matches the temperature.

The sensor produces 10 millivolts (0.01 volts) for every degree Celsius of temperature. The program converts the voltage into a digital (numeric) value of temperature.

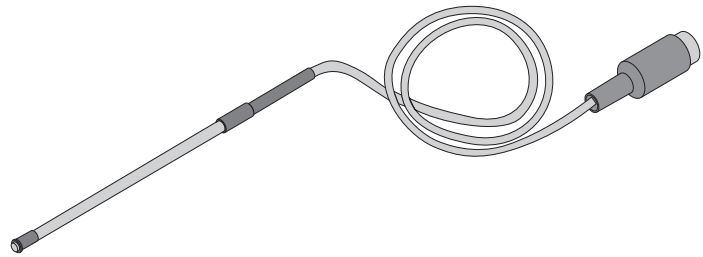

The sensor is covered with protective Teflon except at the very tip. The sensor comes with a separate Teflon cover that can be slipped over the end of the sensor for extra protection from corrosive or caustic chemicals.

[] A. Set Up the Equipment

1. Prepare the two aluminum cans (one shiny and one painted black). Fill each can with the same amount of room temperature water.

- For example, fill each can with 200 mL of room temperature water.

2. Place each can on an insulated pad. Keep the cans away from drafts.

- The insulated pad will reduce the amount of heat transfer through the bottom of each can.

3. Plug in the heat lamp but don't turn it on yet. Place each can so it is the same distance from the front of the heat lamp.

- Use a ruler or metric tape to measure the distance.

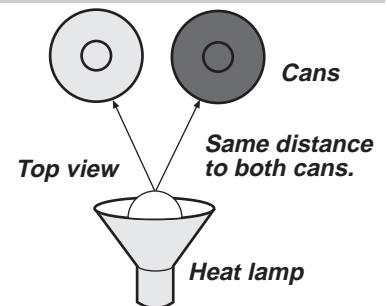

4. Connect one Temperature Sensor into Analog Channel A on the interface. Connect the second Temperature Sensor into Analog Channel B on the interface.

5. Put Temperature Sensor A into the shiny can and put Temperature Sensor B into the dark can.

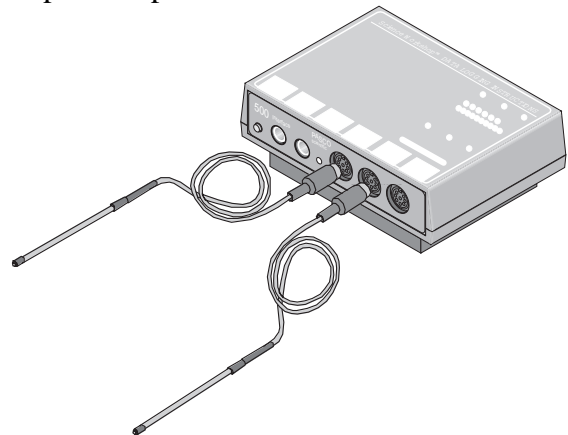

[] B. Set Up the Experiment

1. Start *DataStudio* or *ScienceWorkshop* and open the file as follows:

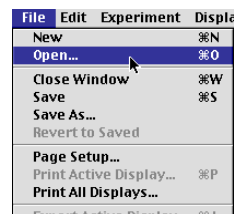

DataStudio	ScienceWorkshop (Mac)	ScienceWorkshop (Win)
M03 Heat Transfer.DS	M03 Heat Transfer	M03_HEAT.SWS

- Select 'Open' from the 'File' menu.
- Go to the Experiment Library. Find the document labeled as shown above. Double-click the document filename or select it and click OK or 'Open'.
- The file opens with a Graph display that shows the position and the velocity of the object being measured.
- You do not need to calibrate the Temperature Sensors.
- The Graph display shows the temperature for both Temperature Sensor A and Temperature Sensor B.





[] C. Do the Experiment

1. Turn on the heat lamp. Be sure that both cans receive the same amount of radiant energy.
2. Begin recording data. Data points will appear on the Graph display every 10 seconds.

- To start data recording, click 'Start' () in *DataStudio* or 'REC' () in *ScienceWorkshop*.
- 3. Swirl the water in both cans continuously for 15 minutes. Data collection stops automatically.
- One way to swirl the water is to stir with the temperature sensors.

[] D. Analyze the Data

1. Use the Statistics area in the Graph display to find the minimum and maximum temperature for each can.
- In *DataStudio*, click 'Statistics' () in the toolbar. 'Minimum' and 'Maximum' are the default selections. . In *ScienceWorkshop*, click 'Statistics' () in the corner of the Graph display. Use the 'Statistics Menu' () to select 'Minimum' and 'Maximum'.
- In *DataStudio*, the minimum and maximum temperatures appear in the Graph Legend. In *ScienceWorkshop*, the minimum and maximum values of "y" appear in the statistics area.
- Subtract the minimum temperature from the maximum temperature.
2. Record your results and answer the questions in the Report.

Technical Manual – Activity M04: Map a Planetary Surface

This part of the Technical Manual (Appendix B) gives information about how to use a Motion Sensor to measure the relative distance from the sensor to objects on a planet's "surface".



NOTE: See the Technical Manual for *Activity M02: Acceleration of a Model Rocket* for information about the sensor.

[] A. Set Up the Equipment

- Make sure that the objects used as features on the surface are less than 1.1 meters tall.

[] B. Set Up the Experiment

See Appendix C for details about using the *ScienceWorkshop 500* Interface for "data logging".

1. Connect the sensor to the interface. Start *DataStudio* or *ScienceWorkshop* and open the file as follows:

DataStudio	ScienceWorkshop (Mac)	ScienceWorkshop (Win)
M04 Map a Planet.DS	M04 Map a Planet	M04_MAP.SWS

- Select Open from the File menu. Go to the Experiment Library.
 - Find the folder or sub-directory for Earth Science.
 - Find the document labeled as shown above. Double-click the document filename or select it and click OK or .
 - The file opens with a Graph display. The file has a pre-made calculation for distance from the sensor to the planetary "surface".
 - The Graph display shows the calculated distances.
2. In the program, prepare the interface to be disconnected for data logging.

Prepare for Data Logging

1. Select 'Disconnect for Data Logging' from the Experiment menu.
- Note: In *DataStudio* you can also click the 'Logging' button in the Experiment Setup window.

Result #1: The interface 'goes to sleep' and the light-emitting diode (LED) on the front panel of the interface blinks once every five seconds.

Result #2: The software shows a reminder window.

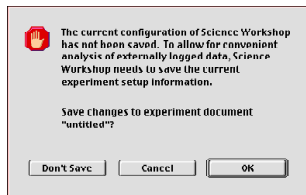
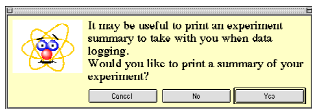
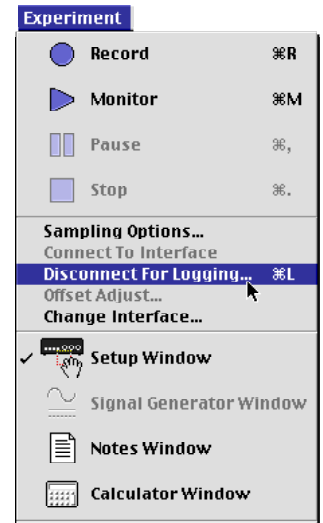
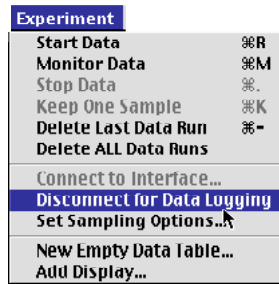

2. Disconnect the interface from the computer and power supply.
 - Unplug the interface cable from the back of the interface. Unplug the power supply from the back of the interface. It doesn't matter which is unplugged first.
 - Be sure to leave the power switch in the ON position.
 - The green light-emitting diode (LED) on the front of the interface will go out, and then it will blink once every five seconds.

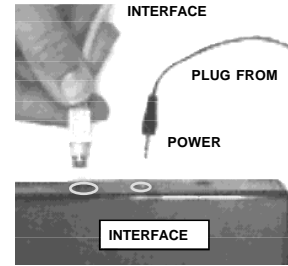

[] C. Do the Experiment

1. Carry the interface and Motion Sensor to the edge of the “planet”. Hold the Motion Sensor about 1.5 meters (5 feet) above the floor. Turn the sensor so it faces the floor.
2. Press the LOG button on the interface to “wake” the interface and begin recording data.
 - The green light-emitting diode (LED) will blink once per second for ten seconds while the interface gets ready to record data. When the green LED begins to blink rapidly, the interface is recording data.
3. Move at a slow, constant speed so the Motion Sensor can record the distance between it and the features of the “planet”.
4. When you reach the end of the landscape, press the LOG button again to stop recording data and return the interface to “sleep” mode.

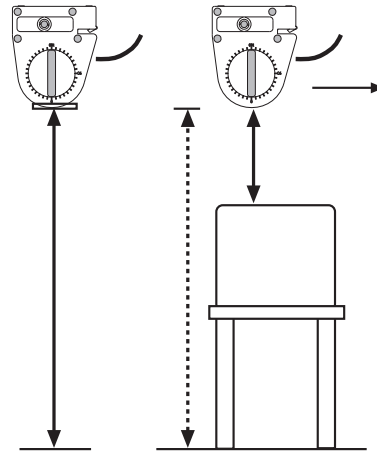

[] D. ANALYZE THE DATA

1. Reconnect the interface to the power supply and computer. Select ‘Connect to Interface’ in the Experiment menu.
 - Note: In *DataStudio* you can also click the ‘Connect’ button in the Experiment Setup window.

Result #1: The data are automatically downloaded. **Result #2:** The LED on the interface stays on.
2. Examine the Graph display to find the minimum, maximum, and mean values for the distances from the sensor to the planet’s surface features.
3. Record your results and answer the questions in the Report.

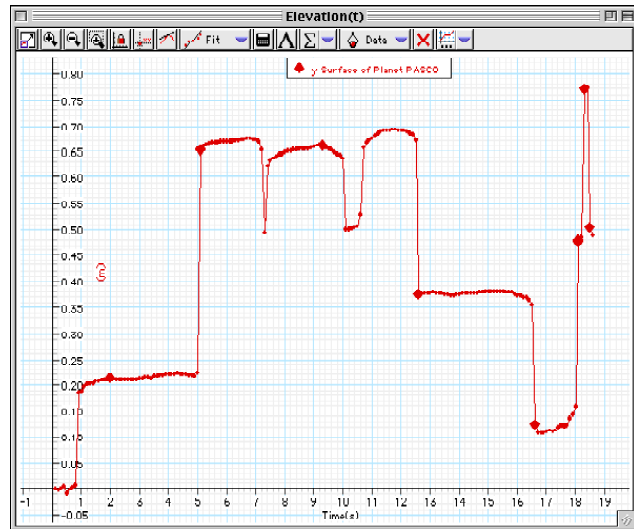

Technical Manual – Activity M05: Acceleration of a Falling Object

This part of the Technical Manual (Appendix B) gives information about how to use a Motion Sensor and the Graph display in to determine the acceleration of an object as it falls, and the acceleration of the object as it hits and bounces on a surface.



NOTE: See the Technical Manual for *Activity M02: Acceleration of a Model Rocket* for information about the sensor.

[] A. Set Up the Experiment

- This setup prepares the Motion Sensor for calibration.
1. Mount the Motion Sensor on the support rod, place the sensor near the edge of a table, and turn the sensor so it is aimed at the floor. Make sure the floor is level.
 2. Use the meter stick to adjust the Motion Sensor so it is exactly 1 meter above the floor or flat, hard surface.

[] B. Set Up the Equipment

1. Connect the sensor to the interface.
 - Plug the modular connector on one end of the interface cable into the side of the Motion Sensor. Connect the stereo phone plugs of the Motion Sensor to Digital Channels 1 and 2 on the interface. Connect the yellow plug to Digital Channel 1 and the other plug to Digital Channel 2.

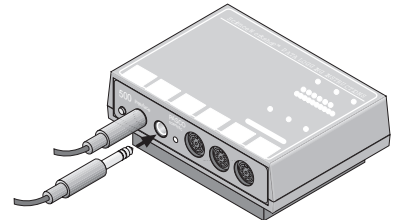

2. Start *DataStudio* or *ScienceWorkshop* and open the file as follows:

DataStudio	ScienceWorkshop (Mac)	ScienceWorkshop (Win)
M05 Falling Object.DS	M05 Free Fall & Bounce	M05_BOUN.SWS

- Select Open from the File menu.
- Go to the Experiment Library.
- Find the document labeled as shown above. Double-click the document filename or select it and click OK or .

[] **Pre-Lab: Calibrate the Motion Sensor**

3. In the Experiment Setup window, double-click the sensor's icon.
 - **Result:** In *DataStudio*, the Sensor Properties window opens.
Click the 'Motion Sensor' tab. **Result:** The calibration window opens and the sensor begins to click a few times per second.
 - **Result:** In *ScienceWorkshop*, the sensor's calibration window opens and the sensor begins to click a few times per second.

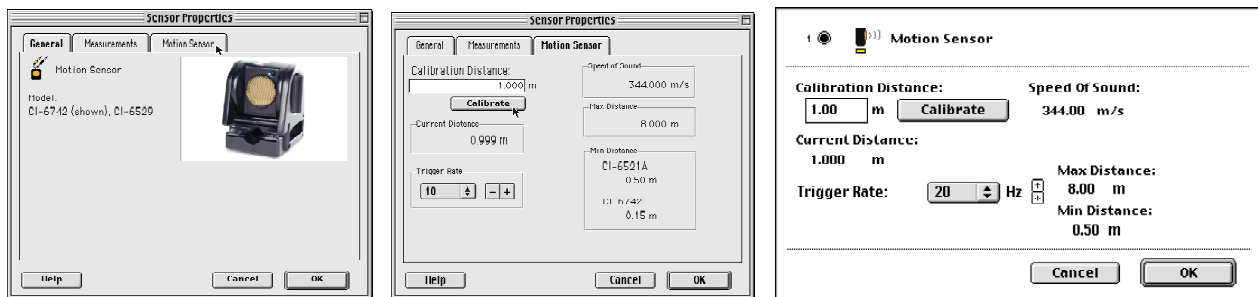

4. Calibrate the software.
 - **First**, make sure that the sensor is one meter from the target.
 - **Second**, click the 'Calibrate' button in the Motion Sensor window. **Result:** The software calculates the speed of sound based on the calibration distance (one meter) and the round trip time of the pulse and echo
5. Click 'OK' to return to the Experiment Setup window.

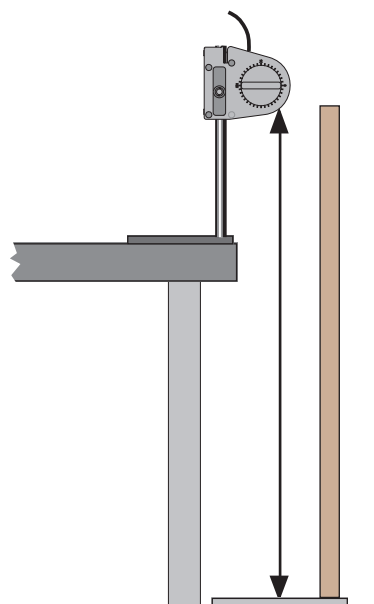

[] **C. Do the Experiment**

1. To start recording data, click 'Start' in *DataStudio* or 'REC' in *ScienceWorkshop*.
2. Begin data recording and then drop the ball. Let the ball bounce several times.
 - **Remember:** Be sure to move your hand out of the way as soon as you release the ball.
3. After the ball has bounced several times on the floor, stop the data recording.
 - Click 'Stop' to stop recording.
 - If you want to delete a trial of data because a hand was in the way or the ball did not bounce very well, go to the Data list in *DataStudio* or *ScienceWorkshop*. Click the trial of data in the Data list to highlight the data run.
 - Press the <delete> key on the keyboard. An alert window will open asking "Are you sure you want to delete the selected data?"
 - Click OK to delete the data and return to the Setup window.

[] D. Analyze the Data

- The position plot of the Graph shows a “mirror image” of a ball bouncing on a flat surface.
- 1. Use the built-in analysis tools in the Graph display to determine the acceleration of the ball as it falls.
- Rescale the Graph display to fit the data so you can see two or three ‘bounces’.

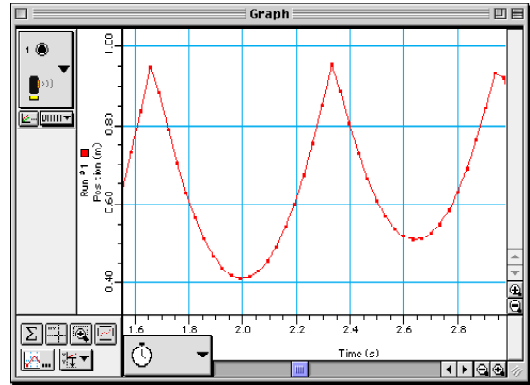
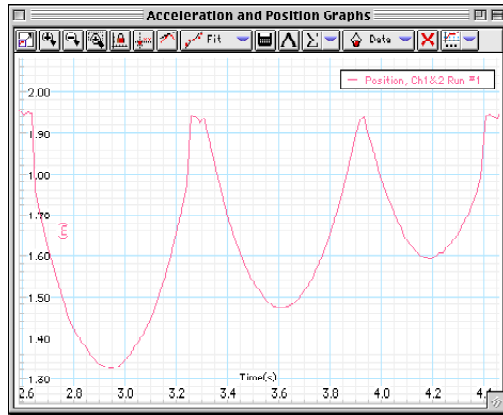

- Move the analysis tool to one of the ‘flat’ regions in the *acceleration* plot. Read and record the value of acceleration. (Hint: In *DataStudio*, the acceleration is the ‘y’ coordinate. In *ScienceWorkshop*, the acceleration is shown along the vertical axis.)

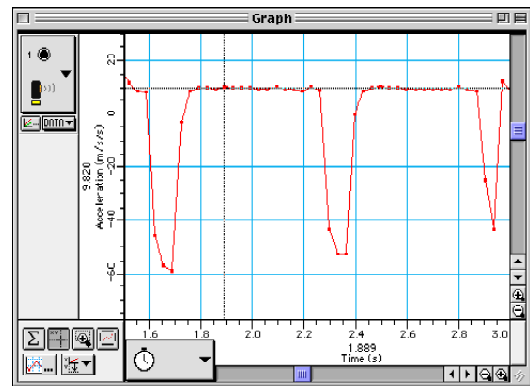
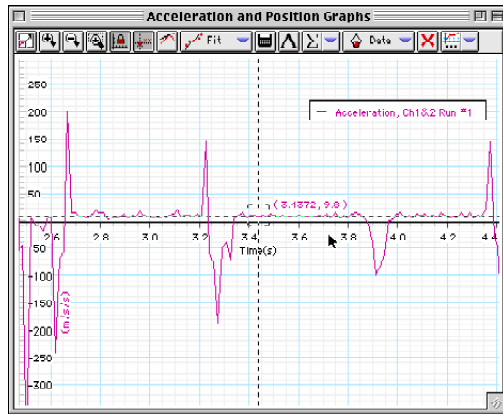

2. In the acceleration plot, use the 'Smart Tool' (*DataStudio*) or the 'Smart Cursor' (*ScienceWorkshop*) to find the maximum acceleration each time the ball bounces.

 - Move the analysis tool so it is at the lowest point for one of the 'bounces' on the plot of acceleration.
 - Read and record the value of acceleration.

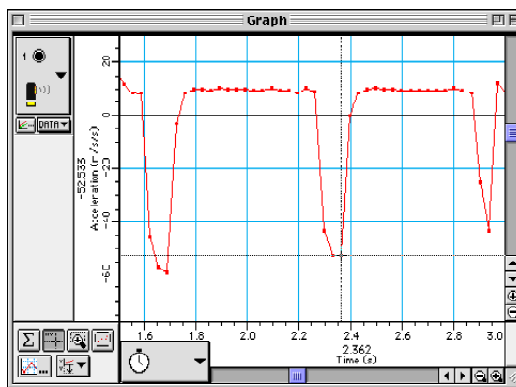
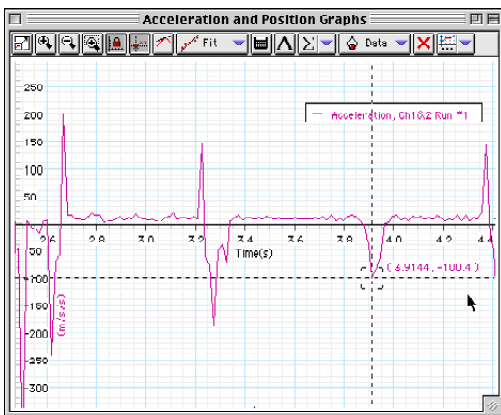

3. Record your data and answer the questions in the Report.

Technical Manual – Activity M06: Design Landing Bags

This part of the Technical Manual (Appendix B) gives information about how to use a Pressure Sensor and the Graph display to determine the relationship of pressure and volume of a gas as the volume of the gas is altered.



About the Pressure Sensor

The Pressure Sensor uses a MPX700 transducer. This type of transducer has two ports, but there is a permanent reference vacuum cell sealed to one port of the transducer. The other port is open to the atmosphere.

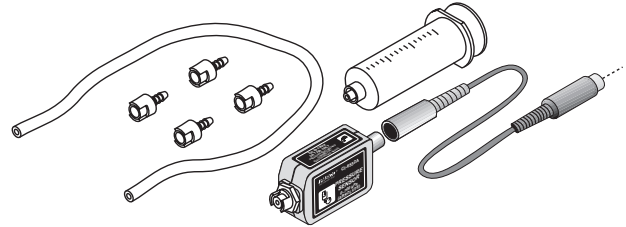

The sensor consists of the electronics box with a cable for connecting to the computer interface. The port that is open to the atmosphere has a “quick-release” style connector. The transducer is durable, but it is designed to be used with non-corrosive gases such as air, helium, nitrogen, etc. Do not let the transducer get wet.

[] A. Set Up the Equipment

1. Be very careful when cutting the piece of plastic tubing. Use the shortest length of tubing that you can so there is a minimum amount of extra air.
 2. The glycerin lubricates the tubing so it can slip onto the syringe and the connector.
- You may need to disconnect the plastic tubing from the sensor in order to pull the piston back out to the 20 mL mark. To disconnect the tubing, turn the quick-release connector about one-eighth turn counter-clockwise and pull the connector away from the sensor. Reverse the steps to re-connect the tubing after you pull the piston back to 20 mL.

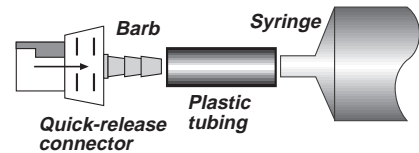

[] B. Set Up the Experiment

1. Connect the sensor to the interface. Put the sensor cable's DIN plug into Analog Channel A on the interface. Connect the other end of the cable into the sensor.
2. Start the program and open the file as follows:

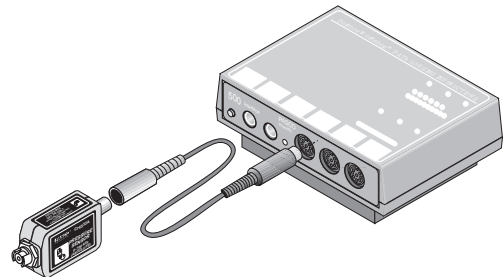

DataStudio	ScienceWorkshop (Mac)	ScienceWorkshop (Win)
M06 Landing Bags.DS	M06 Airbags	M06_BAG.SWS

- Select Open from the File menu.
- Go to the Experiment Library.
- Find the document labeled as shown above. Double-click the document filename or select it and click OK or .
- The file opens with a Graph display, a Table display, and a Digits display. You will use the keyboard to type in the amount of volume as you change it.

[] C. Do the Experiment

1. One person can type in the amount of volume while a second person pushes on the syringe to change the volume.
2. When you start recording data, the Table in *DataStudio* shows the pressure in the first cell of one column, and the volume's first value (20 mL) in the second column. In *ScienceWorkshop*, the 'Keyboard Sampling' window opens.

*Pressure, ChA Run #1	*Syringe Volume Run #1
Pressure (kPa)	(ml)
101.566	20.000

Volume (ml)

Entry # 1

Buttons: Delete, Enter, Stop Sampling

3. In *DataStudio*, click 'Keep' to record the pressure. Press <return> or <tab> to move to the next cell in the Table. **Result:** The Table display changes to show the next value of volume (18 mL). In *ScienceWorkshop*, type in '20' and click 'Enter' to record the pressure and volume. **Result:** The first entry appears in the list, and 'Entry #2' shows a new default value.

*Pressure, ChA Run #1	*Syringe Volume Run #1
Pressure (kPa)	(ml)
101.566	20.000
114.750	18.000

Volume (ml)

#1 20.0000

Entry # 2

Buttons: Delete, Enter, Stop Sampling

4. Move the piston to the 18 mL mark. Click 'Keep' in *DataStudio*. In *ScienceWorkshop*, type in '18' and click 'Enter'.
5. Continue the procedure until you reach 10 mL.

[] **D. Analyze the Data**

1. Use the Graph display to determine the relationship of the pressure and volume of the air.
 - Will the relationship between the volume and the pressure be a direct one or will it be something else? The shape of the plot of two quantities can tell what their relationship might be.
 - Here are two examples of relationships:

Direct Relationship

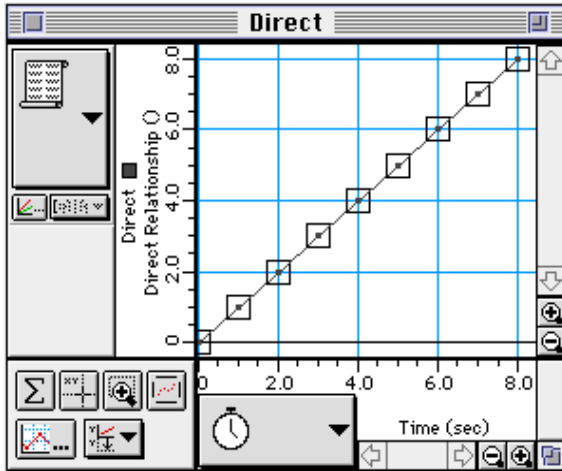

Inverse Relationship

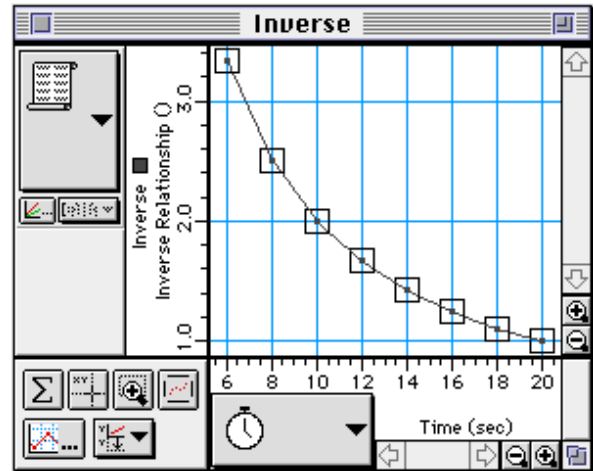

2. Record your results and answer the questions in the Report.

Technical Manual – Activity M07: Temperature at Different Locations

This part of the Technical Manual (Appendix B) gives information about how to use the Temperature Sensor to determine the temperature at several different locations.



NOTE: See the Technical Manual for *Activity M03: Determine a Spacecraft Surface - Heat Transfer* for information about the sensor.

[] A. Set Up the Equipment

1. Connect the sensor's DIN plug into Analog Channel A on the interface.

[] B. Set Up the Equipment

You can use the *ScienceWorkshop 500* Interface to record data outside of a classroom.

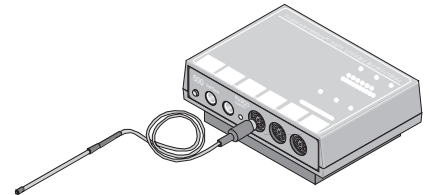

See Appendix C about using the ScienceWorkshop 500 Interface for "data logging"

1. Start *DataStudio* or *ScienceWorkshop* and open the file as follows:

DataStudio	ScienceWorkshop (Mac)	ScienceWorkshop (Win)
M07 Location Temp.DS	M07 Remote Temperature	M07_REMO.SWS

- Select Open from the File menu.
- Go to the Experiment Library.
- Find the document labeled as shown above. Double-click the document filename or select it and click OK or .

2. Prepare the *ScienceWorkshop* interface for data logging.

- Make sure that there are four AA alkaline batteries in the interface battery compartment.
- Make sure that the POWER switch on the back panel of the interface is ON.

3. Set up the software for data logging.

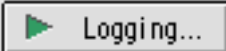
- In *DataStudio*, click the 'Experiment' menu in the menu bar and select 'Disconnect for Logging' or click 'Logging' () in the Setup window toolbar. In *ScienceWorkshop*, click the 'Experiment' menu and select 'Disconnect for Logging...".

- In *DataStudio*, a window opens reminding you that you can print an experiment summary if you want. (If your computer is connected to a printer you can print an experiment summary.) After you click 'Yes' or 'No', the software is ready for data logging.

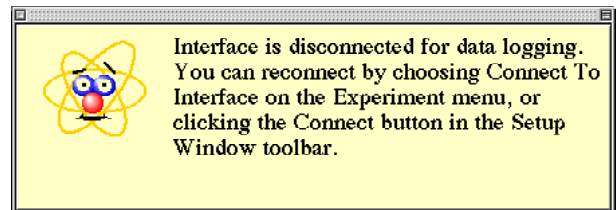
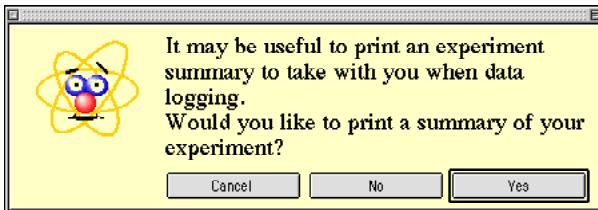

- In *ScienceWorkshop*, the Data Logging Setup window opens. (If your computer is connected to a printer you can print a checklist.) Click 'Begin Logging' when you are ready to begin data logging.

- The interface goes into "sleep" mode. The green light-emitting diode (LED) on the front panel of the interface will go out, and then will blink once every five seconds.

4. Disconnect the interface from the computer. Unplug the power cord and the interface cable from the back of the interface box. (It doesn't matter which is unplugged first).

5. Carry the interface and sensor to the first location site.

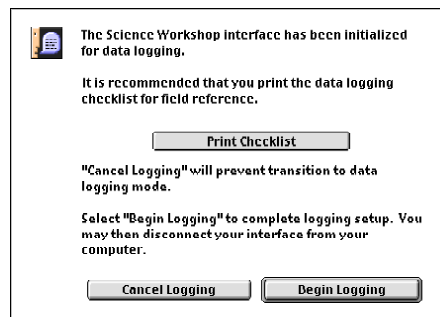

[] C. Do the Experiment

1. Place the Temperature Sensor so its tip is against a surface that is exposed to direct sunlight. When you are ready to begin the experiment, press the LOG button on the interface to wake the

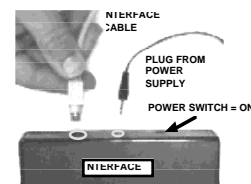

- On a bright day, you may need to shield the LED with your hand in order to see it blink.

2. Leave the Temperature Sensor in the contact with the surface that is in the sunlight for about sixty seconds. Press the LOG button again to stop recording data.

- One team member can serve as the "official timekeeper" to keep track of the amount of time that data should be recorded.

Optional

If there is a shallow puddle of water near some bare ground, measure the temperature of the water and the temperature of the bare ground next to the water.

- If the ground is very hard, use a tool to loosen the soil before you put the tip of the Temperature Sensor into it.

[] D. ANALYZE THE DATA

1. Reconnect the interface to the power supply and computer. Download the data.

- Select 'Connect to Interface' in the Experiment menu. The data will be downloaded automatically.

2. Examine each run of data to determine the minimum, maximum, and mean value of temperature for each location and condition.

- Use the display's Statistics menu to select 'Minimum', 'Maximum', and 'Mean'.

3. Record your results and answer the questions in the Report.

Technical Manual – Activity M08: Relative Humidity

This part of the Technical Manual (Appendix B) gives information about how to use Temperature Sensors and the Graph and Table displays to determine relative humidity.



NOTE: See the Technical Manual for *Activity M03: Determine a Spacecraft Surface - Heat Transfer* for information about the sensor.

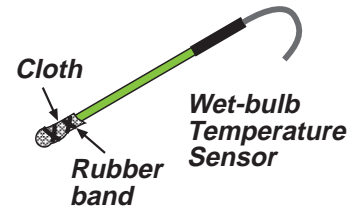

[] A. Set Up the Equipment

1. Wrap the piece of cheesecloth or light cotton material around the end of one of the Temperature Sensors.
 - Make sure the tip of the sensor is covered completely by one layer of the cloth.

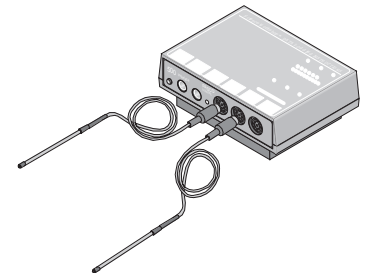

2. Connect the dry-bulb Temperature Sensor's DIN plug into Analog Channel A on the interface. Connect the wet-bulb Temperature Sensor's DIN plug into Analog Channel B on the interface.
3. Put *room temperature* water into a container.
 - Fill the container early and let it sit in the room until its temperature reaches room temperature.
 - One way to keep track of its temperature is to use the dry-bulb sensor. Hold the sensor in the air so its tip does not touch anything. In *DataStudio*, select 'Monitor Data' from the Experiment menu. In



- 
- ScienceWorkshop*, click the 'MON' () button. Watch the Digits display to see the room temperature. Now put the end of the sensor in the water and watch the Digits display to see the water's temperature.
- If you do not have time to wait, add a small amount of warm water to raise the temperature, or add a small amount of cold water to lower the temperature. Add the water slowly and stir the water with the sensor. When the water's temperature is near room temperature, stop adding the extra water. Click the STOP button.

[] B. Set Up the Experiment

1. Start *DataStudio* or *ScienceWorkshop* and open the file titled as shown:

DataStudio	ScienceWorkshop (Mac)	ScienceWorkshop (Win)
M08 Humidity.ds	M08 Humidity	M08_HUMI.SWS

- Select Open from the File menu.
- Go to the Experiment Library.
- Find the document labeled as shown above. Double-click the document filename or select it and click OK or .

[] C. Do the Experiment

1. Place both Temperature Sensors near the edge of a table so the ends of both sensors extend beyond the edge of the table.

- You may want to use pieces of tape to hold the sensors in place on the table.

2. Moisten the cheesecloth with *room temperature* water.

3. Begin data recording.

- Click 'Start' in *DataStudio* or 'REC' in *ScienceWorkshop*.

4. Stop data recording after 60 seconds.

- Watch the horizontal (x) axis of the Graph display to keep track of time. Click the STOP button at 60 seconds.

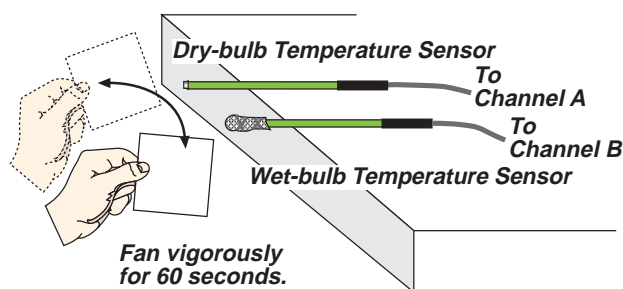

Optional

Set up the *ScienceWorkshop* 500 Interface for “data logging”.

NOTE: See the Technical Manual for *Activity M07 - Temperature at Different Locations*.

Carry the interface sensors, fan, and container of water outdoors. Repeat the data recording procedure. Remember, press the LOG button to begin recording data, wait 10 seconds, and then fan vigorously for 60 seconds. Press the LOG button again to end data recording.

[] D. Analyze the Data

1. Examine each run of data in the Graph and Table displays to determine the dry-bulb temperature and the wet-bulb temperature for each run of data. Use the temperatures and the chart in the report to calculate the relative humidity.

- Use the 'Data' menu to select a run of data. In *DataStudio*, click the 'Data' menu in the Table display toolbar. In *ScienceWorkshop*, click the 'Data' menu on the left side of the display.

- Use the built-in statistics of the Table display to find the minimum, maximum, and mean of the temperature. In *DataStudio*, use the 'Statistics' menu in the Table toolbar. In *ScienceWorkshop*, click the 'Statistics' button on the left side of the Table display to open the statistics area at the bottom of the display. The minimum (Min), maximum (Max), mean (Mean), and standard deviation (Std Dev) are shown in the statistics area.

2. Record your results and answer the questions in the Report.

Technical Manual — Activity M09: pH of Samples from Other Worlds

This part of the Technical Manual (Appendix B) gives information about how to use a pH Sensor and the Digits displays in the software to determine the pH of several unknown substances.

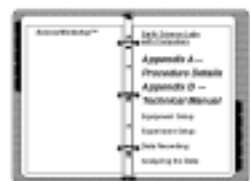

This part of the manual also gives information about how to calibrate the pH Sensor before using it to make measurements.

About the pH Sensor

The pH Sensor is designed to measure the pH (“potential of hydrogen”) of a liquid.

The sensor has two parts: a pH Electrode and an Amplifier. The pH Electrode has a BNC plug on its cable that connects to the BNC connector on the Amplifier. The Amplifier has a DIN plug and a cable that connects to the interface.

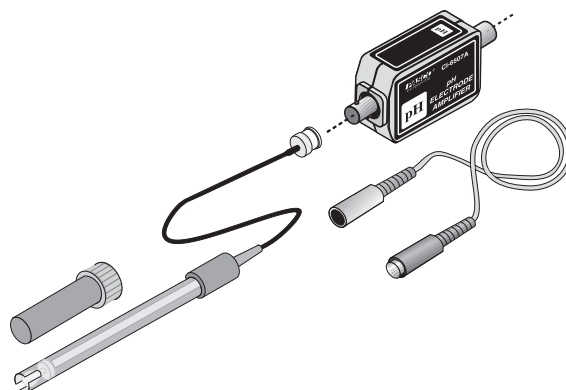

The pH Electrode produces a voltage proportional to the hydrogen ion concentration (“potential of hydrogen” or pH) in a solution. The voltage changes 0.1 volts for each pH number. The pH Amplifier has a very high input impedance.

The end of the pH Electrode is stored in a small plastic container that contains a buffer solution made with 1 gram of potassium chloride (KCl) added to 100 mL of pH 4 buffer solution.

[] A. Set Up the Equipment

1. Put some of the first substance you are going to test in a clean, dry container. Write a description of the substance in your report.
2. Put the pH Electrode into the substance.

[] B. Set Up the Experiment

1. Plug the DIN connector cable into the sensor’s DIN plug and then connect the cable into Analog Channel A on the *ScienceWorkshop* interface.
2. Start *DataStudio* or *ScienceWorkshop* and open the file as follows:

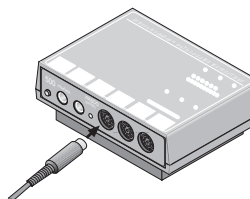

DataStudio	ScienceWorkshop (Mac)	ScienceWorkshop (Win)
M09 pH of Other Worlds.DS	M09 pH Samples	M09_PH.SWS

- Select ‘Open’ from the ‘File’ menu.
- Go to the Experiment Library. Find the document labeled as shown above. Double-click the document filename or select it and click OK or ‘Open’.
- The file opens with a Digits display and a Table display. Data recording is set for one measurement per second and will stop automatically at 30 seconds.
- The file opens with a Digits display and a Table display of pH. Data recording is set to stop automatically at 30 seconds.

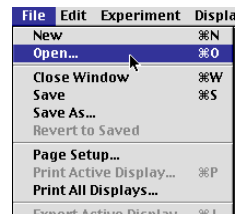

[] Calibrate the pH Sensor

1. Set up the equipment to calibrate the pH Sensor. To calibrate the pH Sensor you will need the following: wash bottle, distilled water, three beakers, buffer solutions of high pH (e.g. pH 10) and low pH (e.g. pH 4), pH Sensor.
2. Put 100 mL of the high pH buffer solution in one beaker. Put 100 mL of the low pH buffer solution into a second beaker. Put 100 mL of distilled water into the third beaker. Put distilled water into the wash bottle.



3. Connect the pH electrode to the BNC port on the pH Sensor.
 - Line up the connector on the end of the cable with the pin on the BNC port.
 - Push the connector onto the port and then twist the connector clockwise about one-quarter turn until it clicks into place.

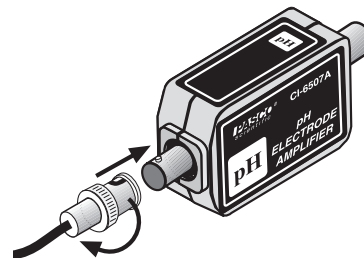

4. Remove the pH electrode from its bottle of buffer solution. Make sure the pH electrode is connected to the sensor.
5. Use the wash bottle to rinse the end of the electrode. Soak the pH electrode in the beaker of distilled water for 10 minutes.
6. In the Experiment Setup window, double-click the pH Sensor icon.

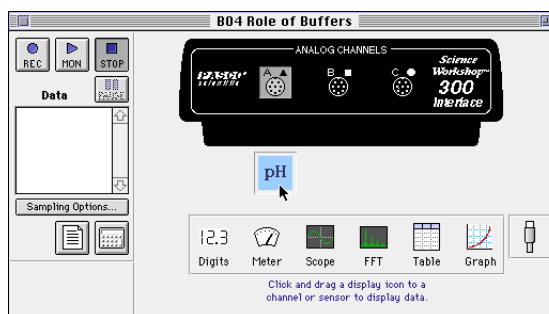
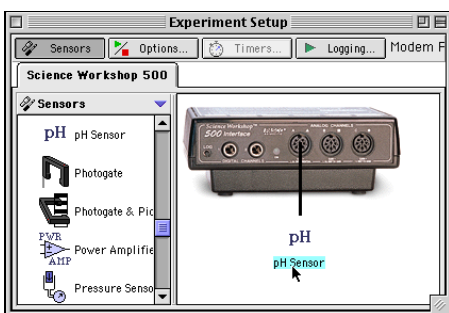

- In *DataStudio*, the Sensor Properties window will open. Click the 'Calibration' tab. In *ScienceWorkshop*, the Sensor Setup window opens.

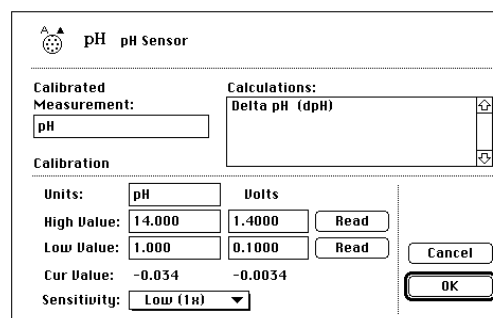
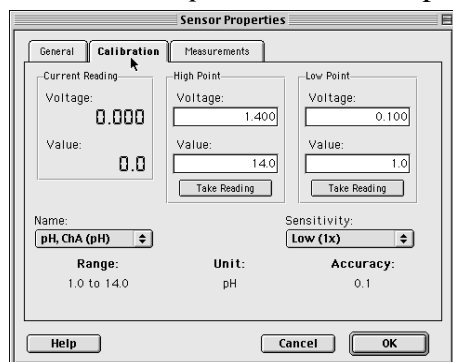

7. Calibrate with the high pH buffer solution. Put the end of the pH electrode into the high pH buffer solution.

8. Check the voltage under 'Current Reading' in *DataStudio* or next to 'Cur Value:' in *ScienceWorkshop*.
9. When the voltage stabilizes, click the 'Take Reading' button under 'High Point' in *DataStudio* or the 'Read' button in the row for 'High Value:' in *ScienceWorkshop*.
10. Enter the pH value of the buffer solution.
11. Thoroughly rinse the pH electrode with distilled water and dry it with a tissue.
12. Calibrate with the low pH buffer solution. Put the end of the pH electrode in the low pH buffer solution.
13. Check the voltage under 'Current Reading' in *DataStudio* or next to 'Cur Value:' in *ScienceWorkshop*. When the voltage stabilizes, click the 'Take Reading' button under 'Low Point' in *DataStudio* or the 'Read' button in the row for 'Low Value:' in *ScienceWorkshop*.
14. Enter the pH value of the buffer solution. Click OK to return to the Experiment Setup window.
15. Thoroughly rinse the pH electrode with distilled water and dry gently.

[] C. Do the Experiment

1. Click 'Start' in *DataStudio* or 'REC' in *ScienceWorkshop* to begin recording data.
 - The Digits display shows the pH value for the first chemical.
2. After data recording stops, remove the pH Electrode from the sample. Hold the pH Electrode over an empty beaker. Use the wash bottle with distilled water to thoroughly rinse off the pH Electrode.

• Dispose of the first substance as instructed.

• In general, it will be safe to dispose of these substances by pouring them down the sink with lots of water.

3. Repeat the process.

[] D. Analyze the Data

1. Use the Table display to examine the pH value of each substance. Determine whether each substance is acid, base, or neutral.

• Remember, a substance with a low pH value is an acid. A substance with a high pH value is a base. A substance with a pH value close to 7 is neutral.

2. Record your conclusions and answer the questions in the Report.

Technical Manual – Activity M10: Test for Life — Measure a Chemical Reaction

This part of the Technical Manual (Appendix B) gives information about how to use a Pressure Sensor and the Table and Graph displays to determine whether an unknown soil sample is likely to contain organic material that has the catalase enzyme.



NOTE: See the Technical Manual for Activity M06 - Design Landing Bags for information about the sensor.

[] A. Set Up the Equipment

- The glycerin lubricates the tubing so it can slip onto the barb end of the quick-release connector for the sensor and the other connector for the rubber stopper.
- When you add the mL of 3% hydrogen peroxide and the 75 mL of water to a 100 mL graduated cylinder, swirl the cylinder to mix the two liquids.
 - One team member could handle the rubber stopper while another team member handles the computer.
- Be ready to put the rubber stopper into the neck of the flask after you add the first soil sample to be tested.

[] B. Set Up the Experiment

- Connect the Pressure Sensor's DIN plug into Analog Channel A on the interface.
- Start *DataStudio* or *ScienceWorkshop* and open the file as follows:

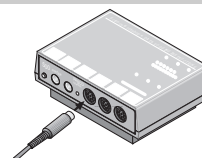

DataStudio	ScienceWorkshop (Mac)	ScienceWorkshop (Win)
M10 Test for Life.DS	M10 Test for Life	M10_LIFE.SWS

- Select 'Open' from the 'File' menu.
- Go to the Experiment Library. Find the document labeled as shown above. Double-click the document filename or select it and click OK or 'Open'.

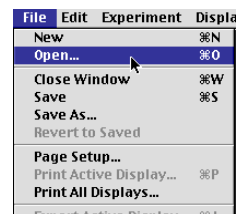

[] C. Do the Experiment

- Click 'Start' or 'REC' to begin recording data.
 - The Digits display will show normal atmospheric pressure, about 101 kilopascals.
- Add the first soil sample to the flask with the dilute hydrogen peroxide and quickly put the rubber stopper into the neck of the flask. Push the stopper in firmly.
- Swirl the flask to thoroughly mix the soil sample into the solution.
 - If this soil sample reacts with the hydrogen peroxide, the pressure should rise.
 - You may need to hold the stopper in place.
 - If the stopper pops off or comes loose so the gas inside escapes, that's okay. Just click the STOP button to stop recording data. Data recording stops automatically at 120 seconds.
- Be sure to remove the rubber stopper *slowly* to relieve any pressure. Empty the flask and rinse it with water. Dispose of the soil sample and hydrogen peroxide as instructed.
- Repeat the process for any other soil sample you have.

[] **D. Analyze the Data**

1. Examine the Table display and the Graph display. Determine whether either soil sample had organic material that contained the catalase enzyme.
 - The soil sample that had the greatest change in pressure *probably* contains organic material with the catalase enzyme.
 - Use the built-in statistics for either the Graph or the Table to find the minimum, maximum, and mean values of pressure. Use the minimum and maximum values to calculate the change in pressure.
2. Record your conclusions and answer the questions in the Report.

Data Logging — Installing Batteries

This part of Appendix C gives information about how to install batteries in the battery compartment of the *ScienceWorkshop 500* Interface.



Use four “AA” alkaline batteries.

If you are *replacing* batteries, use a small, flat-blade screwdriver.

Installing Batteries in the *Science Workshop 500* Interface

The *ScienceWorkshop 500* Interface uses four AA alkaline batteries. The battery compartment is on the *bottom* of the interface box.

To install the batteries, follow this procedure:

1. Place the interface box top down on a smooth horizontal surface so you can open the battery compartment.

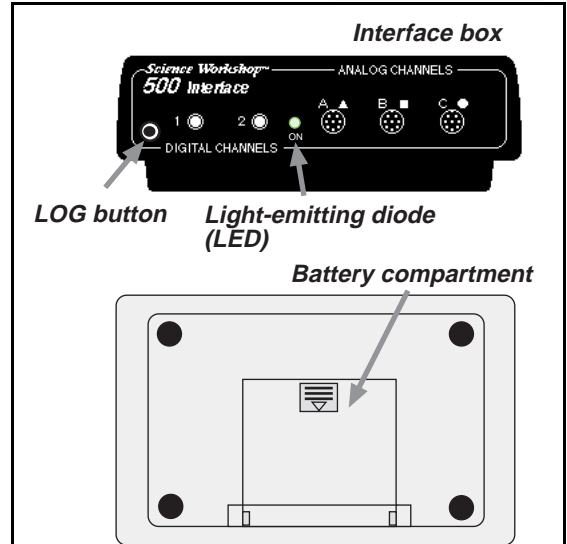

2. Put your thumb on the small striped rectangle at the edge of the battery compartment lid. Apply gentle pressure downward with your thumb and slide the battery compartment lid toward the back of the interface.

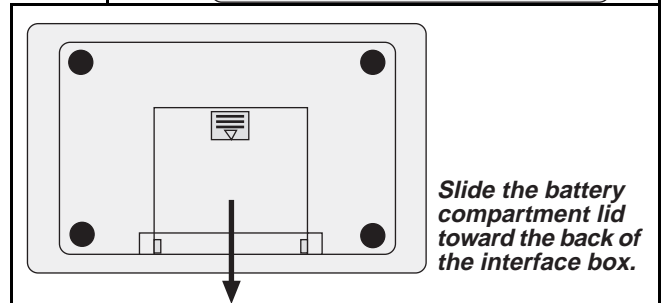

- The battery compartment has “plus” and “minus” signs next to small metal clips on either side of the compartment. These signs show which way each battery must be put into the compartment.

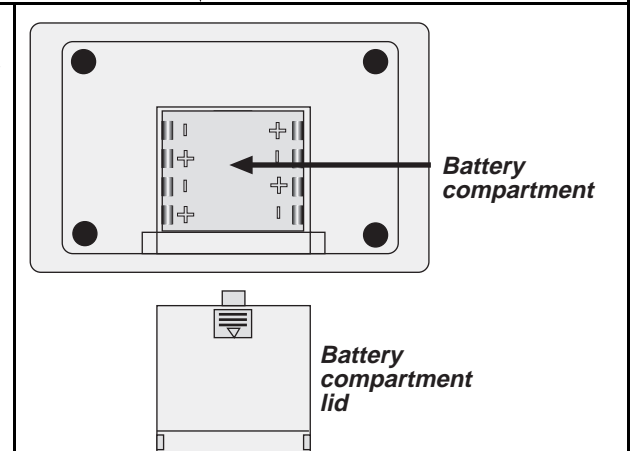

3. Install the batteries one at a time. Be sure each battery is in place and makes good contact with the small metal clips at each end.

NOTE: The batteries fit into the compartment tightly.

4. Line up the battery compartment lid with the edges of the battery compartment and slide the lid back over the compartment. The small piece of plastic at the front edge of the lid should snap into place.

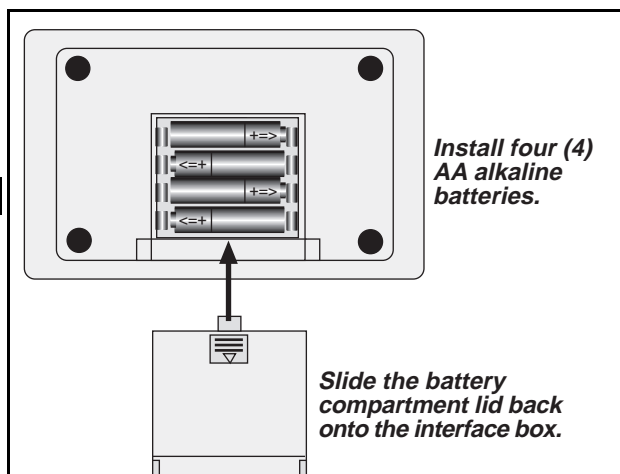

Check the batteries by sliding the power switch on the back panel to ON. The light-emitting diode (LED) on the front panel should light up. If not, open the battery compartment and re-install the batteries.

Replacing Batteries

5. To *replace* batteries, remove the battery compartment lid. Use a small, flat-blade screwdriver as a lever to pry out the old batteries one-at-a-time. Put in new batteries as described above.

Data Logging — Disconnect for Logging

This part of Appendix C gives information about how to disconnect the *ScienceWorkshop 500* Interface for data logging.



Disconnect for Data Logging

There are a few simple steps to follow after you set up your experiment and you are ready to disconnect the interface.

- Before you disconnect the interface, save your experiment file using **Save** or **Save As...** from the **File** menu.

1. Prepare the *ScienceWorkshop* interface for data logging.
 - Make sure that there are four AA alkaline batteries in the interface battery compartment.
 - Make sure that the POWER switch on the back panel of the interface is ON.

2. Set up the software for data logging.
 - In *DataStudio*, click the 'Experiment' menu in the menu bar and select 'Disconnect for Logging' or click 'Logging' () in the Setup window toolbar.

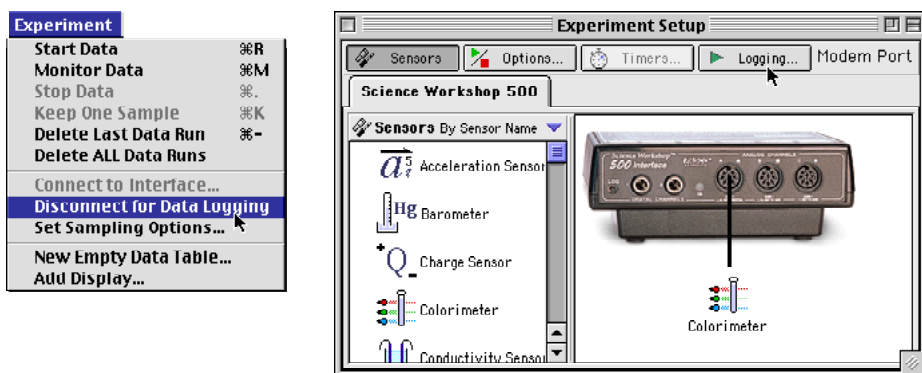

- **Result:** In *DataStudio*, a window opens reminding you that you can print an experiment summary if you want. (If your computer is connected to a printer you can print an experiment summary.)

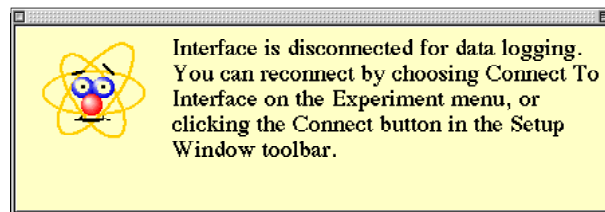
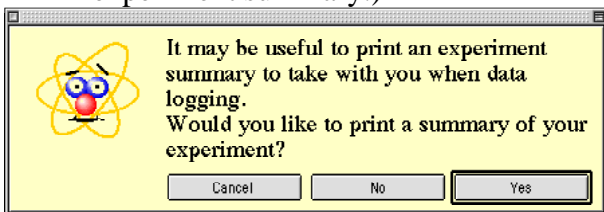

- After you click 'Yes' or 'No', the *DataStudio* software is ready for data logging.

- In *ScienceWorkshop*, click the 'Experiment' menu and select 'Disconnect for Logging...'.
Result: The Data Logging Setup window opens. (If your computer is connected to a printer you can print a checklist.) Click 'Begin Logging' when you are ready to begin data logging.

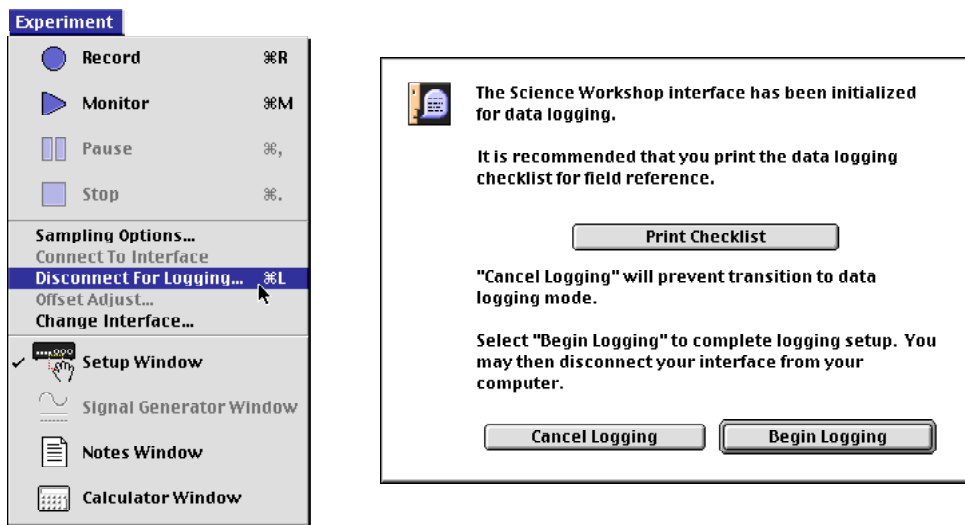

- The interface goes into "sleep" mode. The green light-emitting diode (LED) on the front panel of the interface will go out, and then will blink once every five seconds.

- Disconnect the interface from the computer. Unplug the power cord and the interface cable from the back of the interface box. (It doesn't matter which is unplugged first).

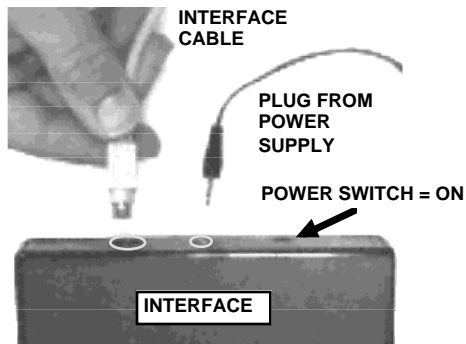

- Carry the interface and equipment to the experiment site.

Data Logging — Data Recording

This part of Appendix C gives information about data recording with the *ScienceWorkshop 500* Interface when the interface is disconnected from the computer.



Data Recording with the *ScienceWorkshop 500* Interface

The *ScienceWorkshop 500* Interface has several key features that are important for data logging:

- battery operation makes the interface portable
- 'sleep' mode lengthens battery life
- front panel LOG button starts and stops remote data measurement
- light-emitting diode (LED) blinks to show which 'mode' the interface is in (sleep, wake up, or record)

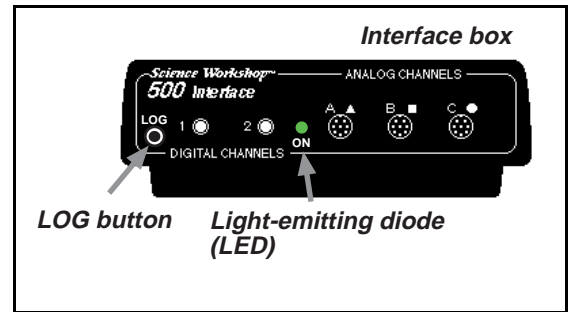

SAFETY REMINDERS : *Do not use the interface in conditions that might harm the interface.*

- Do not put the interface into water or other liquids
- Do not put the interface into conditions of extreme temperatures or intense heat or cold
- Do not put the interface into a vacuum
- Do not put the interface into electric appliances such as a microwave or toaster oven

Overview

Set up an experiment as you normally would using the *DataStudio* or *ScienceWorkshop* program.

Disconnect the interface from the computer and record data with the interface. (*See the previous section.*)

- Leave the power switch ON. The front panel LED blinks once every five seconds while the interface is in 'sleep' mode and blinks rapidly while the interface is recording data.

After you collect data, re-connect the interface to the computer to display and analyze the data. (*See the next section.*)

1. Set up the experiment while connected to the computer.

2. Disconnect the interface and go collect data.

3. Re-connect the interface and download the data for analysis.

Go to the location where you want to make your measurements. Set up the interface, sensors, equipment, etc., as needed for the activity.

Record Data

- The front panel LED blinks once every five seconds while the interface is in ‘sleep’ mode.
1. Press the LOG button on the lower left corner of the front panel to “wake up” the interface.
- The interface takes ten seconds to wake up. The LED blinks once each second for ten seconds. The ten second delay gives you time to get ready to record data.
 - When the interface is fully “awake”, the LED will begin blinking rapidly (several blinks each second).

NOTE: Data recording begins when the LED begins blinking rapidly.

2. While the LED is blinking rapidly, do the experiment or activity that you wish to record.
- The interface records data and stores it in its recording buffer. Data recording continues until you press the LOG button to stop or the recording buffer is filled with data. When you stop data logging, the interface returns to the power-saving “sleep” mode.
3. Press the LOG button again to stop data recording.
- The LED will blink once every five seconds when the interface is in “sleep” mode.

Record More Data

To record another run of data, follow the same steps:

1. Press the LOG button to “wake up” the interface.
2. Collect data while the LED is blinking rapidly.
3. Press and LOG button again to stop data recording and put the interface back into “sleep” mode.

Full Recording Buffer

When the interface’s data buffer is full, the interface will go into the “sleep” mode automatically (the LED will blink once per five seconds). If you try to record more data and press the LOG button, the LED will not begin to blink rapidly. Instead it will slowly brighten and fade three times. The interface will go back to the “sleep” mode (LED blinks once per five seconds).

- You can empty the recording buffer so you can record more data, or...
- You can re-connect the interface to the computer and download your data into the computer.

Follow this procedure to empty the data buffer: **NOTE: ALL of your data will be cleared!**

1. Press and hold the LOG button for approximately 5 seconds. The LED will turn ON and remain ON to show that the recording buffer is empty.
2. Release the LOG button to put the interface back into “sleep” mode.

Data Logging Mode Summary	LED description
sleep	blinks once every five seconds
wake up	blinks once per second for ten seconds
data recording	blinks rapidly
recording buffer is full	slowly brighten and fade three times

Data Logging — Reconnect to Download and Analyze Data

This part of Appendix C gives information about reconnecting the *ScienceWorkshop 500* Interface to the computer and downloading the data that you recorded.

Reconnect for Data Download

After you have recorded your data, reconnect the interface to the computer.

- Plug the interface cable into the back panel of the interface box.
- Plug the power supply into the power outlet.
- It doesn't matter which you plug in first.
- Remember to leave the power switch ON.
- The interface is still in 'sleep' mode, so the LED blinks once every five seconds.

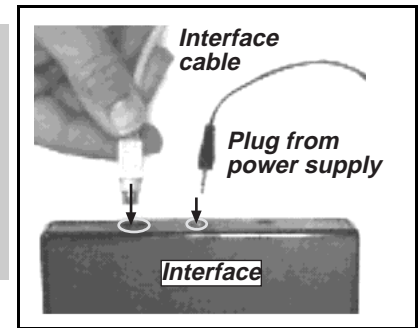
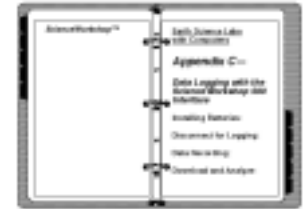

1. If the software is already running, select 'Connect to Interface' from the 'Experiment' menu menu. NOTE: In *DataStudio*, you can use the menu OR click the 'Connect' button in the Setup window toolbar.

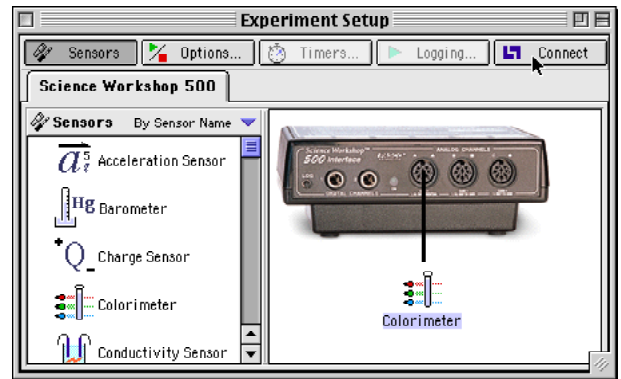
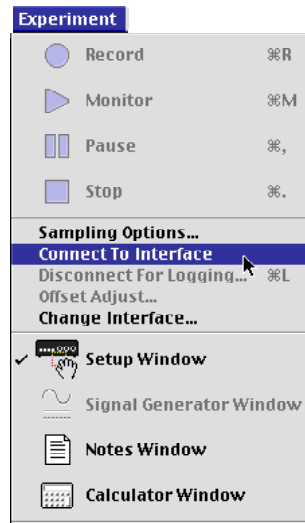
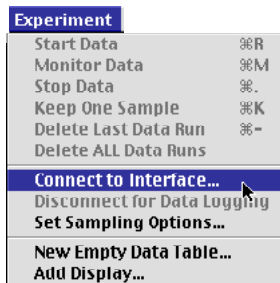

- **Result #1:** The program will send a “wake up” message to the interface and then the program will automatically retrieve the data stored in the interface recording buffer.
 - **Result #2:** The LED will light up and stay ON.
 - **Result #3:** The run(s) of data you collected will appear in the Data list.
2. If the software is not running, start the program. The program will automatically “wake up” the interface and retrieve your data.
 - Your run(s) of data will appear in the Data list in the Experiment Setup window and the LED on the interface will light up and stay ON.

